

Knob Operating Type Potentiometer Without Knob Type

RK08H Series



Compact type potentiometer suitable for volume and tone controls.

Rotary
Potentiometers

Slide
Potentiometers

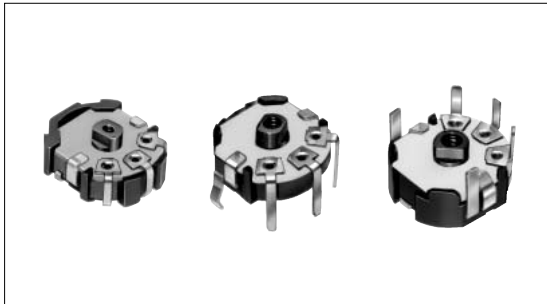

Typical Specifications

Items	Specifications
Total resistance tolerance	± 30%
Maximum operating voltage	50V AC 20V DC (Single-unit only)
Total rotational angle	200 ± 10 °
Operating life	Without detent 10,000cycles With detent 5,000cycles
Operating temperature range	- 10 to + 60

Metal
Shaft

Insulated
Shaft

Knob
Operating

Product Line

Number of resistor elements	Mounting direction	Length of the shaft (mm)	Center detent	Total resistance (k)	Resistance taper	Soldering	Minimum order unit (pcs.)	Products No.	Drawing No.
Single-unit	Vertical type	1	Without	50	1B	Manual	100	RK08H11100U3	1
				10				RK08H11100UD	
			100	RK08H11100XC					
	4.5	With	10	15A	RK08H1110A04				
			10		RK08H11100X7			2	
		Back-to-back mounting type	50	15C	RK08H1120030			3	
Dual-unit	Vertical type	1	Without	10	1B	Reflow	1,000	RK08H113003Q	4
				50				RK08H113003G	
				10	15A			Manual	100
	50		15C	RK08H12100F3					
	10		15A	RK08H122005A	3				
	Back-to-back mounting type		50	15C	Reflow	1,000	RK08H123002K	4	
Vertical type	50	15C	Reflow	1,000	RK08H123002K	4			



Notes

1. Products other than those listed in above products are also available. Please contact us for details.
2. Dip soldering can be applied to the above products. For dip soldering applications, specify separately as "dip soldering applicable product." Back-to-back mounting types are excluded.
3. We recommend print boards with a thickness of 0.8mm to 1.2mm. For 1.6mm thickness board applications, please contact us.

Refer to P.393 for product varieties.
Refer to P.393, 502 for resistance taper.

Dimensions(Vertical Type)

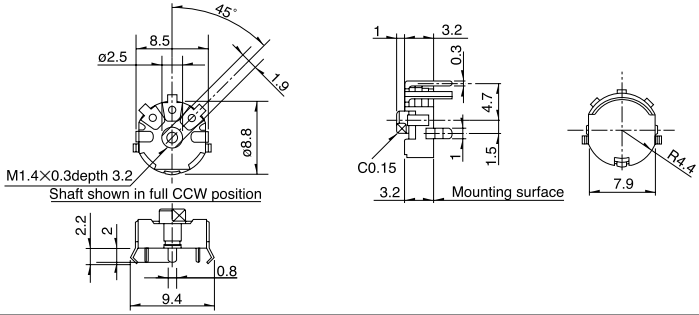
Unit:mm

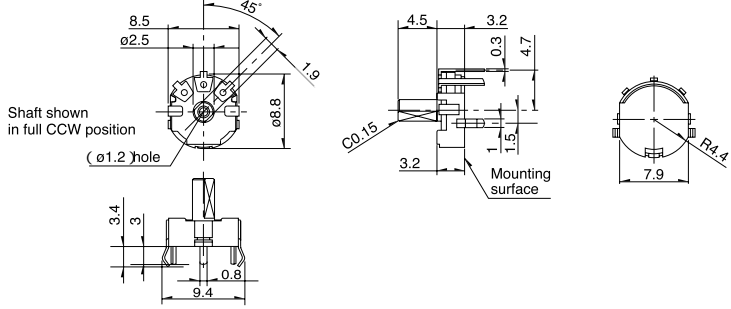
No.	Photo	Style
1	<p>Single-shaft, single-unit RK08H1110 Single-shaft, dual-unit RK08H1210</p> 	
2	<p>Single-shaft, single-unit RK08H1110</p> 	

PC Board Mounting Hole Details

Unit:mm

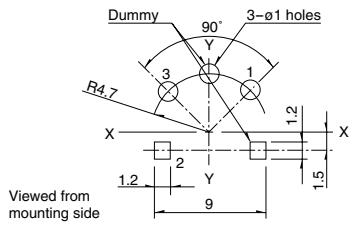
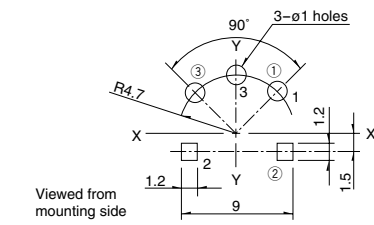
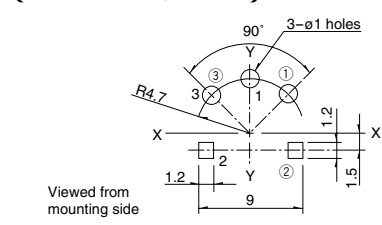
<p>Single-shaft, single-unit</p> 	<p>Single-shaft, dual-unit</p> 	<p>Single-shaft, dual-unit (Resistance taper 15 C)</p> 
--	--	--

Dimensions(Back-to-back Mounting Type)

Unit:mm

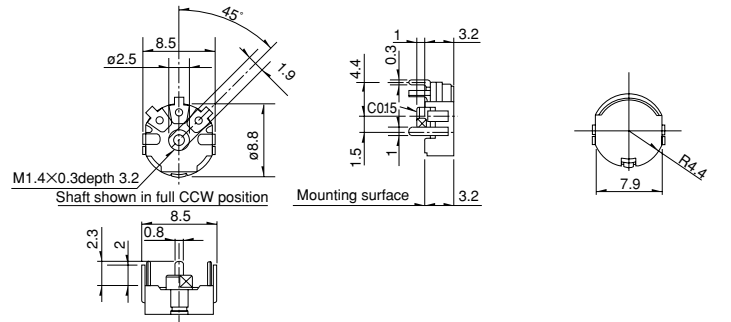
No.	Photo	Style
3	<p>Single-shaft, single-unit RK08H1120 Single-shaft, dual-unit RK08H1220</p> 	

PC Board Mounting Hole Details

Unit:mm

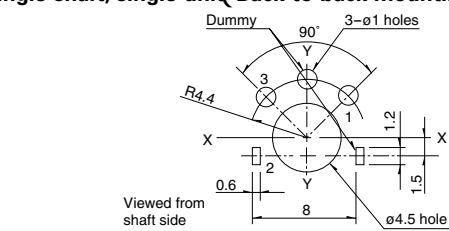
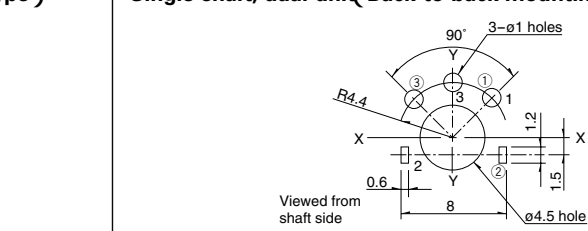
<p>Single-shaft, single-unit(Back-to-back mounting type)</p> 	<p>Single-shaft, dual-unit(Back-to-back mounting type)</p> 
--	---

Note

Keep the DUMMY terminal open in the circuit.

Dimensions(Reflow Type)

Unit:mm

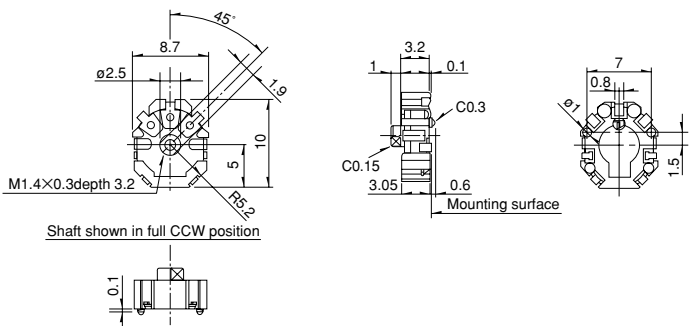
No.	Photo	Style
4	<p>Single-shaft, single-unit RK08H1130 Single-shaft, dual-unit RK08H1230</p> 	 <p>M1.4×0.3depth 3.2 Shaft shown in full CCW position</p>

PC Board Mounting Hole Details

Unit:mm

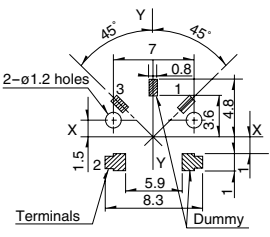
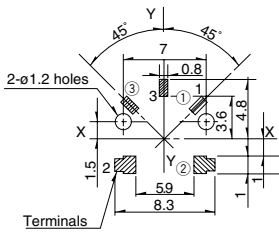
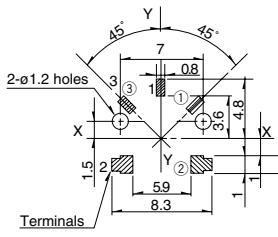
Single-shaft, single-unit	Single-shaft, dual-unit	Single-shaft, dual-unit (Resistance taper 15 C)
		

Standard Specification Circuit Diagram

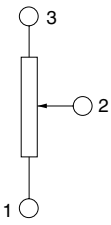
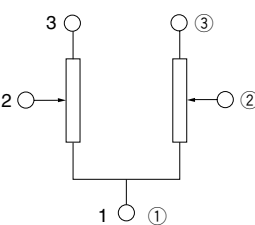
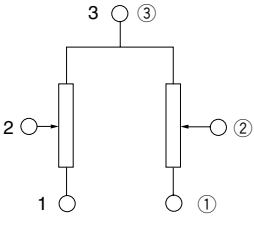
Single-shaft, single-unit	Single-shaft, dual-unit	Single-shaft, dual-unit (Resistance taper 15 C)
		

Note

Keep the DUMMY terminal open in the circuit.

Product Varieties

When ordering product varieties that are not listed in the Product Line, please specify by referring to the below example.

Total Resistance Variety

Total resistance(k)	5	10	20	50	100
----------------------	---	----	----	----	-----

Resistance Taper

Resistance taper	15A	1B	3B	15C
------------------	-----	----	----	-----

Rotary Potentiometers
Slide Potentiometers

Orders Other Than Recommended Products

When ordering product varieties that are not listed in the Product Line, please specify by referring to the below example.

Sample Part Number

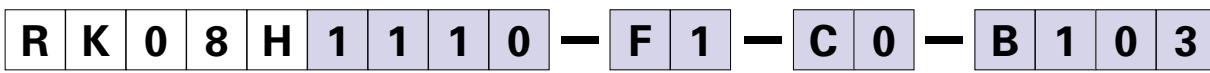

Model type

Code	Model type
111	Single-unit Vertical type
112	Single-unit Back-to-back mounting type
113	Single-unit Reflow type
121	Dual-unit Vertical type
122	Dual-unit Back-to-back mounting type
123	Dual-unit Reflow type

Length of the shaft(mm)

Code	Length of the shaft
F1	1
F4	4.5

* Only 1mm types are provided with the M1.4 tap screws.
* Reflow soldering cannot be applied in the 4.5 mm type.

Detent

Code	Center detent
C0	Without
C1	With

* Detent can only be specified for non-reflow single-unit types.

Resistance taper

Code	Resistance taper	Code	Resistance taper
A	15A	C	15C
B	1B	V	3B

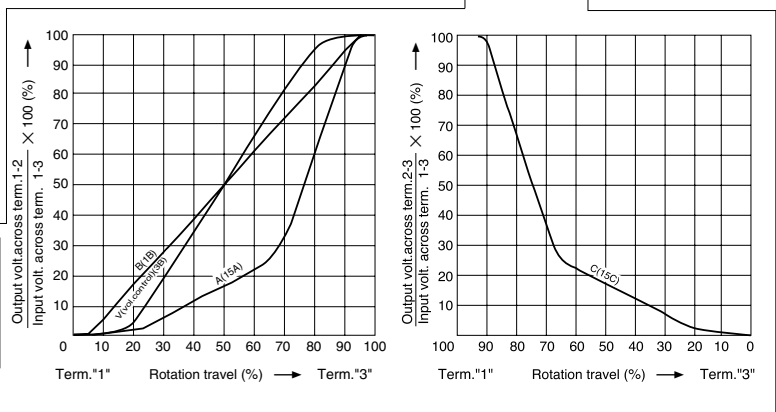

Total resistance

Code	Total resistance (kΩ)	Code	Total resistance (kΩ)
502	5	503	50
103	10	104	100
203	20		

Note

marked are specifications recommended by ALPS.

Metal Shaft
Insulated Shaft
Knob Operating

List of Varieties

Items	Type		Without knob		With knob			
	Model		RK08H1 1 RK08H1 2	RK08H1 3	RK10J1 E	RK10J1 R	RK14J1 A	RK14J1 R
			Vertical back-to-back mounting	Reflow type	Insertion type	Reflow type	Insertion type	Reflow type
Photo								
Electrical performance	Rated power		0.03W					
	Insulation resistance		100M min. 100V DC					
	Voltage proof		100V AC (for 1minute)					
Mechanical performance	Strength of the operating section	Stopper strength	0.1N·m		70mN·m			
		Push-pull strength (In vertical direction against the P.W.B. surface)	10N max.		5N max.			
	Vibration		10 to 55 to 10Hz/min., the amplitude is 1.5mm for all the frequencies, in the 3 direction of X, Y and Z and for 2 hours respectively					
	Solder heat resistance	Manual soldering	350 max. 3s max.					
		Dip soldering	—				260 ± 5 4 ± 1s	—
Reflow soldering		—	Please see P.398	—	Please see P.398	—	Please see P.398	
Environmental performance	Cold		- 10 ± 2 for 96h			- 25 ± 2 for 240h		
	Dry heat		70 ± 2 for 96h			70 ± 2 for 240h		
	Damp heat		40 ± 2 , 90 to 95%RH for 96h					
Page			390		394			

Rotary Potentiometers
Slide Potentiometers

Metal Shaft

Insulated Shaft

Knob Operating

Maximum Attenuation or Residual Resistance

Application of non-standard

Nominal total resistance	Maximum attenuation	Nominal total resistance	Residual resistance
R 100k	90dB min.	100k R 50k	0.1% or less of nominal total resistance
100k > R 50k	80dB min.	50k > R > 10k	30 or less
50k > R 10k	70dB min.	10k R	20 or less
10k > R	60dB min.		

Knob Operating Type Potentiometers Cautions399

Knob Operating Type Potentiometers Soldering Conditions398

Note

Contact us separately when you require reflow type taping specifications.

Soldering Conditions

Soldering Conditions

1. Recommended reflow conditions

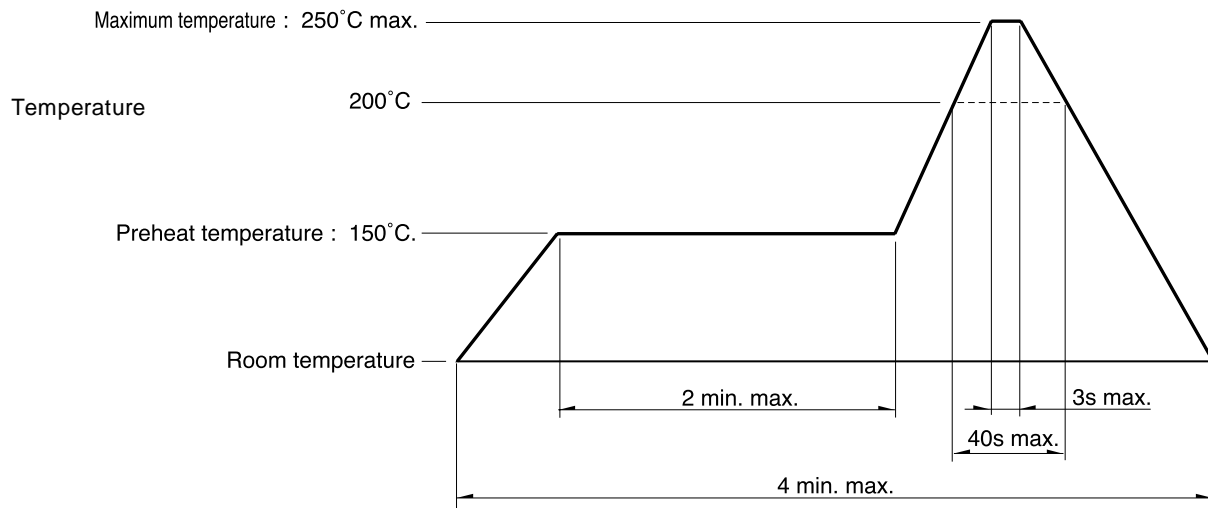

- | | |
|------------------------------|--|
| 2. Cleaning | Cleaning should not be attempted. |
| 3. Type of solder to be used | Use cream solder that contains 10 - 15 %wt flux. |
| 4. Soldering | Mounting plate should also be soldered. |

Notes

- When using an infrared reflow oven, solder may sometimes not be applied. Be sure to use a hot air reflow oven or a type that uses infrared rays in combination with hot air.
- The temperatures given above are the maximum temperatures at the terminals of the potentiometer when employing a hot air reflow method. The temperature of the PC board and the surface temperature of the potentiometer may vary greatly depending on the PC board material, its size and thickness. Ensure that the surface temperature of the potentiometer does not rise to 250°C or greater.
- Conditions vary to some extent depending on the type of reflow bath used. Be sure to give due consideration to this prior to use.

Rotary Potentiometers
Slide Potentiometers

Metal Shaft

Insulated Shaft

Knob Operating