

Specifications

Insulation Resistance: 1,000MΩ min. at 500V DC
 Dielectric Withstanding Voltage: 700V AC for 1 minute
 Contact Resistance: 30mΩ max. at 10mA/20mV max.
 Operating Temperature Range: -55°C to +170°C
 Mating Cycles: 10,000 insertions min.
 Pin Count: 144 contact pins

Materials and Finish

Housing: Polyetherimide (PEI), glass-filled
 Contacts: Beryllium Copper (BeCu)
 Plating: Gold over Nickel

Features

- Card thickness 1.00mm
- 4 different positioning indicators

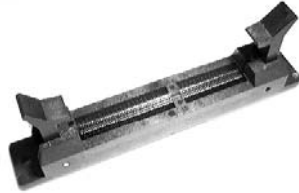

Part Number (Details)

IC-497 - 1 - * - MF

Series No.

Design No.

Positioning Detail (see Section "A")

MF = Flanged
 Unmarked = Not Flanged

Outline Socket Dimensions

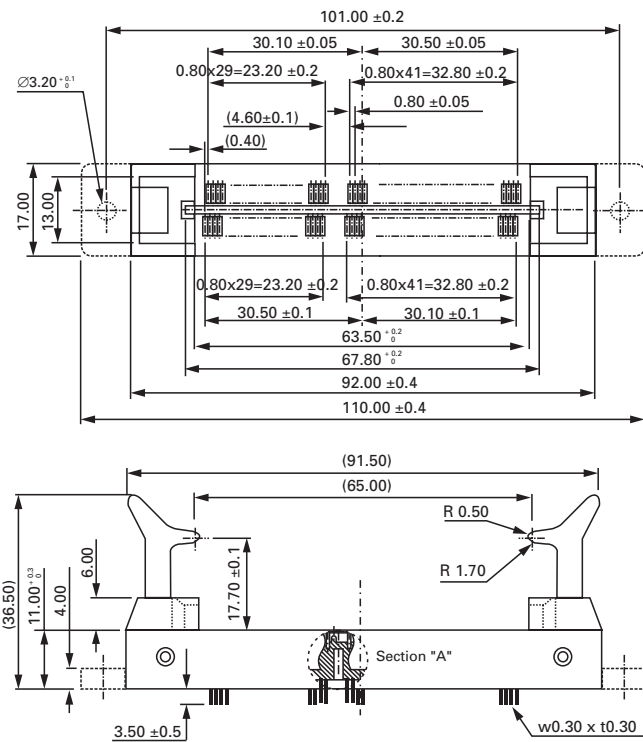

Recommended PC Board Layout

Top View from Socket

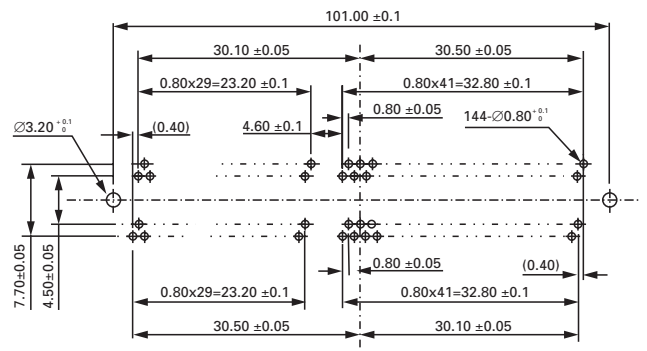

Positioning Details

Section "A"

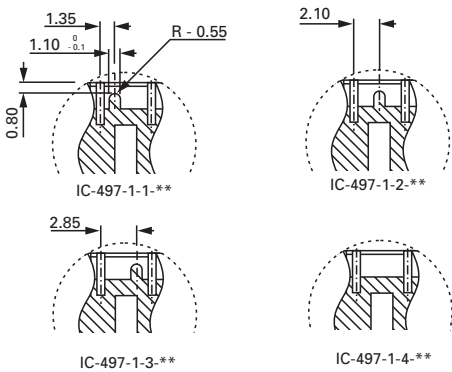

Matching Module Dimensions

