

**SS-12D10-G050**

G-Switch P/N

直柄

- G=020(2.0) G=030(3.0)
- G=040(4.0) G=050(5.0)
- G=055(5.5) G=060(6.0)
- G=065(6.5) G=070(7.0)
- G=075(7.5) G=080(8.0)
- G=085(8.5) G=090(9.0)
- G=095(9.5) G=100(10.0)

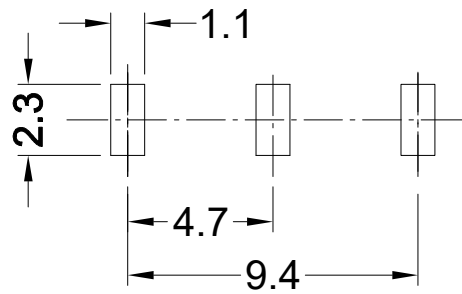
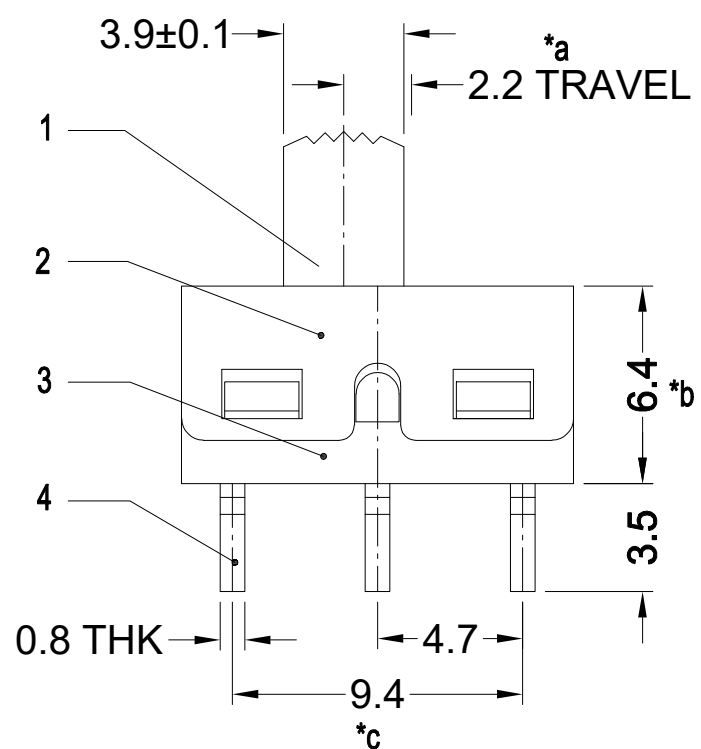

**P.C.B LAYOUT  
TOP VIEW**

Electrical  
 ELECTRICAL SPECIFICATIONS: 3.0A/DC24V  
 CONTACT RESISTANCE (CR): ≤50MΩ  
 INSULATION RESISTANCE(IR): ≥100MΩ DC250V  
 COMPRESSIVE STRENGTH (WV): AC250V 1MINUTE  
 STORAGE HUMIDITY: <85%RH  
 OPERATING TEMPERATURE: -40°C to 80°C

7	STEEL BALL	STEEL	1	NATURAL
6	SPRING	STEEL WIRE	1	NATURAL
5	CONTACT	BRASS STRIP	1	Ag PLATED
4	TERMINAL	BRASS STRIP	3	Ag PLATED
3	CASE	PA66	1	BLACK
2	COVER	SUS	1	NATURAL
1	KNOB	PA66	1	BLACK
NO.	PARTS	MATERIALS	Q'TY	FINISH



**G-Switch Electronic (HongKong) CO.,Ltd.**

Unless otherwise specified, Tolerance:  
 X. ±0.30  
 X.x ±0.20  
 X.xx ±0.15  
 X.xxx ±0.10  
 Angles ±3°

DESIGN Li Qingqi DATE 2022.07.05  
 CHECKED DATE  
 APPROVED DATE  
<http://www.dg-switch.com>  
 TEL:0769-82388879

Molde code:  
 SS-12D10-G050  
 REV.: X1 SCALE: 4:1 UNIT: mm  
 SIZE: A4 SHEET: 1/1

