

# Analog Displacement Sensor for Mounting in Hydraulic Cylinder



This sensor is designed to be integrated into a hydraulic cylinder. Due to its small diameter, it can be fitted in the rod of small cylinders. The geometry of the profile and wiper is perfectly suited to operation at an optimum speed under all oil viscosity conditions encountered in the temperature range.

## FEATURES

- Conductive plastic potentiometer technology. Infinite resolution
- Precious metal multi-contact wiper
- Light alloy profiled support
- Wire or connector outputs
- Material categorization: for definitions of compliance please see [www.vishay.com/doc?99912](http://www.vishay.com/doc?99912)



## QUICK REFERENCE DATA

Sensor type	LINEAR, conductive plastic
Output type	Wires and connector
Market appliance	Industrial
Dimensions	Diameter 12 mm

## ELECTRICAL SPECIFICATIONS

PARAMETER	
Theoretical electrical travel (TET)	100 mm to 1000 mm
Independent linearity standard	± 0.1 %
Independent linearity optional	± 0.05 %
Total resistance ( $R_n$ )	425 $\Omega$ /cm (350 $\Omega$ /cm to 4000 $\Omega$ /cm optional)
Tolerance on $R_n$	± 20 %
Temperature coefficient	-300 ± 300 ppm/°C
Power rating at +25 °C	0.3 W/cm of travel
Power rating at +125 °C	0 W/cm
Wiper current	≤ 1 mA
Recommended load impedance	≥ 1000 $R_n$
Dielectric strength	1000 $V_{RMS}$ , 50 Hz, 1 min
Insulation resistance	≥ 10 $G\Omega$ at 500 $V_{CC}$
Output smoothness	≤ 0.05 %

## MECHANICAL SPECIFICATIONS

PARAMETER	
Mechanical travel	TET + 1.5 mm
Driving force	≤ 1 N typical
Backlash	< 10 $\mu$ m
Maximum displacement speed	1.5 m/s (32 cst oil)

## PERFORMANCE

PARAMETER	
Operating temperature range	-40 °C to +125 °C
Storage temperature range	-55 °C to +125 °C
Life	20M cycles for TET ≤ 300 mm 10M cycles for 300 mm < TET ≤ 600 mm 5M cycles for TET > 600 mm
Operating pressure	350 bar in continuous mode (600 bar at peak)

### Note

- Nothing stated herein shall be construed as a guarantee of quality or durability.

SAP PART NUMBERING GUIDELINES					
MODEL	DIAMETER	LENGTH (mm)	VALUE	LINEARITY	PACKAGING
PRHY	12	107	9631 = 9K6	D = 0.1 %	B = box
		177	1592 = 15K9		
		527	4742 = 47K4		

**CONNECTIONS**

**Design 1:** Standard version with connector inserted in interface flange  
**Design 2:** Sensor with wire outputs without sealed feed-through and flange  
**Design 3:** Sensor equipped with a sealed feed-through and a wire output cylinder interface flange

**DIMENSIONS** in millimeters

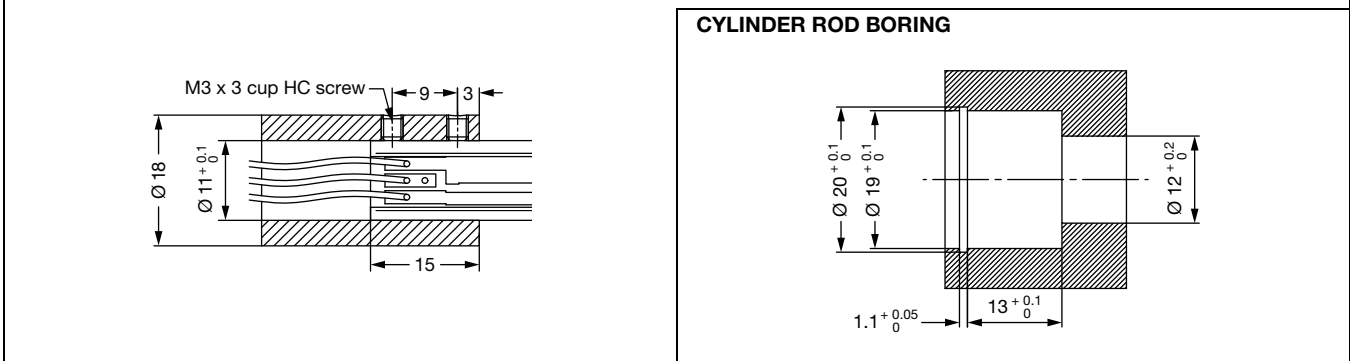
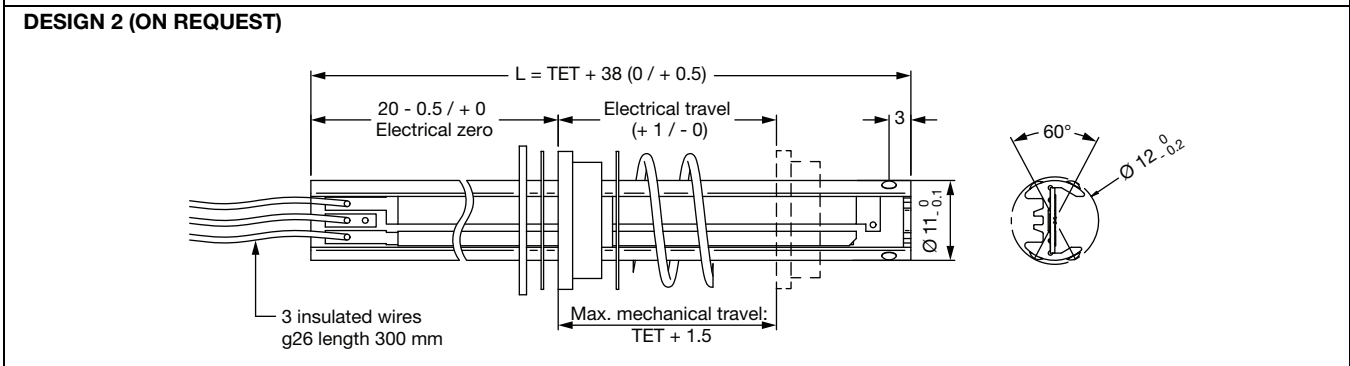
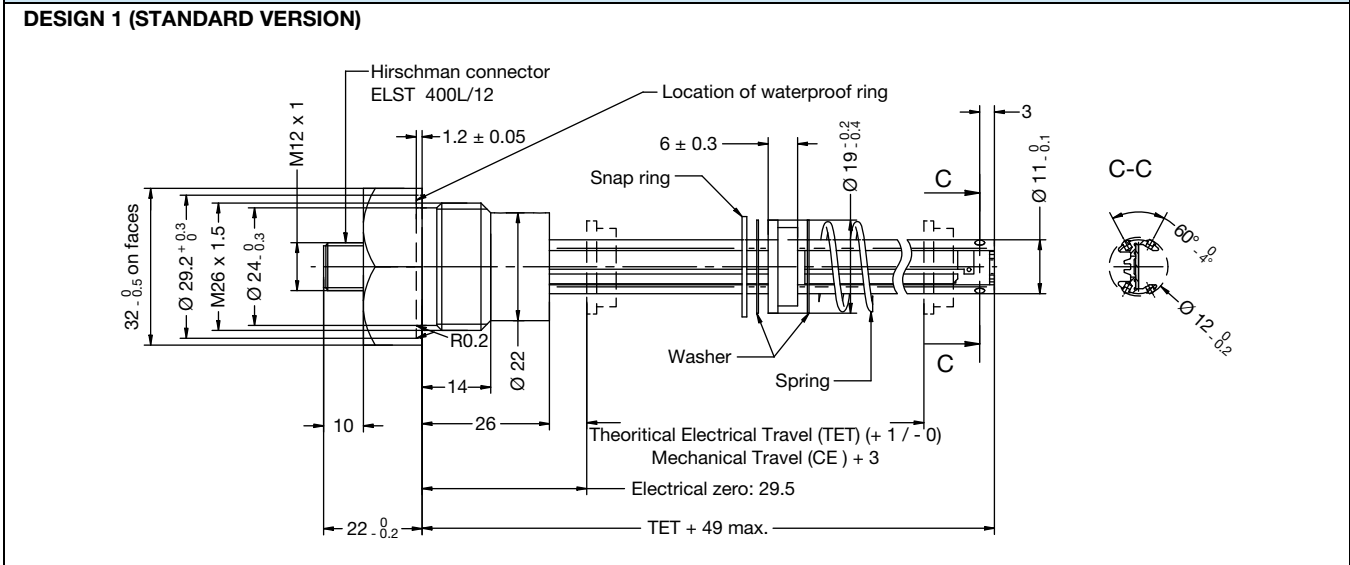

**DIMENSIONS** in millimeters

**DESIGN 3 (ON REQUEST)**



**ELECTRICAL DIAGRAM**

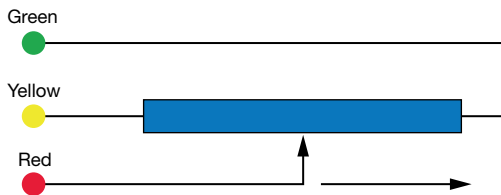

**OPTIONS** (on request)

- Other ohm value ( $R_n$ ) - see Electrical Specifications
- Other linearity - see Electrical Specifications
- Special equipment
- Other diameter: 6 mm



## **Disclaimer**

ALL PRODUCT, PRODUCT SPECIFICATIONS AND DATA ARE SUBJECT TO CHANGE WITHOUT NOTICE TO IMPROVE RELIABILITY, FUNCTION OR DESIGN OR OTHERWISE.

Vishay Intertechnology, Inc., its affiliates, agents, and employees, and all persons acting on its or their behalf (collectively, "Vishay"), disclaim any and all liability for any errors, inaccuracies or incompleteness contained in any datasheet or in any other disclosure relating to any product.

Vishay makes no warranty, representation or guarantee regarding the suitability of the products for any particular purpose or the continuing production of any product. To the maximum extent permitted by applicable law, Vishay disclaims (i) any and all liability arising out of the application or use of any product, (ii) any and all liability, including without limitation special, consequential or incidental damages, and (iii) any and all implied warranties, including warranties of fitness for particular purpose, non-infringement and merchantability.

Statements regarding the suitability of products for certain types of applications are based on Vishay's knowledge of typical requirements that are often placed on Vishay products in generic applications. Such statements are not binding statements about the suitability of products for a particular application. It is the customer's responsibility to validate that a particular product with the properties described in the product specification is suitable for use in a particular application. Parameters provided in datasheets and / or specifications may vary in different applications and performance may vary over time. All operating parameters, including typical parameters, must be validated for each customer application by the customer's technical experts. Product specifications do not expand or otherwise modify Vishay's terms and conditions of purchase, including but not limited to the warranty expressed therein.

Except as expressly indicated in writing, Vishay products are not designed for use in medical, life-saving, or life-sustaining applications or for any other application in which the failure of the Vishay product could result in personal injury or death. Customers using or selling Vishay products not expressly indicated for use in such applications do so at their own risk. Please contact authorized Vishay personnel to obtain written terms and conditions regarding products designed for such applications.

No license, express or implied, by estoppel or otherwise, to any intellectual property rights is granted by this document or by any conduct of Vishay. Product names and markings noted herein may be trademarks of their respective owners.