

AME8852

■ General Description

The AME8852 family of positive, CMOS linear regulators provide low dropout voltage (110mV@150mA), low quiescent current, and low noise CMOS LDO. These rugged devices have both Thermal Shutdown, and Current limit to prevent device failure under the "Worst" of operating conditions.

■ Features

- Low Dropout Voltage: 110mV@150mA
- Guaranteed Current: 150mA
- Quiescent Current: 60μA (typ.)
- Over-Temperature Shutdown
- Current Limiting Protection
- PSRR: 60dB@10KHz
- Ultra-Low-Noise: 100μV_{RMS} at 1Hz to 100KHz
- Low Temperature Coefficient
- Input Voltage Range: 2.5V~5.5V
- Output Voltage Range: 0.8V~4.3V
- Green Products Meet RoHS Standards

■ Applications

- Instrumentation
- Portable Electronics
- Wireless Devices
- Cordless Phones
- PC Peripherals
- Battery Powered Widgets

■ Typical Application

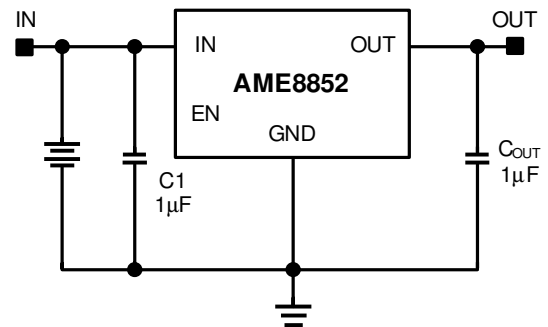

■ Functional Block Diagram

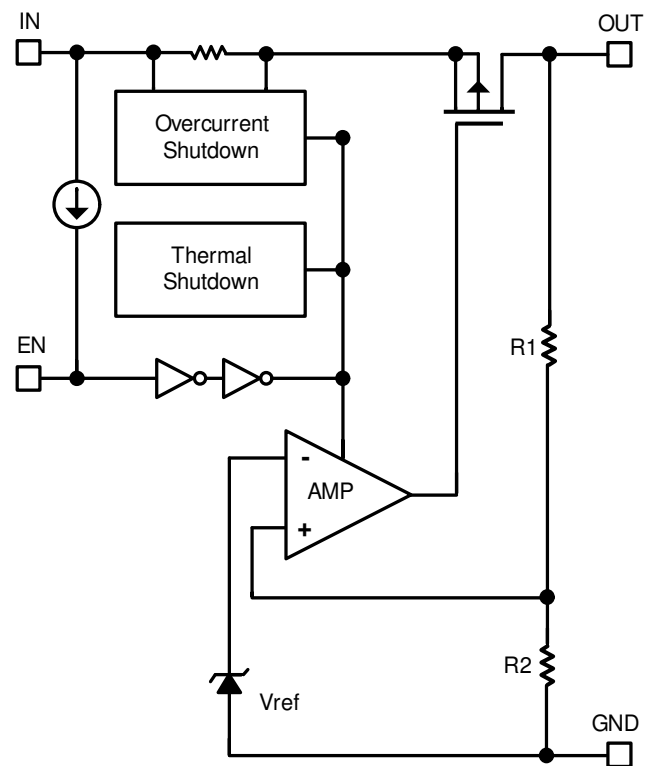

AME8852

■ Pin Configuration

SOT-23
Top View

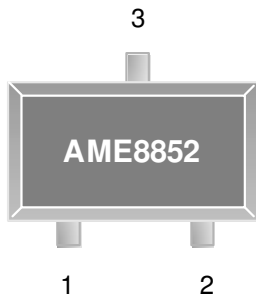

AME8852-AETxxx

1. GND
2. OUT
3. IN

*** Die Attach:
Non-Conductive Epoxy**

SC-70-4 (SC-82)
Top View

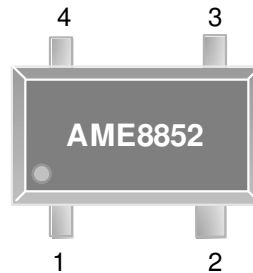

AME8852-AIUxxx

1. EN
2. GND
3. OUT
4. IN

*** Die Attach:
Conductive Epoxy**

SOT-25/TSOT-25A
Top View

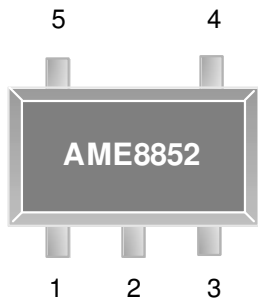

AME8852-AEVxxx

1. IN
2. GND
3. EN
4. NC
5. OUT

*** Die Attach:
Conductive Epoxy**

■ Pin Description

Pin Number			Pin Name	Pin Description
SOT-23	SC-70-4 (SC-82)	SOT-25 / TSOT-25A		
N/A	1	3	EN	Enable pin, Active "high". When pulled "low", the PMOS pass transistor turns off, current consuming less than 1 μ A. When EN pin floating outside, it is pulled High by internal small current source.
N/A	N/A	4	NC	No connection.
1	2	2	GND	Ground connection pin.
2	3	5	OUT	LDO voltage regulator output pin; should be decoupled with a 1 μ F or greater capacitor.
3	4	1	IN	Input voltage pin; should be decoupled with 1 μ F or greater capacitor.

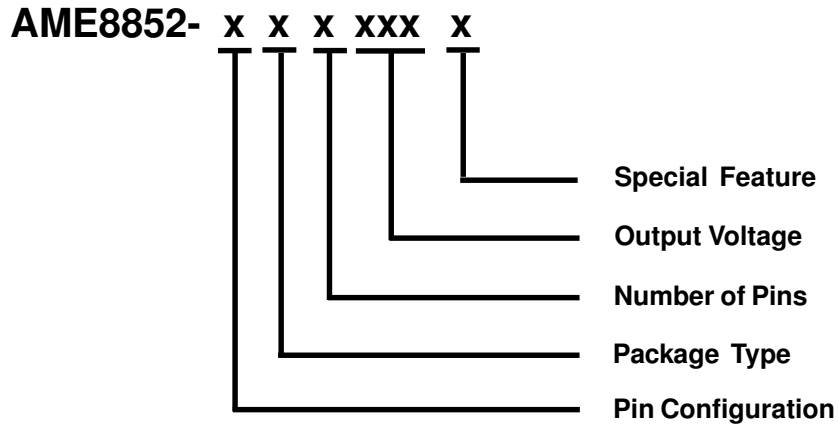
AME8852
■ Ordering Information

Pin Configuration	Package Type	Number of Pins	Output Voltage	Special Feature
A (SC-70-4) 1. EN 2. GND 3. OUT 4. IN	E: SOT-2X I: SC-70 (SC-82)	T: 3 U: 4 V: 5	080: 0.8V 090: 0.9V 100: 1.0V 110: 1.1V 120: 1.2V 130: 1.3V 140: 1.4V 150: 1.5V : : : : 420: 4.2V 430: 4.3V	N/A: SOT-2X K: 0.9mm max height (for TSOT-2XA Only)
A (SOT-25) (TSOT-25A) 1. IN 2. GND 3. EN 4. NC 5. OUT				
A (SOT-23) 1. GND 2. OUT 3. IN				

AME8852
■ Absolute Maximum Ratings

Parameter		Maximum	Unit
Input Voltage		-0.3 to 6	V
Output Current		$P_D/(V_{IN}-V_{OUT})$	mA
Output Voltage		GND-0.3 to $V_{IN}+0.3$	V
ESD Classification	HBM	2	kV
	MM	200	V

■ Recommended Operating Conditions

Parameter	Symbol	Rating	Unit
Ambient Temperature Range	T_A	- 40 to +85	°C
Junction Temperature Range	T_J	- 40 to +125	°C
Storage Temperature Range	T_{STG}	- 65 to +150	°C

■ Thermal Information

Parameter	Package	Die Attach	Symbol	Maximum	Unit
Thermal Resistance* (Junction to Case)	SC-70-4 (SC-82)	Conductive Epoxy	θ_{JC}	224	°C / W
	SOT-25			81	
	TSOT-25A			81	
	SOT-23	Non-Conductive Epoxy		140	
Thermal Resistance (Junction to Ambient)	SC-70-4 (SC-82)	Conductive Epoxy	θ_{JA}	331	°C / W
	SOT-25			260	
	TSOT-25A			230	
	SOT-23	Non-Conductive Epoxy		280	
Internal Power Dissipation	SC-70-4 (SC-82)	Conductive Epoxy	P_D	300	mW
	SOT-25			400	
	TSOT-25A			455	
	SOT-23	Non-Conductive Epoxy		400	
Lead Temperature (Soldering, 10Sec.)**				260	°C

* Measure θ_{JC} on backside center of molding compound if IC has no tab.

** MIL-STD-202G210F

AME8852
■ Electrical Specifications

$V_{IN} = V_{OUT(NOM)} + 1V$, (for $V_{OUT} < 2V$, $V_{IN} = 2.5V$), $I_{OUT} = 1mA$, and $C_{OUT} = 1\mu F$, $C_{IN} = 1\mu F$ unless otherwise noted.
Typical values are at $T_A = 25^\circ C$.

Parameter	Symbol	Test Condition	Min	Typ	Max	Units
Input Voltage	V_{IN}		2.5		5.5	V
Output Accuracy	$V_{OUT,ACC}$	$I_{OUT} = 1mA$	-2.0		2.0	%
Output Voltage Range	V_{OUT}		0.8		4.3	V
Dropout Voltage (Note 1)	V_{DROP}	$I_{OUT} = 150mA$, $0.8V \leq V_{OUT(NOM)} \leq 1.9V$			Note2	mV
		$I_{OUT} = 150mA$ $1.9V < V_{OUT(NOM)} \leq 2.4V$			400	
		$I_{OUT} = 150mA$ $2.4V < V_{OUT(NOM)} \leq 2.8V$			300	
		$I_{OUT} = 150mA$, $2.8V < V_{OUT(NOM)}$		110	230	
Output Current	I_{OUT}		150			mA
Quiescent Current	I_Q	$I_{OUT} = 0mA$		60	90	μA
Line Regulation $\frac{\Delta V_{OUT}}{\Delta V_{IN}} \times 100\%$ $\frac{\Delta V_{OUT}}{V_{OUT}}$	REG_{LINE}	$I_{OUT} = 1mA$, $0.8V \leq V_{OUT} \leq 1.2V$, $2.5V \leq V_{IN} \leq 3.5V$		0.125	0.25	% / V
		$I_{OUT} = 1mA$, $1.2V < V_{OUT} \leq 2.0V$, $2.5V \leq V_{IN} \leq 3.5V$		0.1	0.2	
		$I_{OUT} = 1mA$, $2.0V < V_{OUT} \leq 4.2V$, $V_{IN(MIN)} \leq V_{IN} \leq V_{IN(MIN)} + 1V$		0.05	0.1	
		$I_{OUT} = 1mA$, $4.2V < V_{OUT} \leq 4.5V$, $V_{IN(MIN)} \leq V_{IN} \leq 5.5V$		0.05	0.1	
Load Regulation $\frac{\Delta V_{OUT}}{V_{OUT}} \times 100\%$ $\frac{\Delta V_{OUT}}{\Delta I_{OUT}}$	REG_{LOAD}	$1mA \leq I_{OUT} \leq 150mA$ $0.8V \leq V_{OUT(NOM)} \leq 1.2V$		2.5	5	% / A
		$1mA \leq I_{OUT} \leq 150mA$ $1.2V \leq V_{OUT(NOM)} \leq 2.0V$		1.7	4	
		$1mA \leq I_{OUT} \leq 150mA$ $2.0V < V_{OUT(NOM)}$		1.0	3	

AME8852

■ Electrical Specifications

Parameter	Symbol	Test Condition	Min	Typ	Max	Units	
Power Supply Rejection Ratio	PSRR	$C_{OUT}=1\mu F, V_{OUT}=1V$ $I_{OUT}=10mA$ $V_{IN}=2.8V$	F=100Hz		60		dB
			F=1KHz		60		
			F=10KHz		60		
Output Voltage Noise	eN	$I_{OUT}=10mA, V_{OUT}=0.8V,$ f=1Hz to 100KHz		100		μV_{RMS}	
Enable High (Enabled)	$V_{EN,HI}$	$V_{IN(MIN)} \leq V_{IN} \leq 5.5V$	1.4		V_{IN}	V	
Enable Low (Shutdown)	$V_{EN,LO}$	$V_{IN(MIN)} \leq V_{IN} \leq 5.5V$	0		0.4		
Enable Input Bias Current	$I_{EN,HI}$	$V_{EN}=V_{IN}$			1	μA	
	$I_{EN,LO}$	$V_{EN}=0V$			2		
Shutdown Current	I_{SHDN}	$V_{IN}=5.0V, V_{EN}=0V$		0.1	1	μA	
Shutdown Output Voltage	$V_{OUT,SD}$	$I_{OUT}=0.4mA, V_{EN}=0$			0.4	V	
Protection							
Output Current Limit	I_{LIM}	$V_{OUT}=0.9 \times V_{OUT(NOM)}$	250			mA	
Thermal Shutdown Temperature	T_{SHDN}	Shutdown, temperature increasing		150		$^{\circ}C$	
Thermal Shutdown Hysteresis	$T_{SHDN(HYS)}$			20			

Note1: Dropout Voltage is measured at $V_{OUT}=V_{OUT(NOM)} \times 98\%$

Note2: For V_{OUT} below 2.0V, Dropout Voltage is the input_(MIN) to output differential.

■ Detailed Description

The AME8852 family of CMOS regulators contain a PMOS pass transistor, voltage reference, error amplifier, over-current protection, thermal shutdown, and Power Good detection circuitry.

The P-channel pass transistor receives data from the error amplifier, over-current shutdown, and thermal protection circuits. During normal operation, the error amplifier compares the output voltage to a precision reference. Over-current and Thermal shutdown circuits become active when the junction temperature exceeds 150°C, or the current exceeds 150mA. During thermal shutdown, the output voltage remains low. Normal operation is restored when the junction temperature drops more 20°C.

Capacitor Selection and Regulator Stability

The AME8852 is stable with an output capacitor to ground of 1µF or greater. Ceramic capacitors have the lowest ESR, and will offer the best AC performance. Conversely, Aluminum Electrolytic capacitors exhibit the highest ESR, resulting in the poorest AC response. Unfortunately, large value ceramic capacitors are comparatively expensive. One option is to parallel a 0.1µF ceramic capacitor with a 10µF Aluminum Electrolytic. The benefit is low ESR, high capacitance, and low overall cost.

A second capacitor is recommended between the input and ground to stabilize V_{IN} . The input capacitor should be at least 0.1µF to have a beneficial effect.

Enable Pin

The Enable Pin is Active High. When activated pulled low, the MOS pass transistor shuts off, and all internal circuits are powered down. In this state, the stand by current is than 1µA. When EN pin float outside, It's pulled high.

Capacitor Selection and Regulator Stability

The maximum output power of the AME8852 is limited by the maximum power dissipation of the package. By calculation the power dissipation of the package as a function of the input voltage, output voltage and output current, the maximum input voltage can be obtained. The maximum power dissipation should not exceed the package's maximum power rating.

$$P_{MAX} = (V_{IN(MAX)} - V_{OUT}) \times I_{OUT}$$

Where:

$V_{IN(MAX)}$ = maximum input voltage

P_{MAX} = maximum power dissipation of the package

■ Characterization Curve

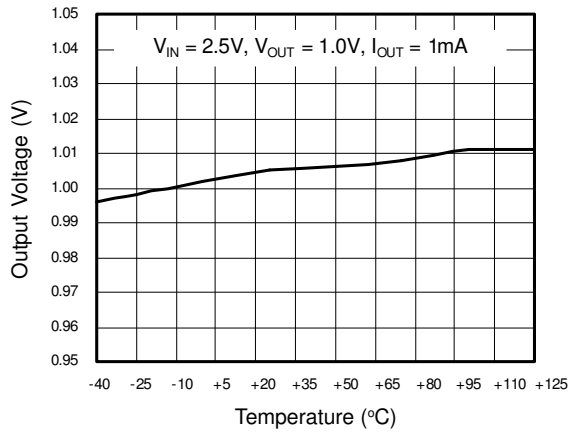
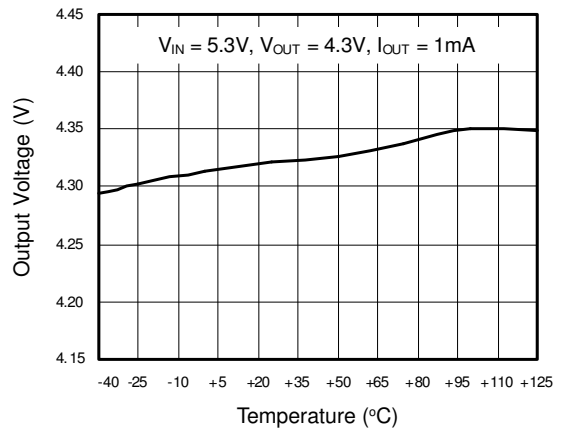
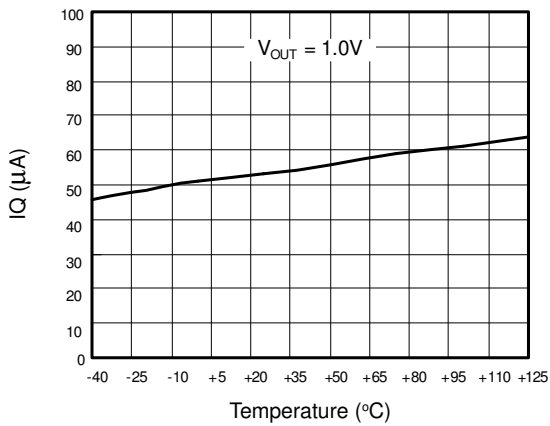
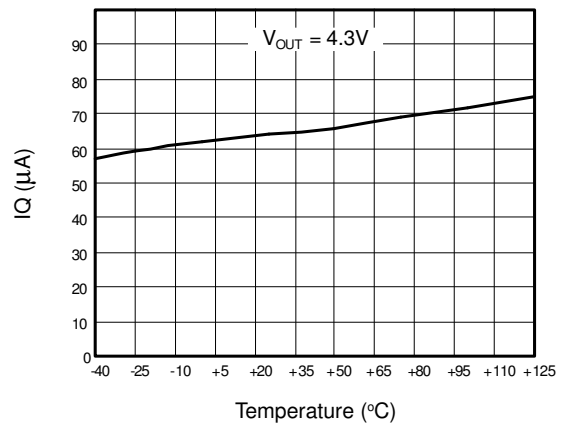
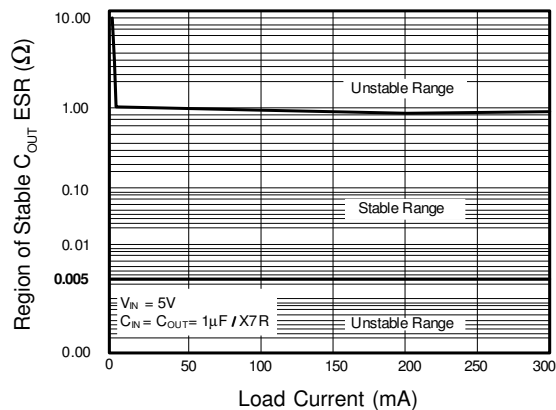
Output Voltage

Output Voltage

Quiescent Current

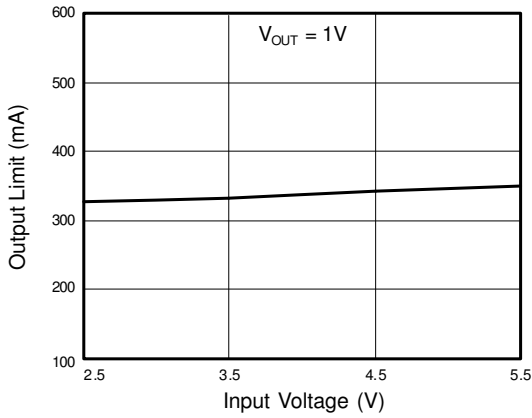
Quiescent Current

Stability vs. ESR vs. Load Current

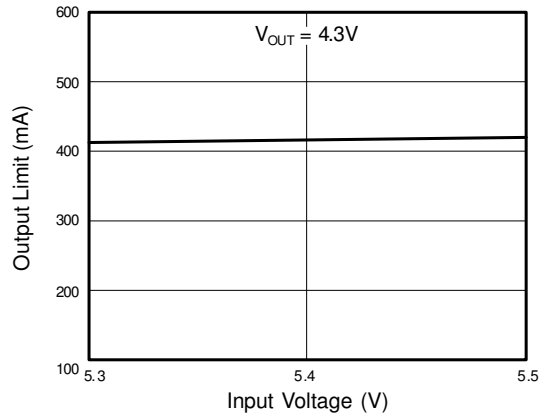
■ Characterization Curve (Contd.)

Current Limit vs. Input Voltage



Current Limit vs. Input Voltage



Dropout Voltage

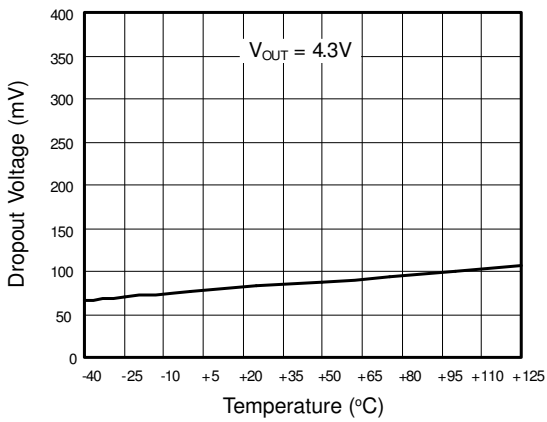

PSRR vs. Frequency

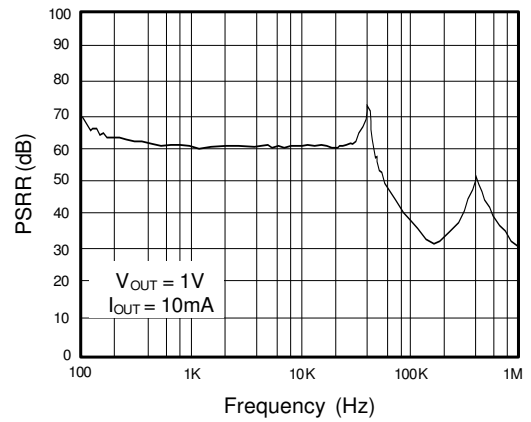

■ Characterization Curve (Contd.)

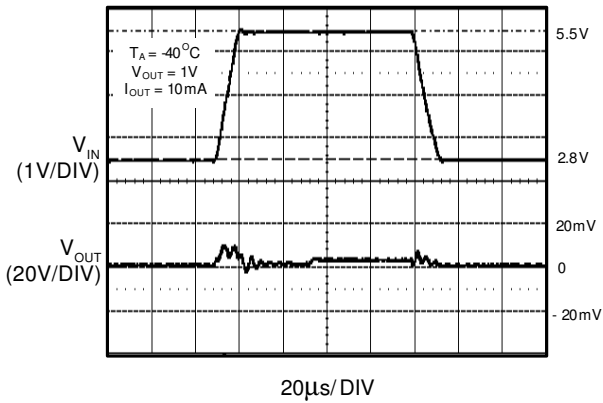
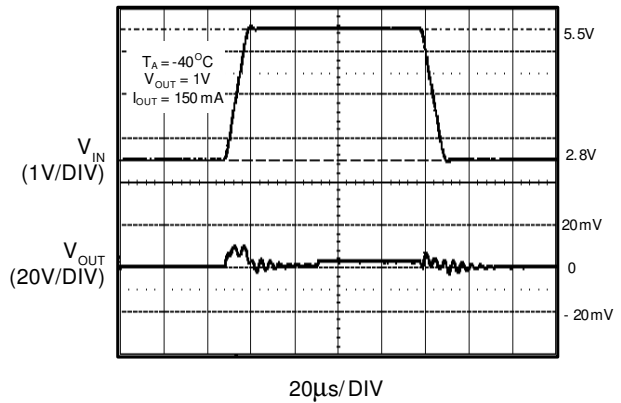
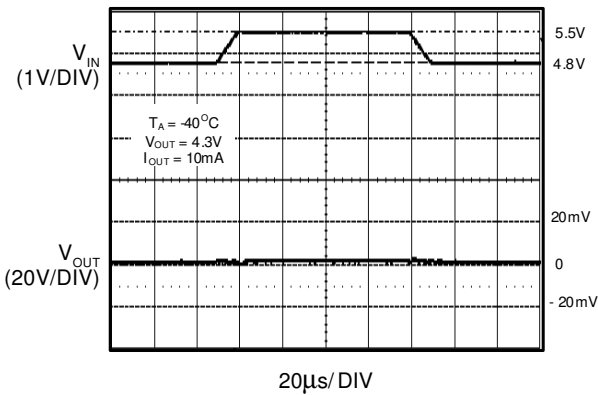
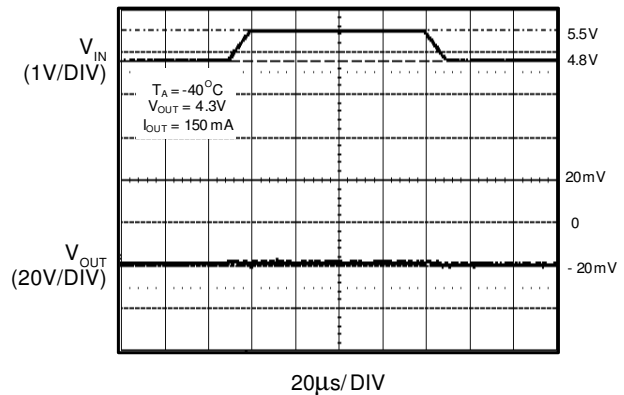
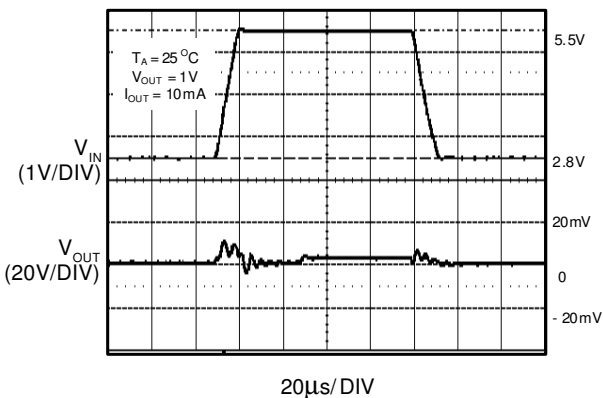
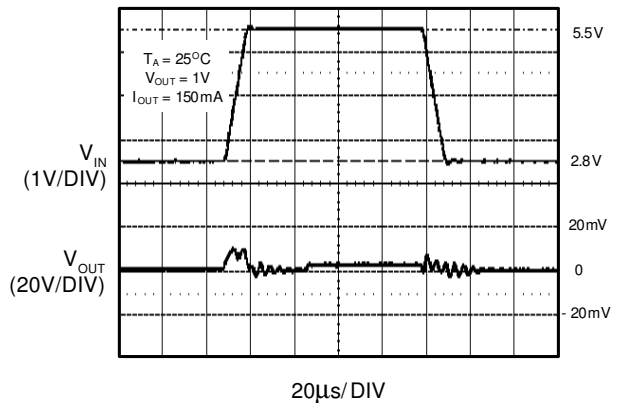
Line Transient Response

Line Transient Response

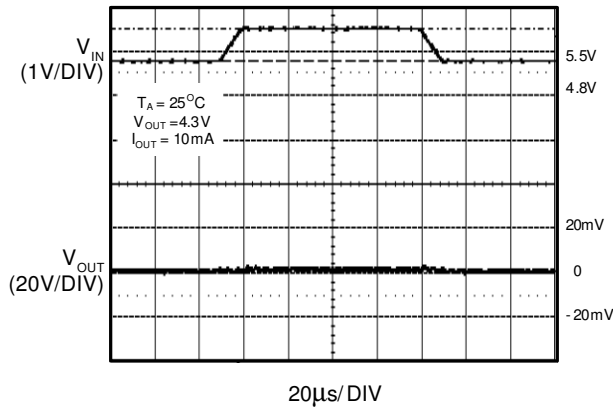
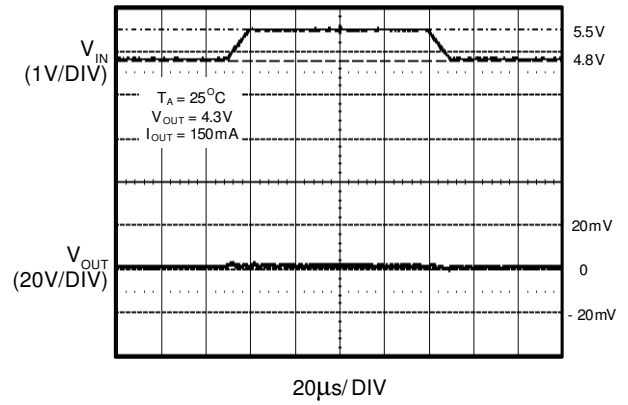
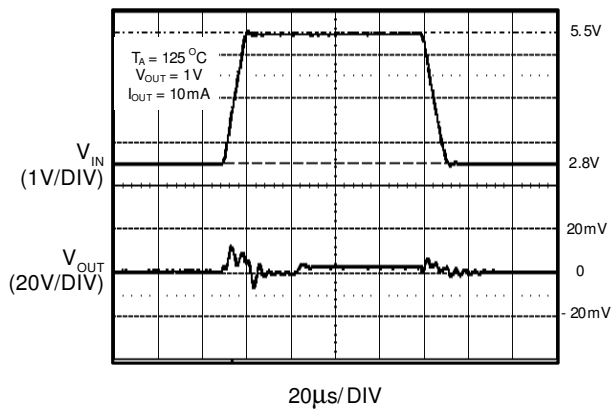
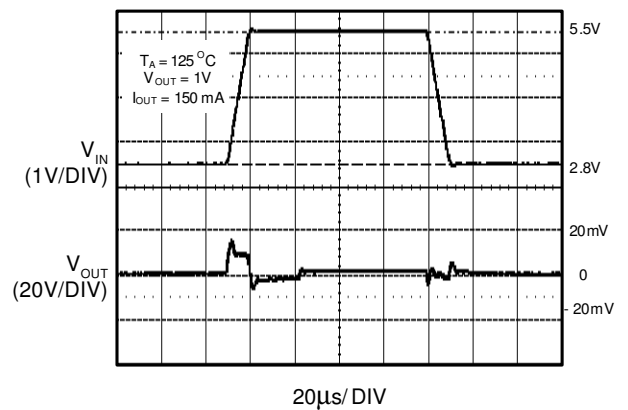
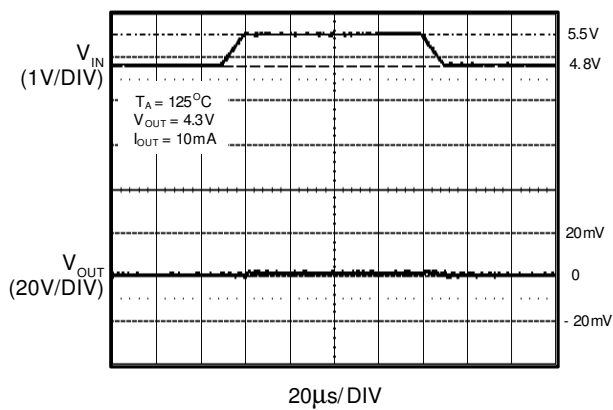
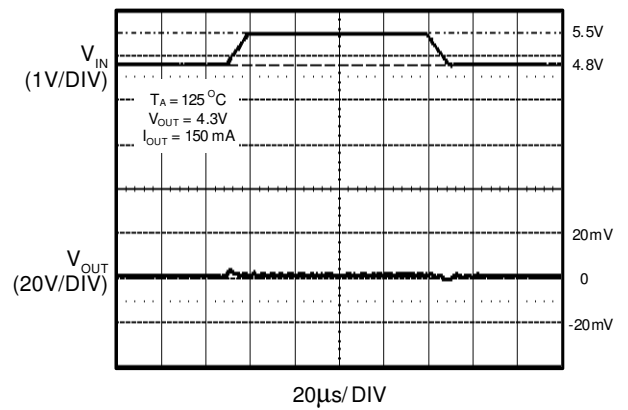
Line Transient Response

Line Transient Response

Line Transient Response

Line Transient Response

■ Characterization Curve (Contd.)

Line Transient Response

Line Transient Response

Line Transient Response

Line Transient Response

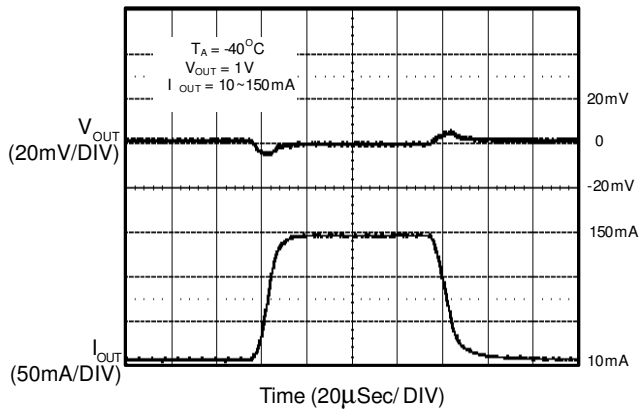
Line Transient Response

Line Transient Response

AME8852

■ Characterization Curve (Contd.)

Load Transient Response



Load Transient Response

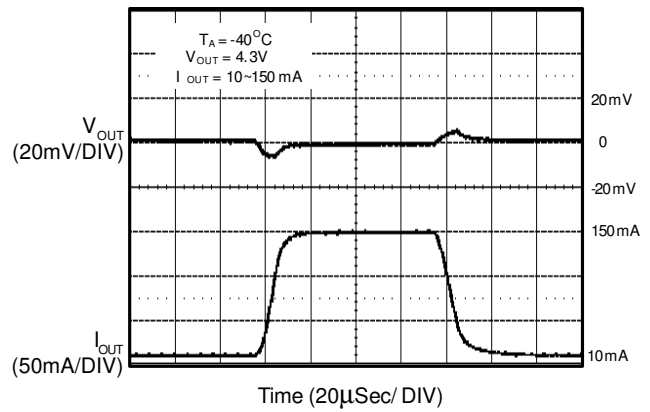

Load Transient Response

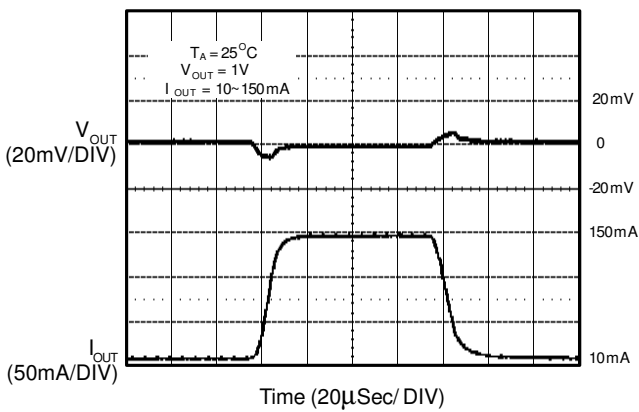

Load Transient Response

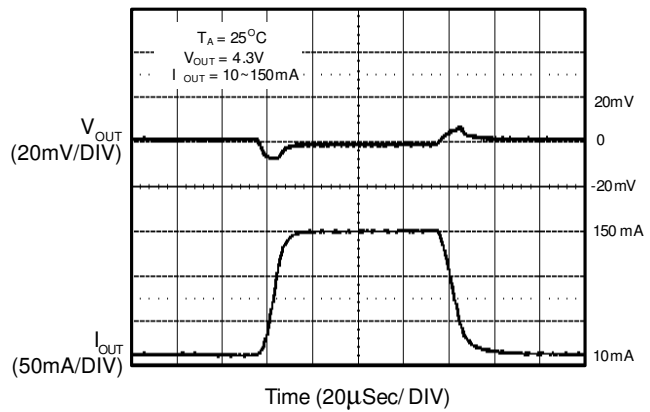

Load Transient Response

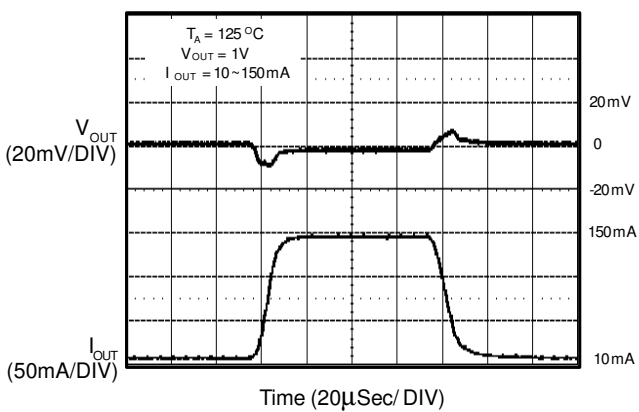

Load Transient Response

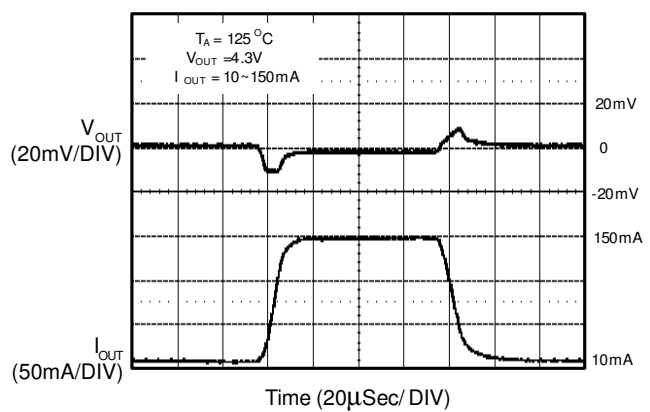

■ Characterization Curve (Contd.)

Chip Enable Transient Response

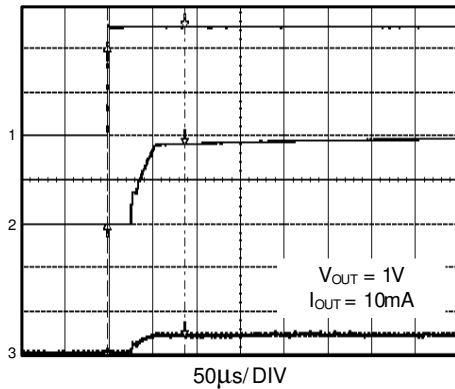

- 1) EN= 1V/Div
- 2) $V_{OUT} = 500mV/Div$
- 3) $I_{OUT} = 20mA/Div$

Chip Enable Transient Response

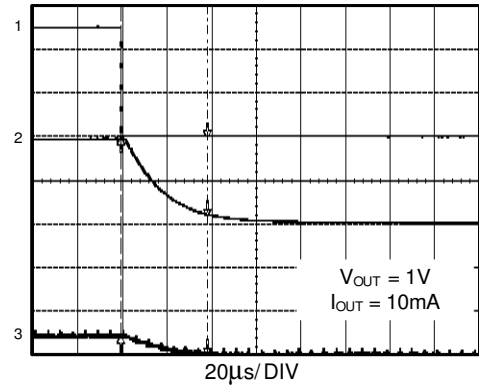

- 1) EN= 1V/Div
- 2) $V_{OUT} = 500V/Div$
- 3) $I_{OUT} = 20mA/Div$

Chip Enable Transient Response

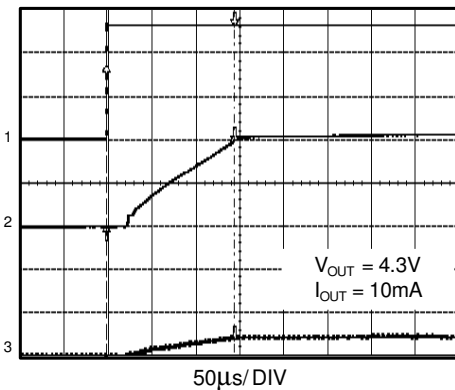

- 1) EN= 2V/Div
- 2) $V_{OUT} = 2V/Div$
- 3) $I_{OUT} = 20mA/Div$

Chip Enable Transient Response

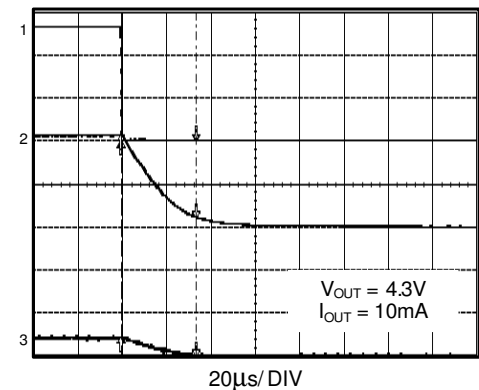

- 1) EN= 2V/Div
- 2) $V_{OUT} = 2V/Div$
- 3) $I_{OUT} = 20mA/Div$

■ Characterization Curve (Contd.)

Chip Enable Transient Response

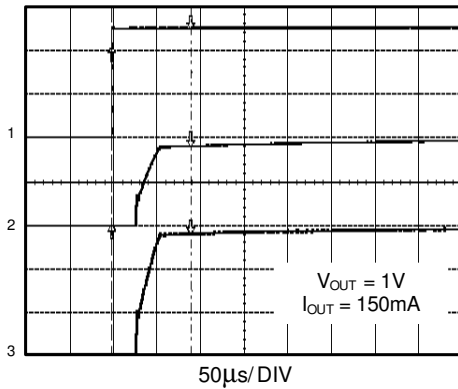

- 1) EN= 1V/Div
- 2) V_{OUT} = 500mV/Div
- 3) I_{OUT} = 50mA/Div

Chip Enable Transient Response

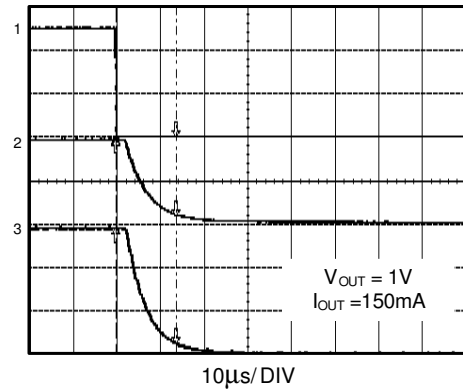

- 1) EN= 1V/Div
- 2) V_{OUT} = 500mV/div
- 3) I_{OUT} = 50mA/Div

Chip Enable Transient Response

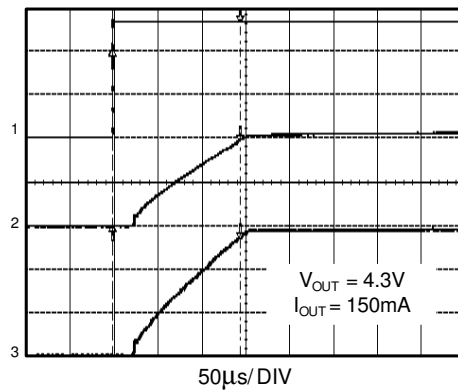

- 1) EN= 2V/Div
- 2) V_{OUT} = 2V/Div
- 3) I_{OUT} = 50mA/Div

Chip Enable Transient Response

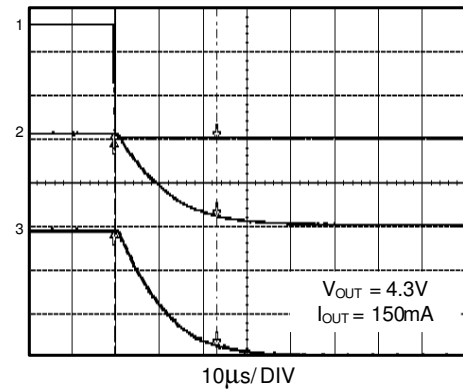

- 1) EN= 2V/Div
- 2) V_{OUT} = 2V/Div
- 3) I_{OUT} = 50mA/Div

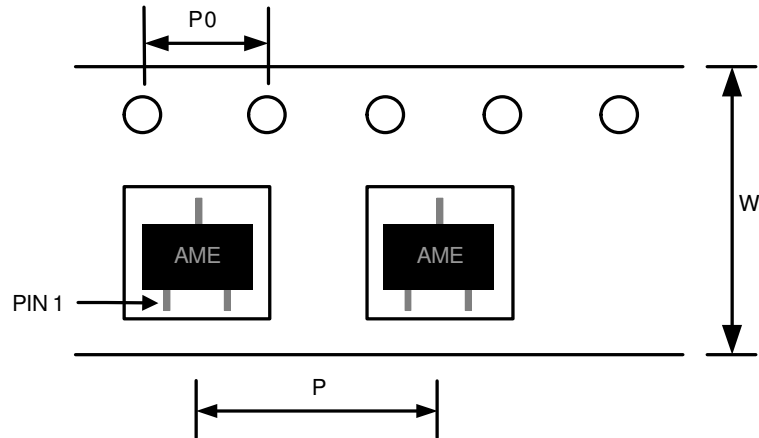
AME8852
■ Tape and Reel Dimension
SOT-23

Carrier Tape, Number of Components Per Reel and Reel Size

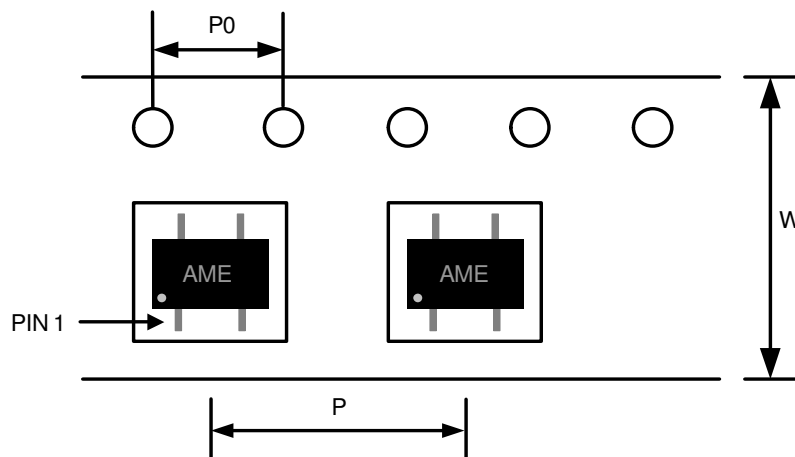
Package	Carrier Width (W)	Pitch (P)	Pitch (P0)	Part Per Full Reel	Reel Size
SOT-23	8.0±0.1 mm	4.0±0.1 mm	4.0±0.1 mm	3000pcs	180±1 mm

SC-70-4 (SC-82)

Carrier Tape, Number of Components Per Reel and Reel Size

Package	Carrier Width (W)	Pitch (P)	Pitch (P0)	Part Per Full Reel	Reel Size
SC-70-4	8.0±0.1 mm	4.0±0.1 mm	4.0±0.1 mm	3000pcs	180±1 mm

AME8852

■ Tape and Reel Dimension (Contd.)

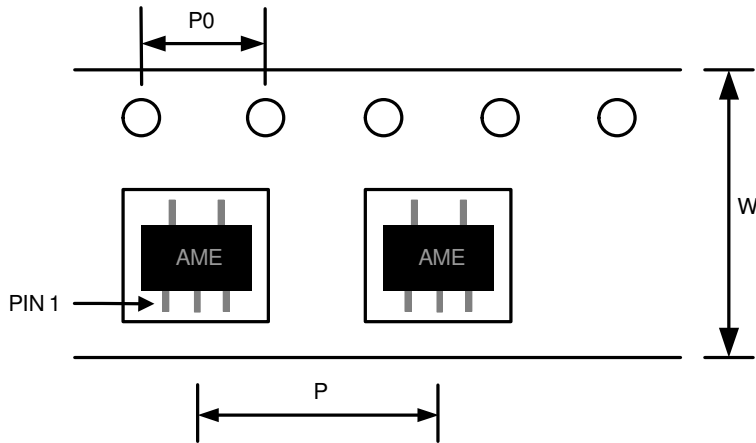
SOT-25



Carrier Tape, Number of Components Per Reel and Reel Size

Package	Carrier Width (W)	Pitch (P)	Pitch (P0)	Part Per Full Reel	Reel Size
SOT-25	8.0±0.1 mm	4.0±0.1 mm	4.0±0.1 mm	3000pcs	180±1 mm

TSOT-25A

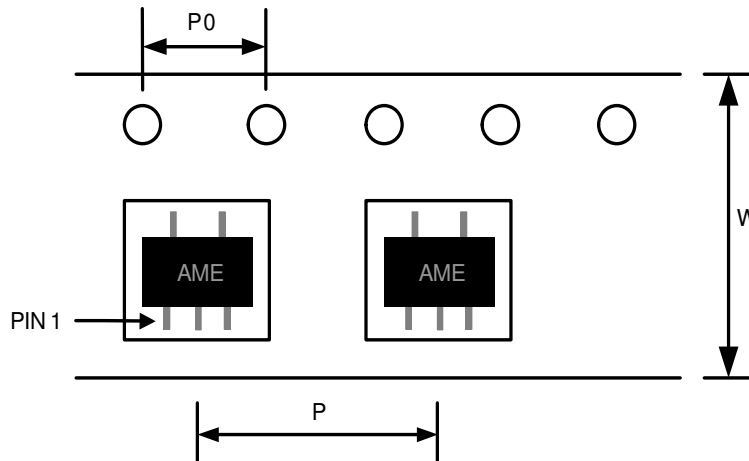

Carrier Tape, Number of Components Per Reel and Reel Size

Package	Carrier Width (W)	Pitch (P)	Pitch (P0)	Part Per Full Reel	Reel Size
TSOT-25A	8.0±0.1 mm	4.0±0.1 mm	4.0±0.1 mm	3000pcs	180±1 mm

AME8852

■ Package Dimension

SOT-23

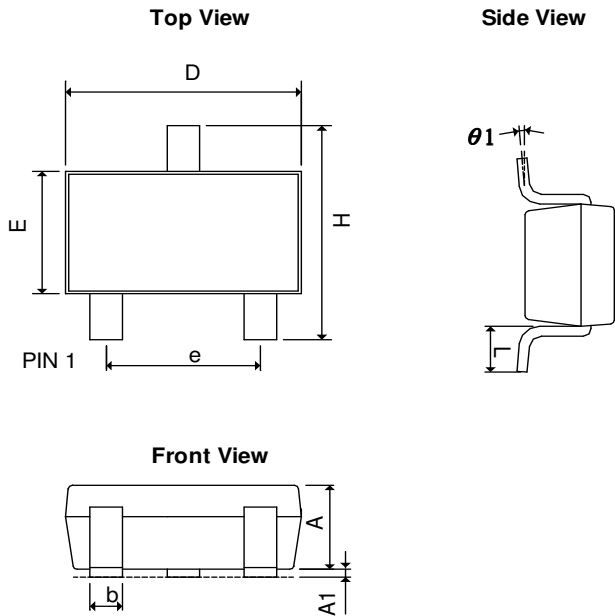

SYMBOLS	MILLIMETERS		INCHES	
	MIN	MAX	MIN	MAX
A	0.90	1.40	0.0354	0.0551
A ₁	0.00	0.15	0.0000	0.0059
b	0.30	0.50	0.0118	0.0197
D	2.70	3.10	0.1063	0.1220
E	1.40	1.80	0.0551	0.0709
e	1.90 BSC		0.0748 BSC	
H	2.40	3.00	0.0945	0.1181
L	0.35BSC		0.0138 BSC	
$\theta 1$	0°	10°	0°	10°

■ Lead Pattern

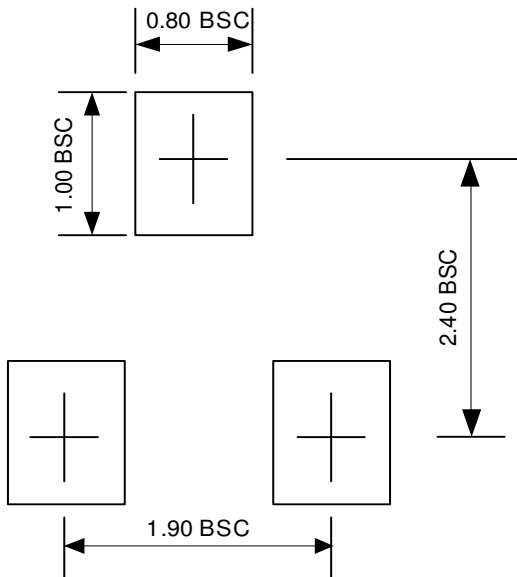

Note:

- Lead pattern unit description:
BSC: Basic. Represents theoretical exact dimension or dimension target.
- Dimensions in Millimeters.
- General tolerance $\pm 0.05\text{mm}$ unless otherwise specified.

AME8852

■ Package Dimension (Contd.)

SC-70-4

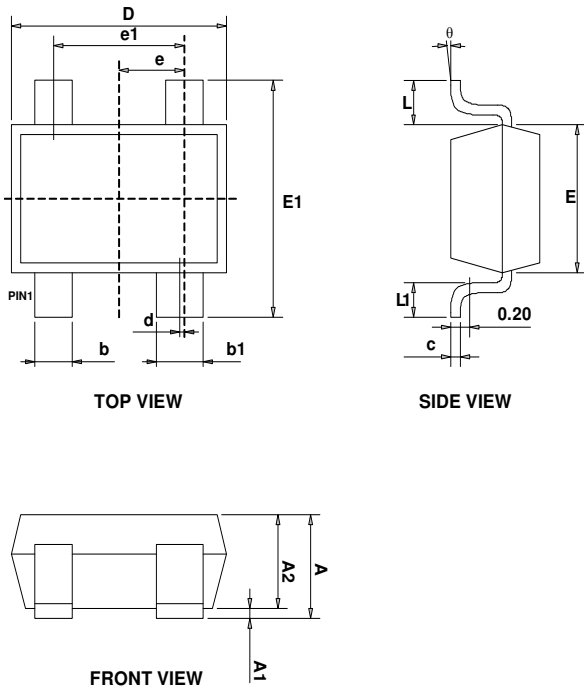

SYMBOLS	MILLIMETERS		INCHES	
	MIN	MAX	MIN	MAX
A	0.900	1.100	0.035	0.043
A1	0.000	0.100	0.000	0.004
A2	0.900	1.000	0.035	0.039
b	0.250	0.400	0.010	0.016
b1	0.350	0.500	0.014	0.020
c	0.080	0.150	0.003	0.006
d	0.050 TYP		0.002 TYP	
D	2.000	2.200	0.079	0.087
E	1.150	1.350	0.045	0.053
E1	2.150	2.450	0.085	0.096
e	0.650 TYP		0.026 TYP	
e1	1.200	1.400	0.047	0.055
L	0.525 REF		0.021 REF	
L1	0.260	0.460	0.010	0.018
θ	0°	8°	0°	8°

SC-70-4(SC-82)

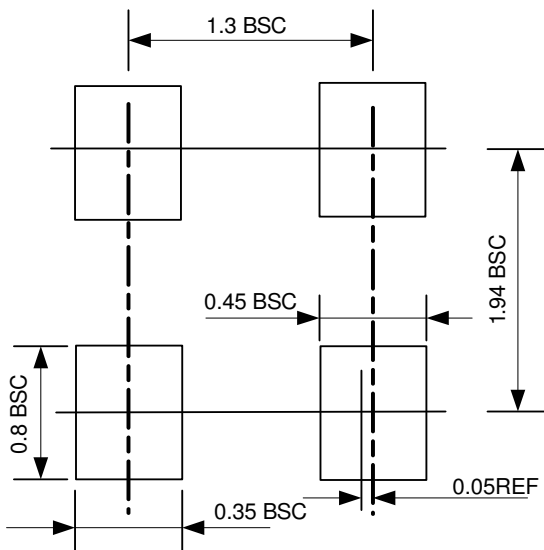

Note:

1. Lead pattern unit description:

BSC: Basic. Represents theoretical exact dimension or dimension target.

2. Dimensions in Millimeters.

3. General tolerance $\pm 0.05\text{mm}$ unless otherwise specified.

AME8852

■ Package Dimension (Contd.)

SOT-25

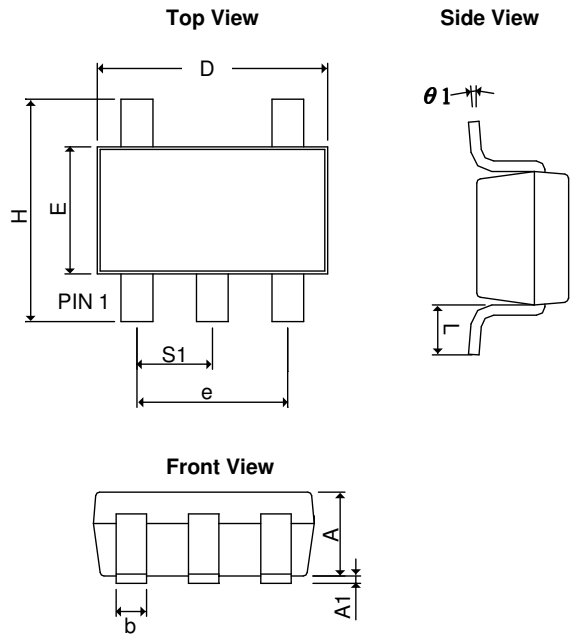

SYMBOLS	MILLIMETERS		INCHES	
	MIN	MAX	MIN	MAX
A	0.90	1.30	0.0354	0.0512
A ₁	0.00	0.15	0.0000	0.0059
b	0.30	0.55	0.0118	0.0217
D	2.70	3.10	0.1063	0.1220
E	1.40	1.80	0.0551	0.0709
e	1.90 BSC		0.0748 BSC	
H	2.60	3.00	0.1024	0.1181
L	0.37 BSC		0.0146 BSC	
$\theta 1$	0°	10°	0°	10°
S ₁	0.95 BSC		0.0374 BSC	

■ Lead Pattern

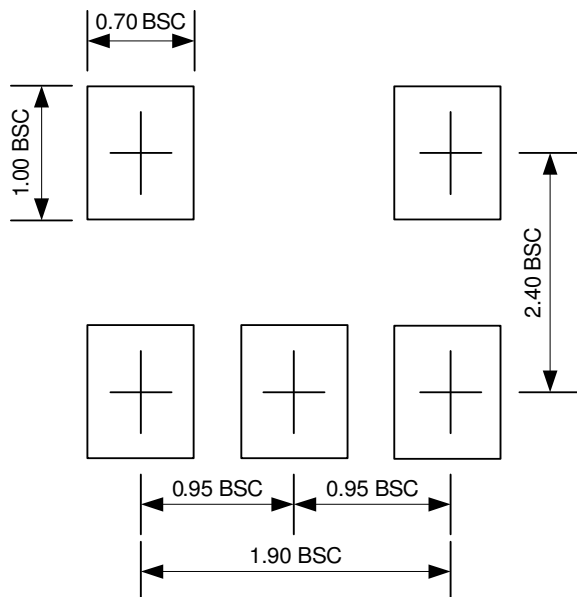

Note:

- Lead pattern unit description:
BSC: Basic. Represents theoretical exact dimension or dimension target.
- Dimensions in Millimeters.
- General tolerance $\pm 0.05\text{mm}$ unless otherwise specified.

AME8852

■ Package Dimension (Contd.)

TSOT-25A

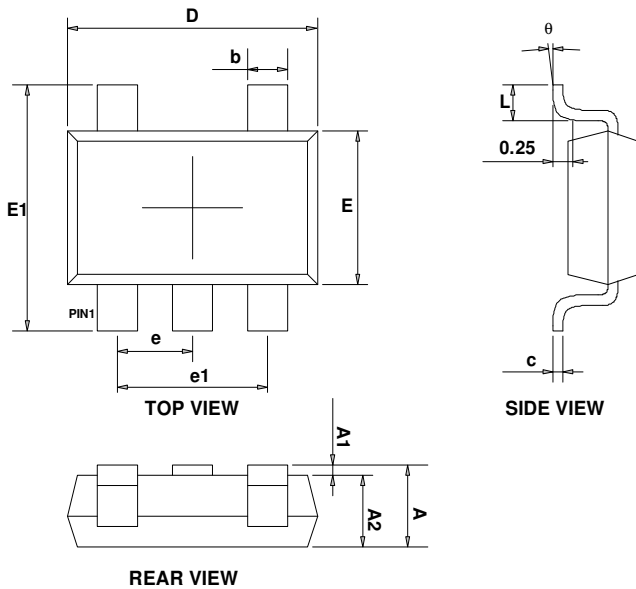

SYMBOLS	MILLIMETERS		INCHES	
	MIN	MAX	MIN	MAX
A	0.700	0.900	0.028	0.035
A1	0.000	0.100	0.000	0.004
A2	0.700	0.800	0.028	0.031
b	0.350	0.500	0.014	0.020
c	0.080	0.200	0.003	0.008
D	2.820	3.020	0.111	0.119
E	1.600	1.700	0.063	0.067
E1	2.650	2.950	0.104	0.116
e	0.95 BSC		0.037 BSC	
e1	1.90 BSC		0.075 BSC	
L	0.300	0.600	0.012	0.024
θ	0°	8°	0°	8°

■ Lead Pattern

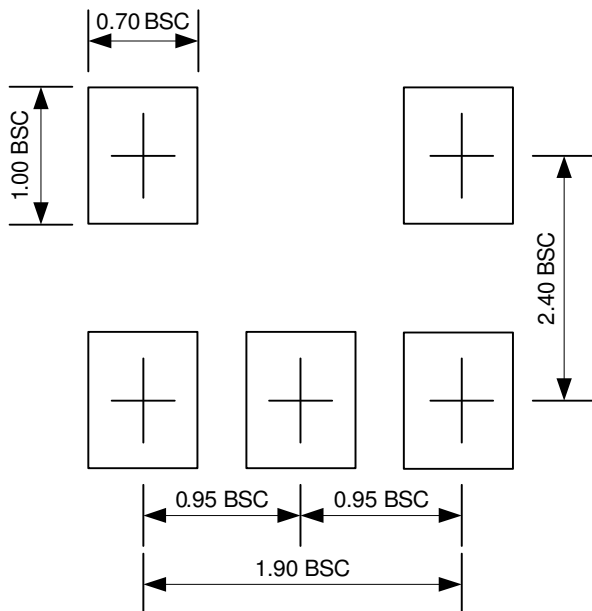

Note:

1. Lead pattern unit description:
BSC: Basic. Represents theoretical exact dimension or dimension target.
2. Dimensions in Millimeters.
3. General tolerance $\pm 0.05\text{mm}$ unless otherwise specified.



www.ame.com.tw
E-Mail: sales@ame.com.tw

Life Support Policy:

These products of AME, Inc. are not authorized for use as critical components in life-support devices or systems, without the express written approval of the president of AME, Inc.

AME, Inc. reserves the right to make changes in the circuitry and specifications of its devices and advises its customers to obtain the latest version of relevant information.

© AME, Inc. , April 2016

Document: TM001-DS8852-B.01

Corporate Headquarter
AME, Inc.

8F, 12, WenHu St., Nei Hu
Taipei, Taiwan. 114
Tel: 886 2 2627-8687
Fax: 886 2 2659-2989