

HH-2131-3

This filter is designed to operate with the VICOR "FARM" Module.

The filter and "FARM" Module have been tested for conducted emissions to CE102 of MIL-STD-461F and determined to be in compliance.

It should be noted that though the confidence level of the testing is high, the testing was not performed by a certified test house.

The filter will operate at 5A and 50°C or at the load current level of 3A and 80°C.

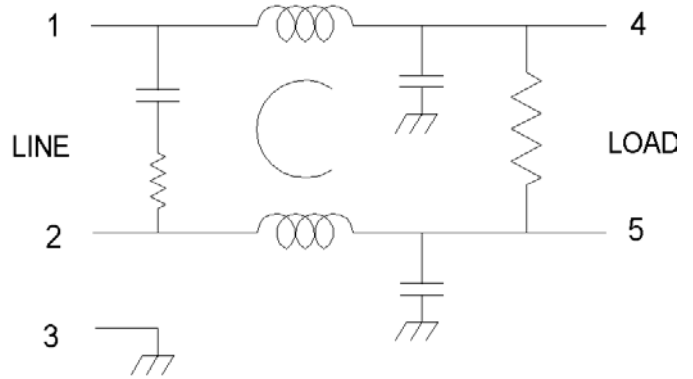

Operating Voltage: _____ 125/250 VAC

Maximum Load Current @ 50°C: _____ 5A
 Operating Frequency: _____ 50 - 400 Hz

Operating Temperature @ 3 amp: _____ -55° TO 80°C
 Storage Temperature: _____ -55° TO 100°C

ALTITUDE: 50,000 FT
 HUMIDITY: 95% NON CONDENSATION
 Filter Weight: _____ 175 gram
 MTBF = 23,337,223 hours at 30°C GB

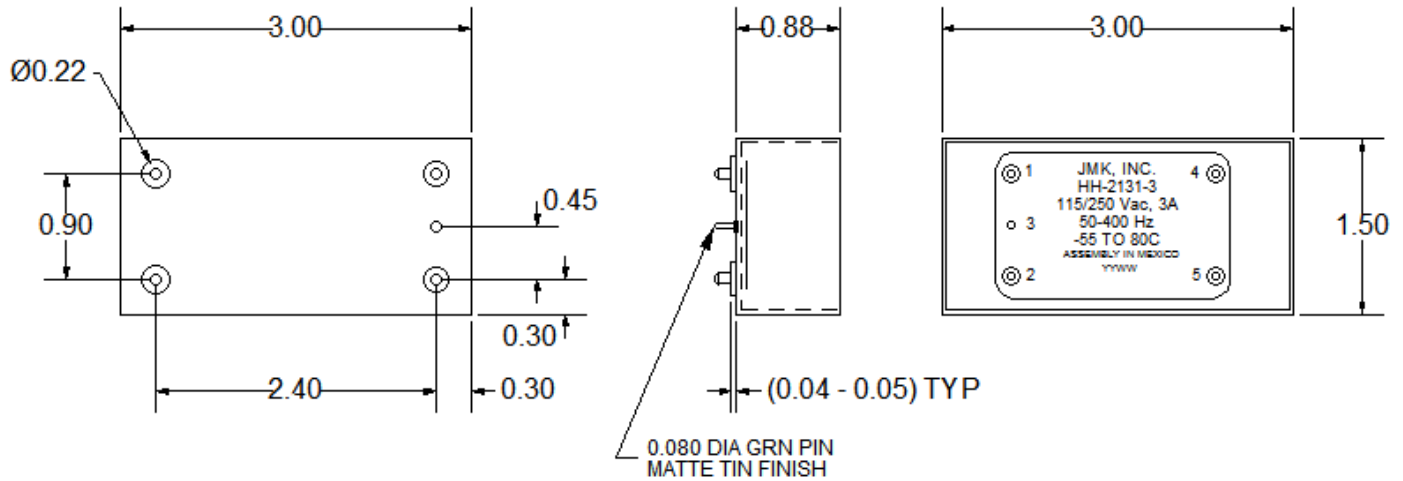
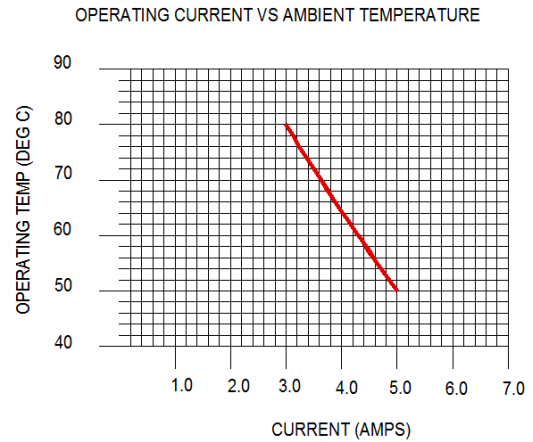

USA JMK Inc 15 Caldwell Dr. Amherst, NH 03031 PH: 603 886-4100 FX: 603 886-4115
 email: info@jmkfilters.com
 EUR JMK Inc Scotland UK PH: 44-(0) 7785310729
 email: johnp@jmkfilters.com