

High-Performance, Dual-Channel DC-DC Converter for Mobile and Portable Applications

General Description

DA9132 is a power management IC (PMIC) suitable for supplying CPUs, GPUs, DDR memory rails in single in-line pin package (SIPP) modules, mobile, portable and consumer applications.

DA9132 integrates two single-phase buck converters, each phase requiring a small external 0.22 μH inductor. Each buck is capable of delivering up to 3 A output current at a 0.3 V to 1.9 V output voltage range. The 2.8 V to 5.5 V input voltage range is suitable for a wide variety of low-voltage systems.

With remote sensing, the DA9132 guarantees the highest accuracy and supports multiple PCB routing scenarios without loss of performance.

The pass devices are fully integrated, so no external FETs or Schottky diodes are needed.

A programmable soft start-up can be enabled, which limits the inrush current from the input node and secures a slope-controlled rail activation.

The dynamic voltage control (DVC) supports adaptive adjustment of the supply voltage dependent on the processor load, via either a direct register write using the communication interface (I²C-compatible) or with a programmable input pin.

A configurable GPI allows multiple I²C address selection for multiple instances of DA9132 in the same application.

DA9132 has integrated over-temperature and over-current protection for increased system reliability, without the need for external sensing components.

Key Features

- 2.8 V to 5.5 V input voltage
- 0.3 V to 1.9 V output voltage
- 4 MHz nominal switching frequency
- ± 1 % accuracy (static)
- ± 5 % accuracy (dynamic)
- I²C-compatible interface (FM+)
- Programmable GPIOs
- Programmable soft-start
- Voltage, current, and temperature supervision
- -40 °C to +105 °C ambient temperature range
- Key safety features
 - Output under-voltage and over-voltage protection
 - Input under-voltage protection
 - 2-step over-temperature protection
- AEC-Q100 Grade 2 qualified version also available for Automotive applications (DA9132-A)
- 24-pin FCQFN package (nom. 3.3 mm x 4.8 mm)
 - Wettable flanks

Benefits

- High Efficiency buck converters deliver outstanding thermal performance
- Fully integrated switching FET's means no external FETs or Schottky diodes are required
- Remote sensing guarantees the highest accuracy and supports multiple PCB routing scenarios without loss of performance.
- Fully programmable soft-start limits the inrush current from the input to give a slope-controlled output voltage.
- Dynamic voltage control (DVC) enables adaptive adjustment of the device output voltage depending on the load. This increases efficiency when the downstream circuitry enters low power or idle mode, resulting in power savings.
- Configurable GPIOs support a range of features including I²C, DVC and Power-Good indicator.

High-Performance, Dual-Channel DC-DC Converter for Mobile and Portable Applications

- Optimized BoM cost and footprint: Each output requires a very small inductor and capacitor delivering parts and cost savings
- Cycle by cycle current limiting for superior over-current protection

Applications

- Switches and routers
- Smart metering
- Industrial automation
- Wireless
- Consumer products
- SoC/FPGA based, high performance, automotive Electronic Control unit (ECU) requiring efficient, high current, power delivery
- SIPP modules (SoC, DRAM)

DA9132

High-Performance, Dual-Channel DC-DC Converter for Mobile and Portable Applications

System Diagrams

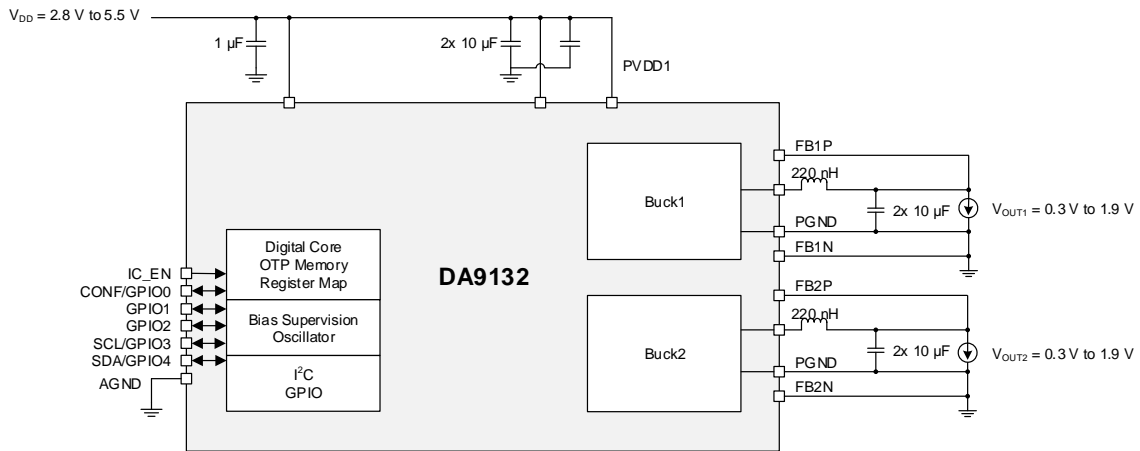

Figure 1: Simplified Schematic Diagram

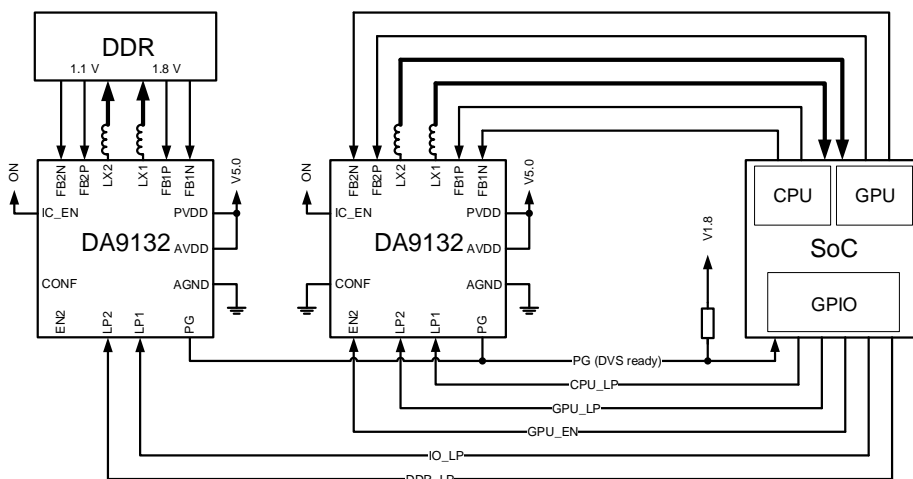

Figure 2: Typical Application Diagram (Port Control)

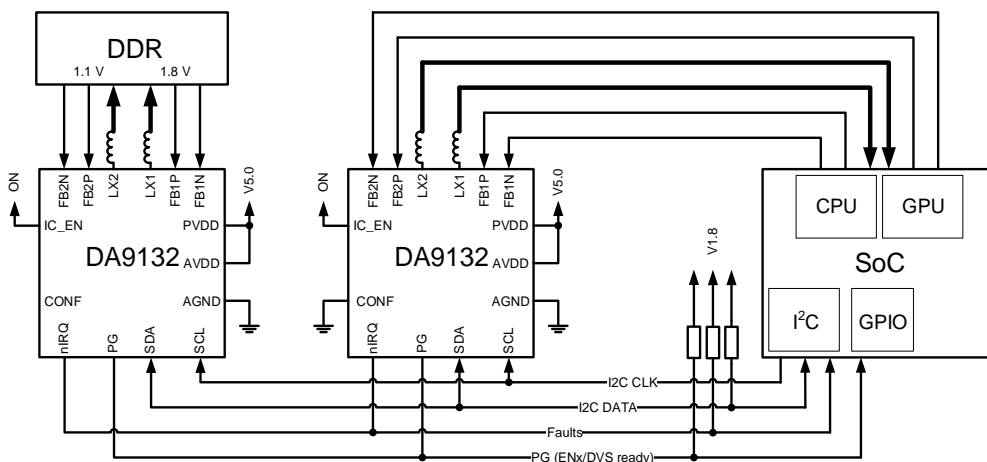

Figure 3: Typical Application Diagram (I²C Control)

High-Performance, Dual-Channel DC-DC Converter for Mobile and Portable Applications

Contents

General Description	1
Key Features	1
Benefits	1
Applications	2
System Diagrams	3
1 Terms and Definitions	7
2 Pinout	8
3 Characteristics	10
3.1 Absolute Maximum Ratings	10
3.2 Recommended Operating Conditions.....	10
3.3 Thermal Characteristics	11
3.3.1 Thermal Ratings	11
3.3.2 Power Dissipation	11
3.4 ESD Characteristics	11
3.5 Buck Characteristics	12
3.6 Performance and Supervision Characteristics.....	14
3.7 Digital I/O Characteristics.....	15
3.8 Timing Characteristics.....	16
3.9 Typical Performance	17
4 Functional Description	18
4.1 DC-DC Buck Converter.....	18
4.1.1 Switching Frequency	18
4.1.2 Operation Modes and Phase Selection	18
4.1.3 Output Voltage Selection	19
4.1.4 Soft Start-Up and Shutdown.....	19
4.1.5 Current Limit	19
4.1.6 Resistive Divider	20
4.1.7 Thermal Protection	21
4.2 Internal Circuits	21
4.2.1 IC_EN/Chip Enable/Disable.....	21
4.2.2 nIRQ/Interrupt.....	21
4.2.3 GPIO	26
4.3 Operating Modes.....	29
4.3.1 ON.....	29
4.3.2 OFF.....	29
4.4 I ² C Communication	29
4.4.1 I ² C Protocol.....	29
5 Register Definitions	31
5.1 Register Map.....	31
5.1.1 System	33
5.1.2 Buck1	43
5.1.3 Buck2.....	47
5.1.4 Serialization	51

High-Performance, Dual-Channel DC-DC Converter for Mobile and Portable Applications

6	Package Information	52
6.1	Package Outlines	52
6.2	Package Marking	53
6.3	Moisture Sensitivity Level.....	53
6.4	Soldering Information	53
7	Ordering Information	54
8	Application Information	55
8.1	Capacitor Selection	55
8.2	Inductor Selection	55

Table of Figures

Figure 1:	Simplified Schematic Diagram	3
Figure 2:	Typical Application Diagram (Port Control).....	3
Figure 3:	Typical Application Diagram (I ² C Control).....	3
Figure 4:	DA9132 Pinout Diagram (Bottom View).....	8
Figure 5:	Power Derating Curve	11
Figure 6:	DA9132 Efficiency, V _{OUT} = 0.8 V, PWM Mode	17
Figure 7:	DA9132 Efficiency, V _{OUT} = 0.8 V, Auto Mode	17
Figure 8:	Buck Output Voltage Control Concept	19
Figure 9:	Resistive Divider.....	20
Figure 10:	Thermal Protection Operation	21
Figure 11:	Interrupt Operation Example	24
Figure 12:	Interrupt Operation Example 2	25
Figure 13:	Interrupt Operation Example 3	25
Figure 14:	Interrupt Operation Example 4	25
Figure 15:	Power-Good (PG) and System Good (SG)	27
Figure 16:	I ² C START and STOP Condition Timing.....	30
Figure 17:	I ² C Byte Write (SDA Line)	30
Figure 18:	I ² C Byte Read (SDA Line) Examples	30
Figure 19:	Package Outline Drawing.....	52

Table of Tables

Table 1:	Pin Description	8
Table 2:	Pin Type Definition	9
Table 3:	Absolute Maximum Ratings.....	10
Table 4:	Recommended Operating Conditions	10
Table 5:	Package Ratings	11
Table 6:	Power Dissipation	11
Table 7:	ESD Characteristics	11
Table 8:	Buck Electrical Characteristics	12
Table 9:	Electrical Characteristics	14
Table 10:	Digital I/O Electrical Characteristics	15
Table 11:	I ² C Electrical Characteristics	16
Table 12:	Thermal Protection Control Registers	21
Table 13:	Interrupt List.....	22
Table 14:	Interrupt Registers Except for Power-Good Status	23
Table 15:	Interrupt Registers for Power-Good, System Good, and Temp Warning Status	23
Table 16:	GPIO Pin Assignment	26
Table 17:	GPIO Function Configuration	26
Table 18:	GPIO0-Configurable Registers when CONF_EN = 1	28
Table 19:	Register Map	31
Table 20:	SYS_STATUS_0 (0x0001).....	33

High-Performance, Dual-Channel DC-DC Converter for Mobile and Portable Applications

Table 21: SYS_STATUS_1 (0x0002)	33
Table 22: SYS_STATUS_2 (0x0003)	33
Table 23: SYS_EVENT_0 (0x0004)	33
Table 24: SYS_EVENT_1 (0x0005)	33
Table 25: SYS_EVENT_2 (0x0006)	34
Table 26: SYS_MASK_0 (0x0007)	34
Table 27: SYS_MASK_1 (0x0008)	34
Table 28: SYS_MASK_2 (0x0009)	34
Table 29: SYS_MASK_3 (0x000A)	35
Table 30: SYS_CONFIG_0 (0x000B)	35
Table 31: SYS_CONFIG_1 (0x000C)	36
Table 32: SYS_CONFIG_2 (0x000D)	37
Table 33: SYS_CONFIG_3 (0x000E)	37
Table 34: SYS_GPIO0_0 (0x0010)	38
Table 35: SYS_GPIO0_1 (0x0011)	39
Table 36: SYS_GPIO1_0 (0x0012)	39
Table 37: SYS_GPIO1_1 (0x0013)	40
Table 38: SYS_GPIO2_0 (0x0014)	41
Table 39: SYS_GPIO2_1 (0x0015)	41
Table 40: BUCK_BUCK1_0 (0x0020)	43
Table 41: BUCK_BUCK1_1 (0x0021)	43
Table 42: BUCK_BUCK1_2 (0x0022)	44
Table 43: BUCK_BUCK1_3 (0x0023)	44
Table 44: BUCK_BUCK1_4 (0x0024)	45
Table 45: BUCK_BUCK1_5 (0x0025)	45
Table 46: BUCK_BUCK1_6 (0x0026)	46
Table 47: BUCK_BUCK1_7 (0x0027)	46
Table 48: BUCK_BUCK2_0 (0x0028)	47
Table 49: BUCK_BUCK2_1 (0x0029)	47
Table 50: BUCK_BUCK2_2 (0x002A)	48
Table 51: BUCK_BUCK2_3 (0x002B)	48
Table 52: BUCK_BUCK2_4 (0x002C)	49
Table 53: BUCK_BUCK2_5 (0x002D)	49
Table 54: BUCK_BUCK2_6 (0x002E)	50
Table 55: BUCK_BUCK2_7 (0x002F)	50
Table 56: OTP_DEVICE_ID (0x0048)	51
Table 57: OTP_VARIANT_ID (0x0049)	51
Table 58: OTP_CUSTOMER_ID (0x004A)	51
Table 59: OTP_CONFIG_ID (0x004B)	51
Table 60: MSL Classification	53
Table 61: Ordering Information	54
Table 62: Recommended Consumer Grade Capacitor Types	55
Table 63: Recommended Automotive Grade Capacitor Types	55
Table 64: Recommended Inductor Types	55

High-Performance, Dual-Channel DC-DC Converter for Mobile and Portable Applications

1 Terms and Definitions

ATE	Automated test equipment
CPU	Central processing unit
DDR	Dual data rate
DVC	Dynamic voltage control
FET	Field effect transistor
FM+	Fast mode plus
GBD	Guaranteed by design
GBQ	Guaranteed by qualification
GBSPC	Guaranteed by statistical process characterization
GPI	General purpose input
GPIO	General purpose input/output
GPU	Graphics processing unit
IC	Integrated circuit
HW	Hardware
OTP	One time programmable
PCB	Printed circuit board
PRS	Product requirements specification
SCL	Serial clock
SDA	Serial data
SIPP	Single in-line pin package
SW	Software

2 Pinout

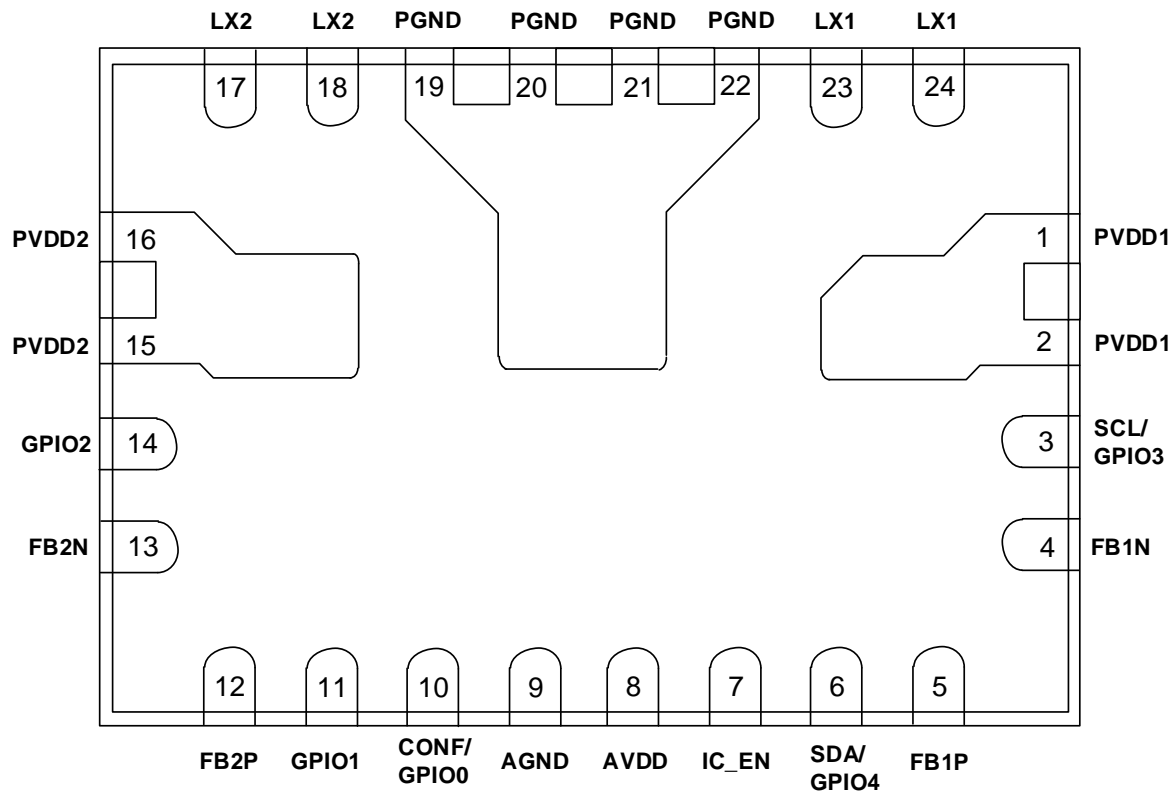

Figure 4: DA9132 Pinout Diagram (Bottom View)

Table 1: Pin Description

Pin #	Pin Name	Type (Table 2)	Drive (mA)	Description
1, 2	PVDD1	PS	5000	Supply for Ch1
3	SCL/GPIO3	DIO	15	SCL
4	FB1N	AI	10	Negative feedback for Ch1
5	FB1P	AI	10	Positive feedback for Ch1
6	SDA/GPIO4	DIO	15	SDA
7	IC_EN	DI	10	IC enable.
8	AVDD	PS	10	Analog supply
9	AGND	PS	10	Analog ground
10	GPIO0	DIO	10	GPIO
11	CONF/GPIO1	DIO	10	GPIO
12	FB2P	AI	10	Positive feedback for Ch2
13	FB2N	AI	10	Negative feedback for Ch2
14	GPIO2	DIO	10	GPIO
15, 16	PVDD2	PS	5000	Supply for Ch2
17, 18	LX2	AO	5000	Buck output of Ch2
19, 20, 21, 22	PGND	PS	5000	Power ground

High-Performance, Dual-Channel DC-DC Converter for Mobile and Portable Applications

Pin #	Pin Name	Type (Table 2)	Drive (mA)	Description
23, 24	LX1	AO	5000	Buck output of Ch1

Table 2: Pin Type Definition

Pin Type	Description	Pin Type	Description
DI	Digital input	AI	Analog input
DIO	Digital input/output	AO	Analog output
PS	Power supply		

High-Performance, Dual-Channel DC-DC Converter for Mobile and Portable Applications

3 Characteristics

3.1 Absolute Maximum Ratings

Stresses beyond those listed under Absolute Maximum Ratings may cause permanent damage to the device. These are stress ratings only, so functional operation of the device at these or any other conditions beyond those indicated in the operational sections of the specification are not implied. Exposure to Absolute Maximum Rating conditions for extended periods may affect device reliability.

Table 3: Absolute Maximum Ratings

Parameter	Description	Conditions	Min	Max	Unit
T _{STG}	Storage temperature		-65	150	°C
T _J	Junction temperature		-40	150	°C
V _{SYS}	System supply voltage		-0.3	6.0	V
V _{PIN}	Voltage on pins		-0.3	6.0	V

3.2 Recommended Operating Conditions

Table 4: Recommended Operating Conditions

Parameter	Description	Conditions (Note 1)	Min	Typ	Max	Unit
V _{SYS}	System supply voltage		2.8		5.5	V
V _{PIN}	Voltage on pins		-0.3		V _{SYS} + 0.3	V
T _J	Junction temperature		-40		125	°C
T _A	Ambient temperature		-40		105	°C

Note 1 Within the specified limits, a lifetime of 10 years is guaranteed. If operating outside of these recommended conditions, please consult with Dialog Semiconductor.

High-Performance, Dual-Channel DC-DC Converter for Mobile and Portable Applications

3.3 Thermal Characteristics

3.3.1 Thermal Ratings

Table 5: Package Ratings

Parameter	Description	Conditions	Min	Typ	Max	Unit
θ_{JA}	Package thermal resistance			21.21 Note 1		°C/W

Note 1 Obtained from package thermal simulations, JEDEC 2S2P four layer board (76.2 mm x 114 mm x 1.6 mm), 70 μm (2 oz) copper thickness power planes, 35 μm (1 oz) copper thickness signal layer traces, natural convection (still air), see Section 6.1.

3.3.2 Power Dissipation

Table 6: Power Dissipation

Parameter	Description	Conditions	Min	Typ	Max	Unit
P_{D_Twarn}	Power dissipation	@ 105 °C ambient, T_{J_WARN}		0.94		W
P_{D_Tcrit}	Power dissipation	@ 105 °C ambient, T_{CRIT}		1.65		W

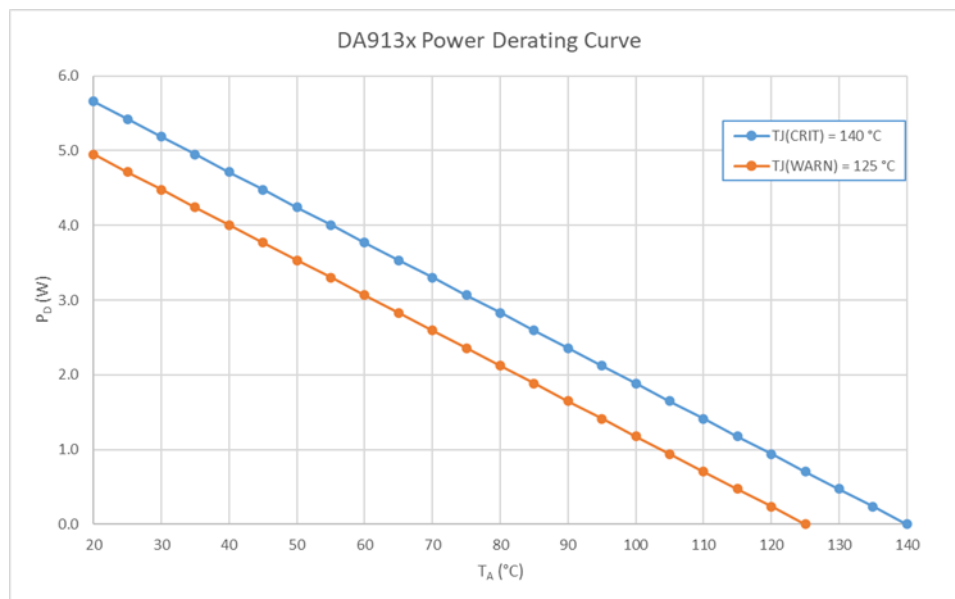

Figure 5: Power Derating Curve

3.4 ESD Characteristics

Table 7: ESD Characteristics

Parameter	Description	Conditions	Min	Typ	Max	Unit
V_{ESD_HBM}	ESD protection, human body model (HBM)				2	kV

High-Performance, Dual-Channel DC-DC Converter for Mobile and Portable Applications

3.5 Buck Characteristics

Unless otherwise noted, the following is valid for $T_J = -40\text{ }^{\circ}\text{C}$ to $+125\text{ }^{\circ}\text{C}$, $V_{SYS} = 2.8\text{ V}$ to 5.5 V .

Table 8: Buck Electrical Characteristics

Parameter	Description	Conditions	Min	Typ	Max	Unit
External Electrical Conditions						
V_{IN}	Input voltage	$V_{IN} = V_{SYS}$	2.8		5.5	V
C_{OUT}	Output capacitance, including voltage and temperature coefficient		-40 %	20	+30 %	μF
ESR_{COUT}	Output capacitor series resistance	$f > 100\text{ kHz}$		1		$\text{m}\Omega$
L	Inductor value, including current and temperature dependence		-50 %	220	+20 %	nH
DCR_L	Inductor DC resistance			8	13	$\text{m}\Omega$
Electrical Performance						
V_{OUT}	Output voltage, programmable in 10 mV steps	$I_{OUT} = 0\text{ mA}$ to I_{MAX} at $25\text{ }^{\circ}\text{C}$ ambient $2.8\text{ V} < V_{OUT} + 1\text{ V} < V_{IN} \leq 5.5\text{ V}$	0.3		1.9	V
I_{LIM}	Current limit, programmable per phase Note 1	$CHx_ILIM = 0100$	-20 %	5	+20 %	A
I_{MAX}	Output current Note 2	$A_{VDD} \geq V_{OUT} + 1.0\text{ V}$	3			A
V_{OUT_ACC}	Output voltage accuracy, including static line and load regulation	$V_{OUT} < 1\text{ V}$	-10		10	mV
V_{OUT_ACC}	Output voltage accuracy, including static line and load regulation	$V_{OUT} \geq 1\text{ V}$	-1		1	%
$V_{THR_PG_HYS}$	Power-good voltage threshold hysteresis	Referred to $V_{THR_PG_DWN}$	60	80	100	mV
$V_{THR_PG_DWN}$	Power-good voltage threshold for falling	Referred to V_{OUT}	-160	-130	-80	mV
V_{THR_HV}	High V_{OUT} voltage threshold	Referred to V_{OUT}	100	150	200	mV
$V_{OUT_TR_LINE}$	Line transient response	$V_{IN} = 3\text{ V}$ to 3.6 V $I_{OUT} = 0.5 * I_{MAX}$ $dt = 10\text{ }\mu\text{s}$		15		mV
f_{SW}	Switching frequency			4		MHz

High-Performance, Dual-Channel DC-DC Converter for Mobile and Portable Applications

Parameter	Description	Conditions	Min	Typ	Max	Unit
t_{ON_MIN}	Minimum turn-on pulse 0 % duty is also supported		5	7	11	ns
t_{BUCK_EN}	Turn-on time	CH _X _EN = high			20	μs
R _{PD}	Output pull-down resistance at the LX node, see CH _X _PD_DIS	V _{IN} = 3.7 V V _{OUT} = 0.5 V	145	150	161	Ω
R _{ON_PMOS}	On resistance of switching PMOS	V _{IN} = 3.7 V	17	25	37	mΩ
R _{ON_NMOS}	On resistance of switching NMOS	V _{IN} = 3.7 V	6	10	16	mΩ
PWM Mode						
I _{Q_PWM}	Quiescent current	V _{IN} = 3.7 V No load		16		mA
η _{PWM}	Efficiency	V _{IN} = 3.6 V V _{OUT} = 1 V I _{OUT} = 10 % (I _{MAX}) to 80 % (I _{MAX})		85		%
AUTO Mode						
V _{OUT_TR_LD}	Load transient response	V _{OUT} = 1 V I _{OUT} = 0 to 5 A at 25 °C ambient dI/dt = 10 A/μs	-40		80	mV
PFM Mode						
I _{Q_PFM}	Quiescent current in PFM	1-phase V _{IN} = 3.7 V No load No switching		88		μA
η _{PFM}	Efficiency	V _{IN} = 3.6 V V _{OUT} = 1 V I _{OUT} = 10 mA		80		%

Note 1 $t_{ON} > 40$ ns

Note 2 For short durations to meet peak current requirements, I_{OUT} can be operated at up to 10 % higher than the specified maximum operating condition. The part should not be operated in this mode for extended periods and is not guaranteed for continuous operation.

High-Performance, Dual-Channel DC-DC Converter for Mobile and Portable Applications

3.6 Performance and Supervision Characteristics

Table 9: Electrical Characteristics

Parameter	Description	Conditions	Min	Typ	Max	Unit
Electrical Performance						
V _{THR_POR}	Power-on-reset threshold	Threshold for AVDD falling		2.1	2.25	V
V _{THR_POR_HYS}	Power-on-reset hysteresis			200		mV
T _{WARN}	Thermal warning temperature threshold		115	125	135	°C
T _{CRIT}	Thermal shutdown temperature threshold		130	140	150	°C
I _{IN_OFF}	Supply current	OFF state T _A = 27 °C IC_EN = 0		0.1	1	μA
I _{IN_ON}	Supply current	ON state T _A = 27 °C IC_EN = 1 Buck off	5	10	20	μA

High-Performance, Dual-Channel DC-DC Converter for Mobile and Portable Applications

3.7 Digital I/O Characteristics

Table 10: Digital I/O Electrical Characteristics

Parameter	Description	Conditions	Min	Typ	Max	Unit
Electrical Performance						
V _{IH_EN}	Input high voltage, IC enable		1.2		AVDD	V
V _{IL_EN}	Input low voltage, IC enable				0.4	V
t _{IC_EN}	IC enable time				1000	μs
V _{IH_GPIO_SCL_SDA}	Input high voltage GPIO, SCL, SDA		1.2		AVDD	V
V _{IL_GPIO_SCL_SDA}	Input low voltage GPIO, SCL, SDA				0.4	V
V _{OH_GPIO}	Output high voltage GPIO	Push-pull mode I _{OUT} = 1 mA	0.8*AVDD		AVDD	V
V _{OL_GPIO}	Output low voltage GPIO	Push-pull mode I _{OUT} = 1 mA			0.2*AVDD	V
V _{OL_SDA}	Output low voltage SDA	I _{OUT} = 3 mA		0.24		V
R _{PD}	GPIO pull-down resistor		10	15	23	kΩ
R _{PU}	GPIO pull-up resistor		33	46	65	kΩ

High-Performance, Dual-Channel DC-DC Converter for Mobile and Portable Applications

3.8 Timing Characteristics

Table 11: I2C Electrical Characteristics

Parameter	Description	Conditions	Min	Typ	Max	Unit
Electrical Performance						
t _{BUS}	Bus free time between a STOP and START condition		0.5			μs
C _{BUS}	Bus line capacitive load				150	pF
f _{SCL}	SCL clock frequency		20 Note 1		1000	kHz
t _{LO_SCL}	SCL low time		0.5			μs
t _{HI_SCL}	SCL high time		0.26			μs
t _{RISE}	SCL and SDA rise time	Requirement for input			1000	ns
t _{FALL}	SCL and SDA fall time	Requirement for input			300	ns
t _{SETUP_START}	Start condition setup time		0.26			μs
t _{HOLD_START}	Start condition hold time		0.26			μs
t _{SETUP_STOP}	Stop condition setup time		0.26			μs
t _{DATA}	Data valid time				0.45	μs
t _{DATA_ACK}	Data valid acknowledge time				0.45	μs
t _{SETUP_DATA}	Data setup time		50			ns
t _{HOLD_DATA}	Data hold time		0			ns

Note 1 Minimum clock frequency is limited to 20 kHz if I2C_TIMEOUT is enabled

High-Performance, Dual-Channel DC-DC Converter for Mobile and Portable Applications

3.9 Typical Performance

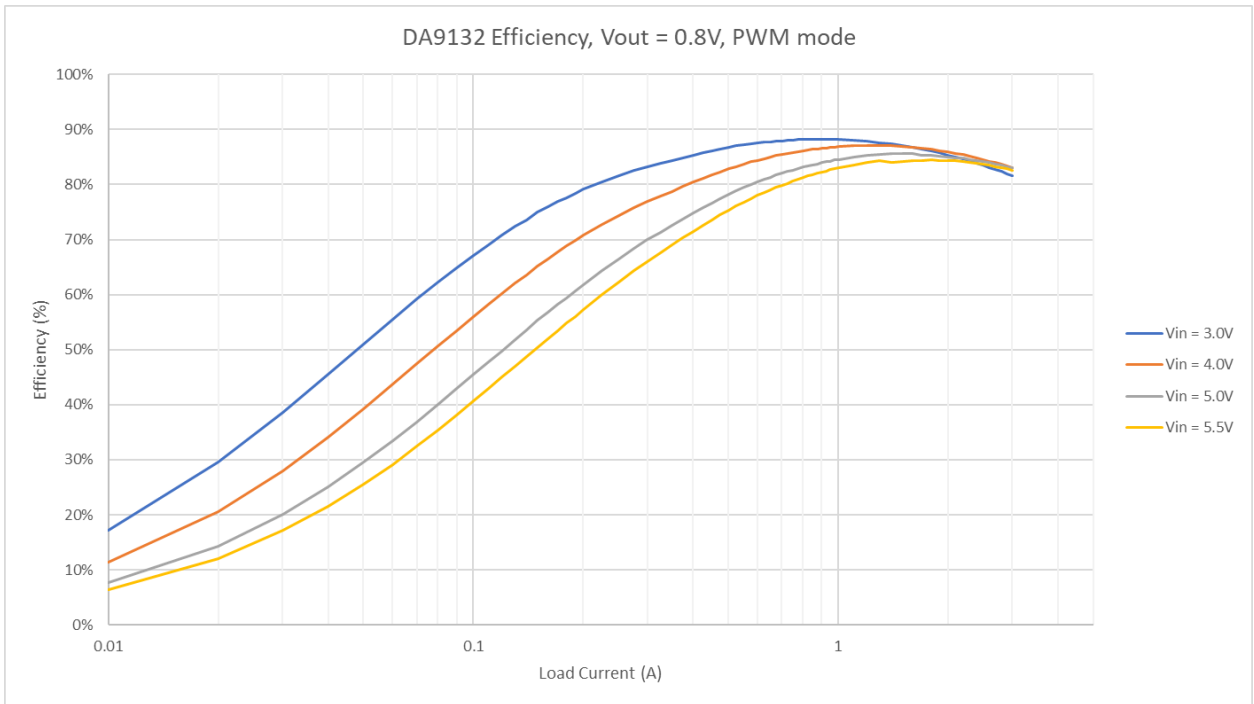

Figure 6: DA9132 Efficiency, $V_{OUT} = 0.8 V$, PWM Mode

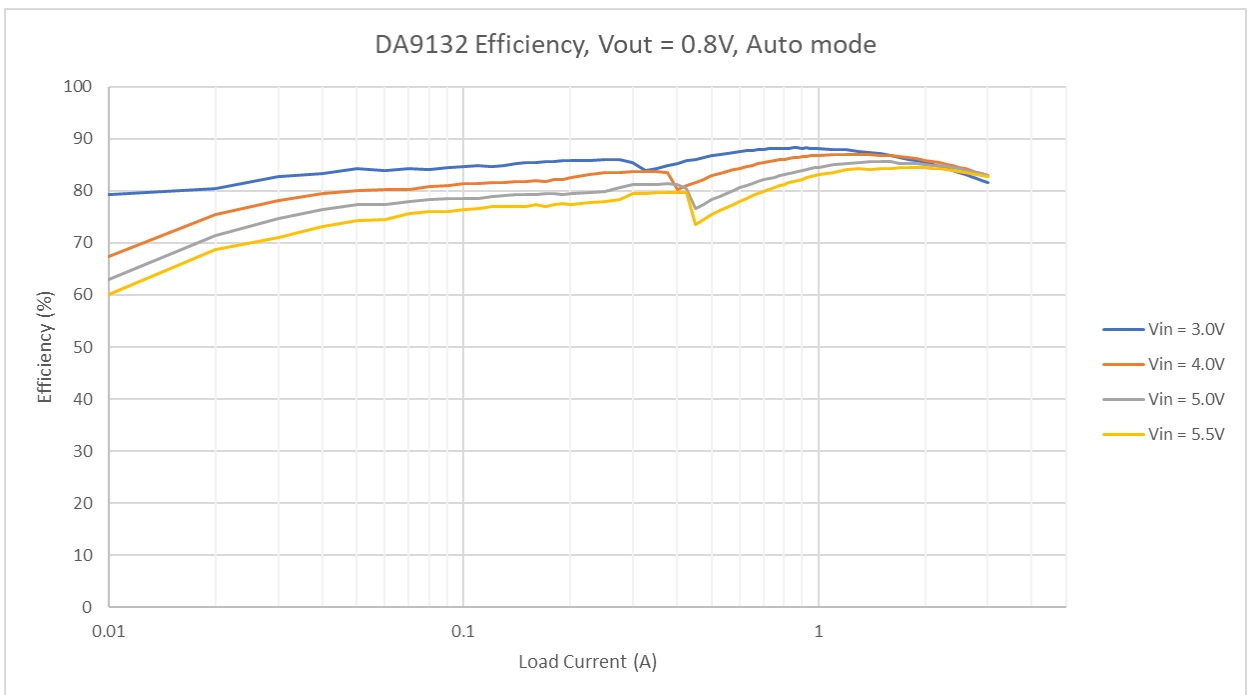

Figure 7: DA9132 Efficiency, $V_{OUT} = 0.8 V$, Auto Mode

High-Performance, Dual-Channel DC-DC Converter for Mobile and Portable Applications

4 Functional Description

4.1 DC-DC Buck Converter

DA9132 contains two buck converters, Buck1 and Buck2, each capable of delivering up to 3 A output current at a 0.3 V to 1.9 V output voltage range.

Buck1 and Buck2 have two voltage registers each. One defines the normal output voltage, while the other offers an alternative retention voltage. In this way, different application power modes can easily be supported. The voltage selection can be operated either via GPI or via control interface to guarantee the maximum flexibility according to the specific host processor status in the application.

When a buck is enabled, its output voltage is monitored and a power-good signal indicates that the buck output voltage has reached a level higher than the $V_{THR_PG_HYS}$ threshold. The power-good status is lost when the voltage drops below $V_{THR_PG_DWN}$ or increases above V_{THR_HV} . For each of the buck converters the status of the power-good indicator can be read back via I²C from the PG1 and PG2 status bits. It can be also individually assigned to any of the GPIOs by setting the GPIO mode registers to either PG1 or PG2 output.

The buck converters are capable of supporting DVC transitions that occur when:

- the active and selected A- or B-voltage is updated to a new target value
- the voltage selection is changed from the A- to B-voltage (or B- to A-voltage) using CH<x>_VSEL

The DVC controller operates in pulse width modulation (PWM) mode with synchronous rectification.

The slew rate of the DVC transition is individually programmed for each buck converter at 10 mV per 8 μ s, 4 μ s, 2 μ s, 1 μ s, or 0.5 μ s in register bits CH1_SR_DVC and CH2_SR_DVC.

A pull-down resistor (typically 150 Ω) for each phase is always activated unless it is disabled by setting register bits CH<x>_PD_DIS to 1.

4.1.1 Switching Frequency

The buck switching frequency can be tuned using register bit OSC_TUNE. The internal 8 MHz oscillator frequency is tuned in ± 160 kHz steps. This impacts the buck converter frequency in steps of 80 kHz and helps to mitigate possible disturbances to other high frequency systems in the application.

4.1.2 Operation Modes and Phase Selection

The buck converters can operate in PWM and PFM modes. The operating mode is selected using register bits CH1_<A or B>_MODE and CH2_<A or B>_MODE.

If the automatic operation mode is selected on CH1_<A or B>_MODE or CH2_<A or B>_MODE, the buck converters automatically change between synchronous PWM mode and PFM depending on the load current. This improves the efficiency across the whole range of output load currents.

High-Performance, Dual-Channel DC-DC Converter for Mobile and Portable Applications

4.1.3 Output Voltage Selection

The switching converter can be configured using the I²C interface.

For each buck converter two output voltages can be pre-configured in registers CH<x>_<A or B>_VOUT. The output voltage can be selected by either toggling register bit CH<x>_VSEL or by re-programming the selected voltage control register. Both changes will result in ramped voltage transitions. After being enabled, the buck converter will, by default, use the register settings in CH<x>_A_VOUT unless the output voltage selection is configured via the GPI port.

Registers CH<1 and 2>_VMAX limit the output voltage that can be set for each of the respective buck converters.

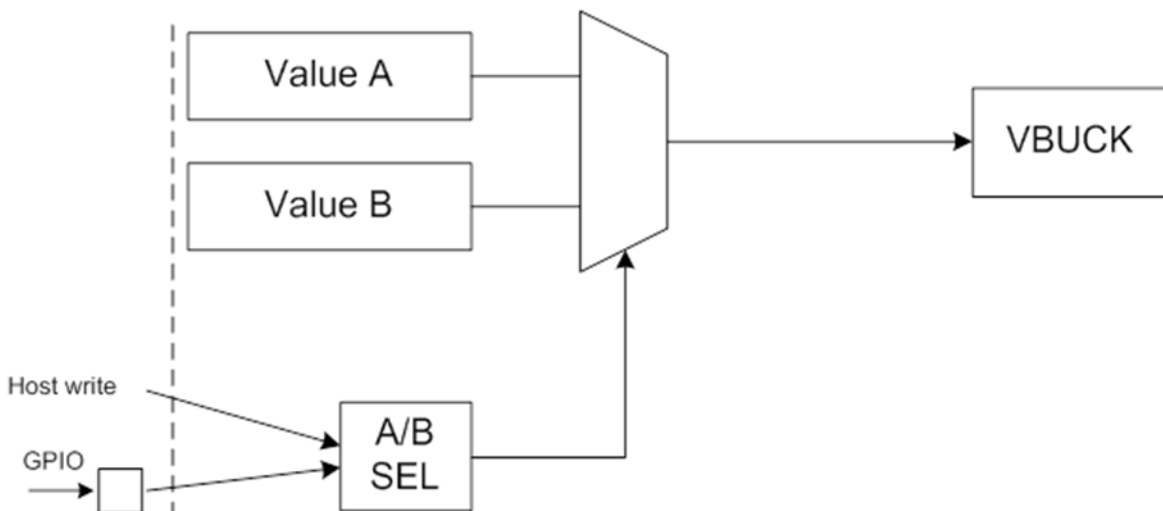

Figure 8: Buck Output Voltage Control Concept

4.1.4 Soft Start-Up and Shutdown

To limit in-rush current from VSYS, the buck converters can perform a soft-start after being enabled. The start-up behavior is a compromise between acceptable inrush current from the battery and turn-on time. Individual ramp times can be configured for each buck converter in registers CH<1 and 2>_SR_STARTUP respectively. Rates higher than 20 mV/μs may produce overshoot during the start-up phase, so they should be considered carefully.

A ramped power down can be selected in register bits CH<1 and 2>_SR_SHDN. When no ramp is selected (immediate power down), the output node will be discharged only by the pull-down resistor, if enabled in registers CH<1 and 2>_PD_DIS.

4.1.5 Current Limit

The integrated current limit protects the power stages and external coil from excessive current. The buck current limit should be configured to at least 40 % higher than the required maximum output current.

When the current limit is reached, each buck converter generates an event and an interrupt to the host processor unless the interrupt has been masked using register M_OC<x> in SYS_MASK_1. Register bits OC_DVC_MASK is used to mask over-current events during DVC transitions.

High-Performance, Dual-Channel DC-DC Converter for Mobile and Portable Applications

4.1.6 Resistive Divider

DA9132 can support output voltages higher than 1.9 V using an external resistive divider shown in Figure 9.

To calculate the output voltage with an external divider, use the following equation

$$V_{OUT} = V_{SEL} \times \left(1 + \frac{R1}{R2}\right)$$

Equation 1

V_{SEL} is the device buck output voltage setting.

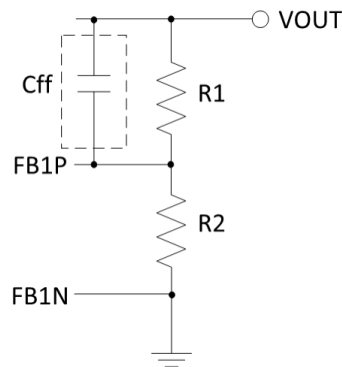

Figure 9: Resistive Divider

For example, to program the output voltage to 3.3 V, set V_{SEL} to 1.65 V, and use a 2.2 kΩ resistor for both R1 and R2, with C_{ff} = 1 nF.

NOTE

The resistors need to be properly selected since the output voltage accuracy will be directly affected by any errors on the resistors. The voltage across FB1P and FB1N (V_{SEL}) is guaranteed, but not the output voltage accuracy.

CAUTION

- The followings are important notes that need to be considered before using resistive divider on DA9132:
1. Please contact your region's Dialog representative when adopting the resistive divider technique. Dialog need to prepare a special OTP because incorrect OTP settings may result in a different output voltage than expected.
 2. The total resistance (R1+R2) is less than 40 kΩ.
 3. It is recommended that the device is operated in PWM mode only.

High-Performance, Dual-Channel DC-DC Converter for Mobile and Portable Applications

4.1.7 Thermal Protection

DA9132 is protected from internal overheating by thermal shutdown.

There are two kinds of flags concerning thermal protection, thermal warning and thermal critical. The warning flag is asserted when $T_J > T_{WARN}$ and the critical flag is asserted when $T_J > T_{CRIT}$. When the critical flag is asserted, Buck1 and Buck2 are shut down immediately.

Table 12: Thermal Protection Control Registers

Category	Register name	Description
Status	TEMP_WARN	Asserted as long as the thermal warning threshold is reached
	TEMP_CRIT	Asserted as long as the thermal shutdown threshold is reached
IRQ event	E_TEMP_WARN	TEMP_WARN caused event
	E_TEMP_CRIT	TEMP_CRIT caused event
IRQ mask	M_TEMP_WARN	TEMP_WARN event IRQ mask
	M_TEMP_CRIT	TEMP_CRIT event IRQ mask
	M_VR_HOT	TEMP_WARN status IRQ mask

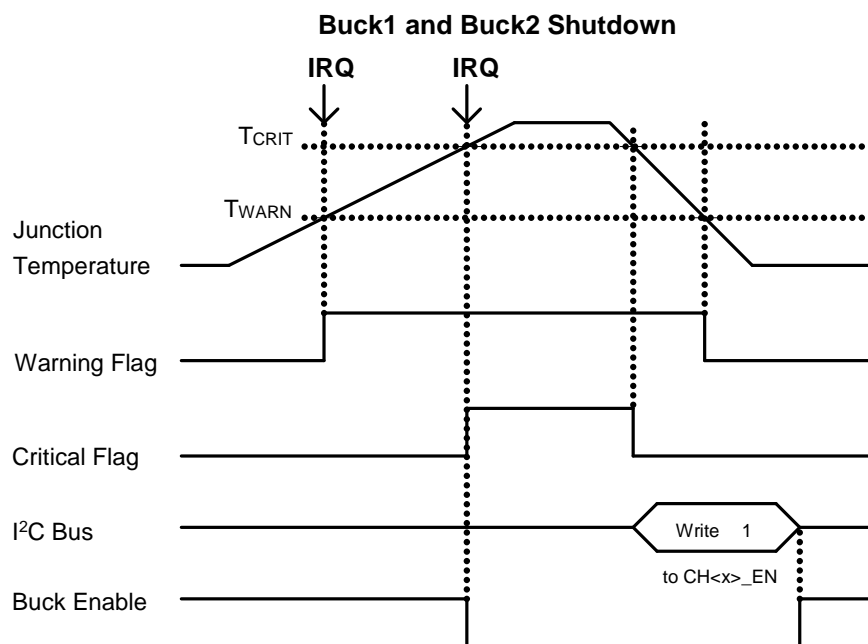

Figure 10: Thermal Protection Operation

4.2 Internal Circuits

4.2.1 IC_EN/Chip Enable/Disable

IC_EN is chip enable/disable control input. When IC_EN = 0, all blocks except for low I_q POR are powered-down and buck output is pulled-down.

4.2.2 nIRQ/Interrupt

The interrupt triggers events. Trigger conditions and control registers for each interrupt event are listed in [Table 13](#).

High-Performance, Dual-Channel DC-DC Converter for Mobile and Portable Applications

Some of these events are categorized as fault events and affect device operation (for example, buck disable), see Section 4.1.6.

Table 13: Interrupt List

Name	Polarity (Note 1)	Trigger	IRQ Status Register	IRQ Mask Register	Deglitch Period
Thermal warning (event)	N	T_J rising above T_{WARN}	E_TEMP_WARN	M_TEMP_WARN	0 s
Thermal critical (event)	N	T_J rising above T_{CRIT}	E_TEMP_CRIT	M_TEMP_CRIT	0 s
System good (event)	P		E_SG	M_SG	0 s
Buck1 power-good (event)	P	Buck1 V_{OUT} is in power-good voltage range (not under- or over-voltage)	E_PG1	M_PG1	0 s
Buck2 power-good (event)	P	Buck2 V_{OUT} is in power-good voltage range (not under- or over-voltage)	E_PG2	M_PG2	0 s
Buck1 over-voltage (event)	N	Buck1 V_{OUT} rising above over-voltage threshold (target voltage + 150 mV)	E_OV1	M_OV1	Rise:8 μ s Fall:8 μ s
Buck2 over-voltage (event)	N	Buck2 V_{OUT} rising above over-voltage threshold (target voltage + 150 mV)	E_OV2	M_OV2	Rise:8 μ s Fall:8 μ s
Buck1 under-voltage (event)	N	Buck1 V_{OUT} falling below under-voltage threshold (target voltage - V_{TH_PG})	E_UV1	M_UV1	0 s
Buck2 under-voltage (event)	N	Buck2 V_{OUT} falling below under-voltage threshold (target voltage - V_{TH_PG})	E_UV2	M_UV2	0 s
Buck1 over-current (event)	N	Buck1 current rising above over-current threshold	E_OC1	M_OC1	0 s
Buck2 over-current (event)	N	Buck2 current rising above over-current threshold	E_OC2	M_OC2	0 s
Buck1 power-good (status) (Note 2)	P	Buck1 V_{OUT} is in power-good voltage range (not under- or over-voltage)	PG1	M_PG1_STAT (Note 3)	0 s
Buck2 power-good (status) (Note 2)	P	Buck2 V_{OUT} is in power-good voltage range (not under- or over-voltage)	PG2	M_PG2_STAT (Note 3)	0 s

High-Performance, Dual-Channel DC-DC Converter for Mobile and Portable Applications

Name	Polarity (Note 1)	Trigger	IRQ Status Register	IRQ Mask Register	Deglintch Period
System good (status) (Note 2)	P		SG	M_SG_STAT (Note 3)	0 s
Thermal warning (status) (Note 2)	N	T _J rising above T _{WARN}	TEMP_WARN	M_VR_HOT (Note 3)	0 s
GPIO0 change (event)	N	Detect GPIO0 change for active trigger selected GPIO0_TRIG register	E_GPIO0	M_GPIO0	100 μs/ 1 ms/ 10 ms/ 100 ms
GPIO1 change (event)	N	Detect GPIO1 change for active trigger selected GPIO1_TRIG register	E_GPIO1	M_GPIO1	
GPIO2 change (event)	N	Detect GPIO2 change for active trigger selected GPIO2_TRIG register	E_GPIO2	M_GPIO2	

Note 1 Polarity at the source of the flag: P = active-high, N = active-low.
General rule is: normal system state is high, and abnormal system state is low (for example, PG = high means power-good, TEMP_CRIT = low when TEMP critical state).

Note 2 Interrupt outputs the status as is. I²C write is not required for interrupt clear.

Note 3 OTP load value defined by CONF pin setting if CONF_EN = 1.

Table 14: Interrupt Registers Except for Power-Good Status

Register	Description
E_<name>	Read-only interrupt event register 0: No interrupt 1: Interrupt occurred Cleared after being written to I²C. Set until IRQ is removed.
M_<name>	Interrupt mask register 0: Not masked 1: Masked. No IRQ signal sent. Event register (E_<name>) is updated.

Table 15: Interrupt Registers for Power-Good, System Good, and Temp Warning Status

Register	Description
PG<x>	Buck<x> power-good status. Asserted as long as the buck<x> output voltage is in range (under-voltage threshold < buck output voltage < over-voltage threshold) 0: Not power-good 1: Power-good
M_PG<x>_STAT	Power-good status interrupt mask register 0: Not masked 1: Masked. No IRQ signal sent. Power-good status register (PG<x>) is updated
SG	System good status 0: Not system good

High-Performance, Dual-Channel DC-DC Converter for Mobile and Portable Applications

Register	Description
	1: System good
M_SG_STAT	System good status (SG) interrupt mask register 0: Not masked 1: Masked. No IRQ signal sent. System good status register (SG) is updated
TEMP_WARN	Asserted as long as the thermal warning threshold (T_{WARN}) is reached 0: Junction temperature is below T_{WARN} 1: Junction temperature is above T_{WARN}
M_VR_HOT	Temperature warning status (TEMP_WARN) interrupt mask register 0: Not masked 1: Masked. No IRQ signal sent. Temperature warning status register (TEMP_WARN) is updated

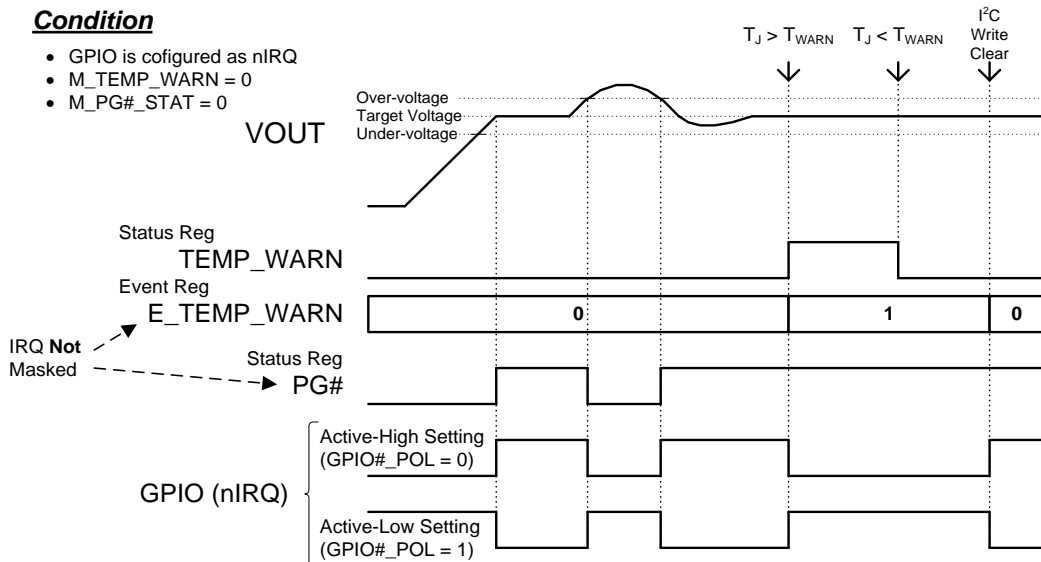

Figure 11: Interrupt Operation Example

High-Performance, Dual-Channel DC-DC Converter for Mobile and Portable Applications

Condition

- GPIO is configured as nIRQ
- M_VR_HOT = 0
- M_PG1_STAT = 0
- M_PG2_STAT = 0

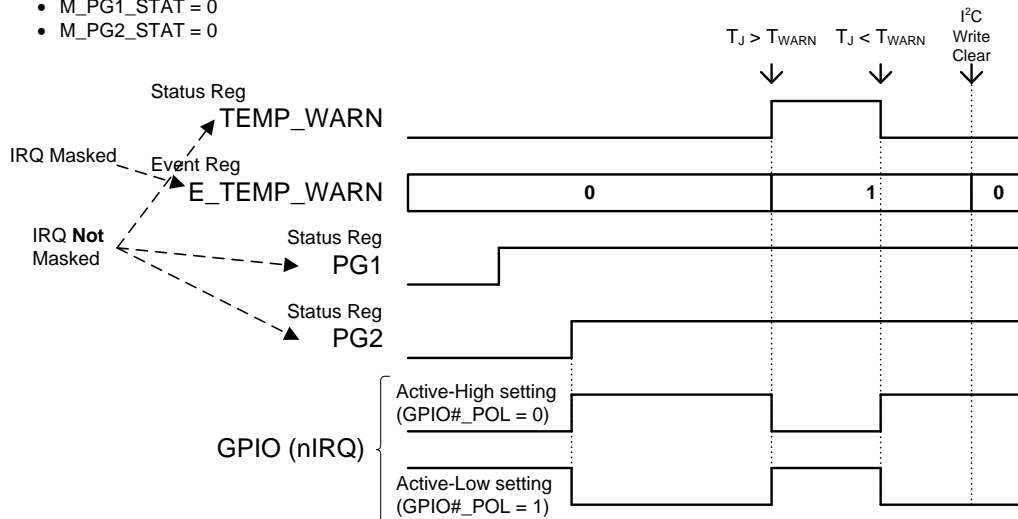

Figure 12: Interrupt Operation Example 2

Condition

- GPIO is configured as nIRQ
- M_SG = 0

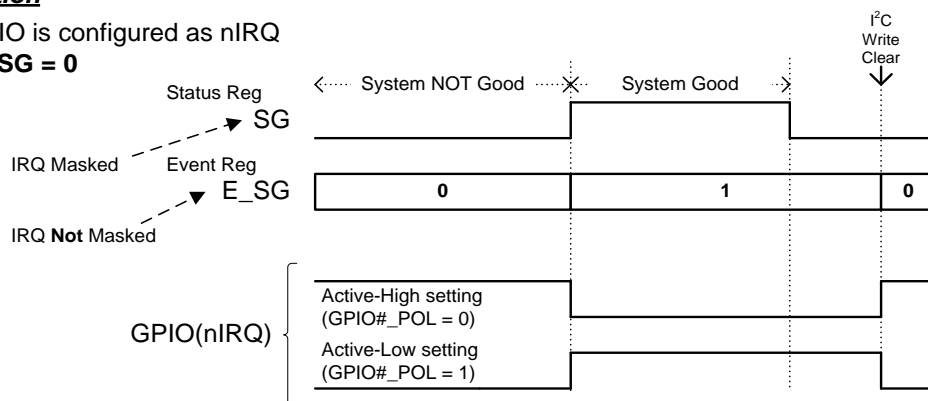

Figure 13: Interrupt Operation Example 3

Condition

- GPIO is configured as nIRQ
- M_SG_STAT = 0

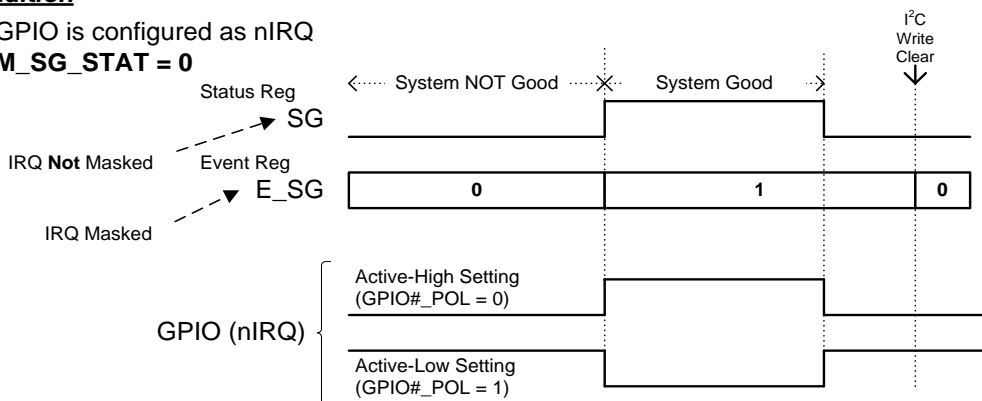

Figure 14: Interrupt Operation Example 4

High-Performance, Dual-Channel DC-DC Converter for Mobile and Portable Applications

4.2.3 GPIO

4.2.3.1 GPIO Pin Assignment

The DA9132 provides up to five GPIO pins, three if the I²C is enabled, see [Table 16](#). These registers are OTP programmable. When CONF_EN = 1 GPIO0 can be used for chip configuration.

Any register settings for GPIO3 and GPIO4 are ignored and GPIO3 and GPIO4 function as SCL and SDA respectively if I2C_EN = 1.

Table 16: GPIO Pin Assignment

OTP Option		GPIO Pin					Available GPIOs
I2C_EN	CONF_EN	CONF/ GPIO0	GPIO1	GPIO2	SCL/ GPIO3	SDA/ GPIO4	
1'b0	1'b0	GPIO0	GPIO1	GPIO2	GPIO3	GPIO4	5
	1'b1	CONF	GPIO1	GPIO2	GPIO3	GPIO4	4
1'b1	1'b0	GPIO0	GPIO1	GPIO2	SCL	SDA	3
	1'b1	CONF	GPIO1	GPIO2	SCL	SDA	2

4.2.3.2 GPIO Function

The GPIOs pins are configurable as the following functions in register GPIO<x>_MODE (x = 0 to 4):

- Buck1 enable input (EN1)
- Buck2 enable input (EN2)
- Buck1 and Buck2 enable input (EN1 & EN2)
- Buck1 DVC control input (DVC1)
- Buck2 DVC control input (DVC2)
- Buck1 and Buck2 DVC control input (DVC1 & DVC2)
- Buck1 and Buck2 OTP setting reload input (RELOAD)
- Buck1 power-good output (PG1)
- Buck2 power-good output (PG2)
- Buck1 and Buck2 power-good output (PG1 & PG2)
- System good output (SG)
- Interrupt output (nIRQ)

Table 17: GPIO Function Configuration

GPIO<x>_MODE[3:0]	Function	IO Condition
4'h0	GPIO disable	HiZ
4'h1	EN1	In
4'h2	EN2	In
4'h3	EN1 & EN2	In
4'h4	DVC1	In
4'h5	DVC2	In
4'h6	DVC1 & DVC2	In
4'h7	RELOAD	In
4'h8	PG1	Out
4'h9	PG2	Out

High-Performance, Dual-Channel DC-DC Converter for Mobile and Portable Applications

GPIO<x>_MODE[3:0]	Function	IO Condition
4'hA	PG1 & PG2	Out
4'hB	SG	Out
4'hC	nIRQ	Out
4'hD	Reserved	HiZ
4'hE	Low level	Out
4'hF	High level	Out

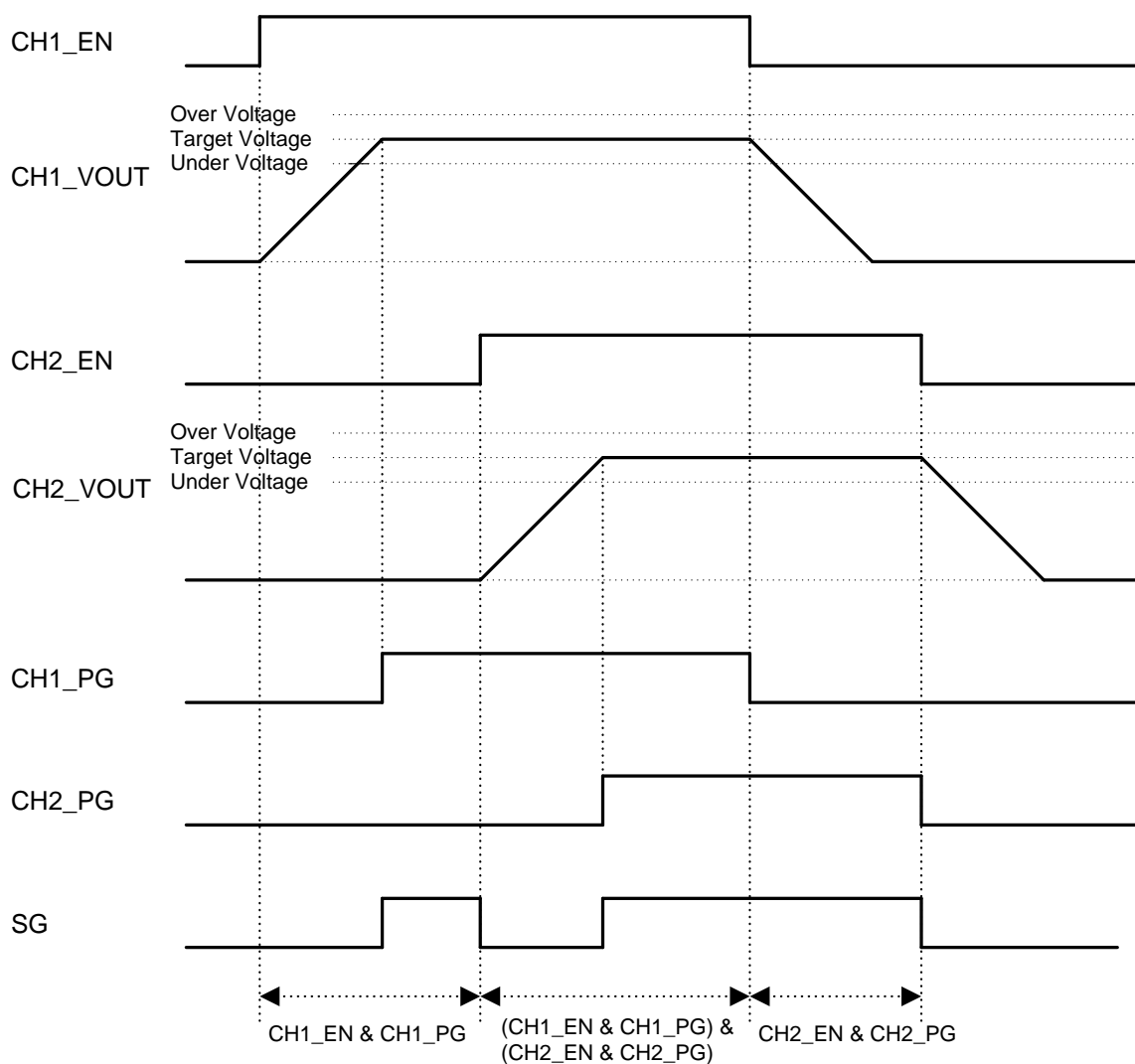

Figure 15: Power-Good (PG) and System Good (SG)

High-Performance, Dual-Channel DC-DC Converter for Mobile and Portable Applications

4.2.3.3 Chip Configuration Select (CONF)

GPIO0 functions as chip configuration select (CONF) input when CONF_EN = 1.

Three different chip configurations can be selected according to the CONF pin level, whether it is HIGH, LOW, or Hi-Z. [Table 18](#) lists the device configurations can be modified if CONF_EN = 1.

Table 18: GPIO0-Configurable Registers when CONF_EN = 1

Register Name	Description
IF_SLAVE_ADDR[6:0]	I ² C slave address
CH1_A_MODE[1:0]	CH1_A Operation mode select
CH1_B_MODE[1:0]	CH1_B Operation mode select
CH1_VSEL	CH1 output voltage and operation selection
CH1_EN	CH1 enable
CH1_A_VOUT[7:0]	CH1 output voltage setting A
CH1_B_VOUT[7:0]	CH1 output voltage setting B
CH2_A_MODE[1:0]	CH2_A Operation mode select
CH2_B_MODE[1:0]	CH2_B Operation mode select
CH2_VSEL	CH2 output voltage and operation selection
CH2_EN	CH2 enable
CH2_A_VOUT[7:0]	CH2 output voltage setting A
CH2_B_VOUT[7:0]	CH2 output voltage setting B
M_PG1_STAT	IRQ mask setting for CH1 power-good status
M_PG2_STAT	IRQ mask setting for CH2 power-good status
M_SG_STAT	IRQ mask setting for system good status
M_VR_HOT	IRQ mask setting for temp warning status
CH1_EN_DLY[3:0]	Delay setting for CH1 enable
CH1_DIS_DLY[3:0]	Delay setting for CH1 disable
CH2_EN_DLY[3:0]	Delay setting for CH2 enable
CH2_DIS_DLY[3:0]	Delay setting for CH2 disable
GPIO1_MODE[3:0]	GPIO1 mode setting
GPIO2_MODE[3:0]	GPIO2 mode setting
GPIO1_OBUF	GPIO1 output buffer select
GPIO2_OBUF	GPIO2 output buffer select
GPIO1_TRIG[1:0]	GPIO1 input trigger select
GPIO1_POL	GPIO1 polarity select
GPIO1_PUPD	GPIO1 pull-up/pull-down enable
GPIO1_DEB[1:0]	GPIO1 input debounce time setting
GPIO1_DEB_RISE	GPIO1 input debounce rising edge enable
GPIO1_DEB_FALL	GPIO1 input debounce falling edge enable
GPIO2_TRIG[1:0]	GPIO2 input trigger select
GPIO2_POL	GPIO2 polarity select
GPIO2_PUPD	GPIO2 pull-up/pull-down enable

High-Performance, Dual-Channel DC-DC Converter for Mobile and Portable Applications

Register Name	Description
GPIO2_DEB[1:0]	GPIO2 input debounce time setting
GPIO2_DEB_RISE	GPIO2 input debounce rising edge enable
GPIO2_DEB_FALL	GPIO2 input debounce falling edge enable

4.3 Operating Modes

4.3.1 ON

DA9132 is ON when the IC_EN port is higher than V_{IH_EN} and the supply voltage is higher than V_{THR_POR} . Once enabled, the host processor can start communicating with DA9132 using the control interface, after the t_{IC_EN} delay.

4.3.2 OFF

DA9132 is OFF when the IC_EN port is lower than V_{IL_EN} . In OFF, the bucks are always disabled and LX nodes are pulled down by (typically 150 Ω) internal pull-down resistors.

4.4 I²C Communication

All features of DA9132 can be controlled with the I²C interface which is enabled or disabled in register I2C_EN.

I2C_EN	Description
0	I ² C disable: SCL/GPIO3 and SDA/GPIO4 pins can be used as GPIO
1	I ² C enable: SCL/GPIO3 and SDA/GPIO4 pins are used as I ² C clock input and I ² C data input/output.

GPIO3 functions as the I²C clock and GPIO4 carries all the power manager bidirectional I²C data. The I²C interface is open-drain supporting multiple devices on a single line. The bus lines have to be pulled high by external pull-up resistors (2 k Ω to 20 k Ω). The standard frequency of the I²C bus is 1 MHz in fast-mode plus (FM+), 400 kHz in fast-mode, or 100 kHz in standard mode.

4.4.1 I²C Protocol

All data is transmitted across the I²C bus in eight-bit groups. To send a bit, the SDA line is driven towards the intended state while the SCL is low (a low SDA indicates a zero bit). Once the SDA has settled, the SCL line is brought high and then low. This pulse on SCL clocks the SDA bit into the receiver's shift register.

A two-byte serial protocol is used containing one byte for address and one byte data. Data and address transfer are transmitted MSB first for both read and write operations. All transmissions begin with the START condition from the master while the bus is in idle state (the bus is free). It is initiated by a high to low transition on the SDA line while the SCL is in the high state (a STOP condition is indicated by a low to high transition on the SDA line while the SCL is in the high state).

High-Performance, Dual-Channel DC-DC Converter for Mobile and Portable Applications



Figure 16: I²C START and STOP Condition Timing

The I²C bus is monitored for a valid slave address whenever the interface is enabled. It responds immediately when it receives its own slave address. The acknowledge is done by pulling the SDA line low during the following clock cycle (white blocks marked with A in Figure 17 and Figure 18).

The protocol for a register write from master to slave consists of a START condition, a slave address with read/write bit, and the eight-bit register address followed by eight bits of data, terminated by a STOP condition. DA9132 responds to all bytes with acknowledge (A), see Figure 17.

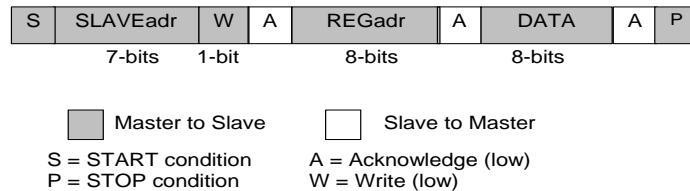

Figure 17: I²C Byte Write (SDA Line)

When the host reads data from a register it first has to write to DA9132 with the target register address and then read from DA9132 with a repeated START, or alternatively a second START, condition. After receiving the data, the host sends no acknowledge (A*) and terminates the transmission with a STOP condition, see Figure 18.

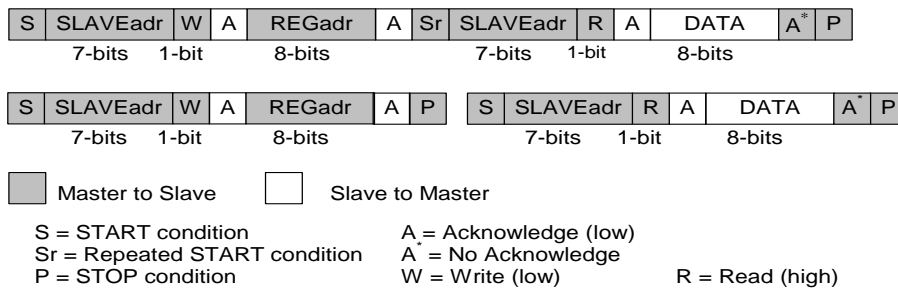

Figure 18: I²C Byte Read (SDA Line) Examples

High-Performance, Dual-Channel DC-DC Converter for Mobile and Portable Applications

5 Register Definitions

5.1 Register Map

Table 19: Register Map

Addr	Register	7	6	5	4	3	2	1	0
System Module									
System									
0x0001	SYS_STATUS_0	Reserved	Reserved	Reserved	Reserved	Reserved	SG	TEMP_CRIT	TEMP_WARN
0x0002	SYS_STATUS_1	PG2	OV2	UV2	OC2	PG1	OV1	UV1	OC1
0x0003	SYS_STATUS_2	Reserved	Reserved	Reserved	Reserved	Reserved	GPIO2	GPIO1	GPIO0
0x0004	SYS_EVENT_0	Reserved	Reserved	Reserved	Reserved	Reserved	E_SG	E_TEMP_CRIT	E_TEMP_WARN
0x0005	SYS_EVENT_1	E_PG2	E_OV2	E_UV2	E_OC2	E_PG1	E_OV1	E_UV1	E_OC1
0x0006	SYS_EVENT_2	Reserved	Reserved	Reserved	Reserved	Reserved	E_GPIO2	E_GPIO1	E_GPIO0
0x0007	SYS_MASK_0	Reserved	Reserved	Reserved	Reserved	Reserved	M_SG	M_TEMP_CRIT	M_TEMP_WARN
0x0008	SYS_MASK_1	M_PG2	M_OV2	M_UV2	M_OC2	M_PG1	M_OV1	M_UV1	M_OC1
0x0009	SYS_MASK_2	Reserved	Reserved	Reserved	Reserved	Reserved	M_GPIO2	M_GPIO1	M_GPIO0
0x000A	SYS_MASK_3	Reserved	Reserved	Reserved	Reserved	M_VR_HOT	M_SG_STAT	M_PG2_STAT	M_PG1_STAT
0x000B	SYS_CONFIG_0	CH1_DIS_DLY<3:0>				CH1_EN_DLY<3:0>			
0x000C	SYS_CONFIG_1	CH2_DIS_DLY<3:0>				CH2_EN_DLY<3:0>			
0x000D	SYS_CONFIG_2	Reserved	OC_LATCHOFF<1:0>		OC_DVC_MASK	PG_DVC_MASK<1:0>		Reserved	Reserved
0x000E	SYS_CONFIG_3	Reserved	OSC_TUNE<2:0>			Reserved	Reserved	I2C_TIMEOUT	Reserved
0x0010	SYS_GPIO0_0	Reserved	Reserved	Reserved	GPIO0_MODE<3:0>				GPIO0_OBUF
0x0011	SYS_GPIO0_1	GPIO0_DEB_FALL	GPIO0_DEB_RISE	GPIO0_DEB<1:0>		GPIO0_PUPD	GPIO0_PO L	GPIO0_TRIG<1:0>	
0x0012	SYS_GPIO1_0	Reserved	Reserved	Reserved	GPIO1_MODE<3:0>				GPIO1_OBUF
0x0013	SYS_GPIO1_1	GPIO1_DEB_FALL	GPIO1_DEB_RISE	GPIO1_DEB<1:0>		GPIO1_PUPD	GPIO1_PO L	GPIO1_TRIG<1:0>	
0x0014	SYS_GPIO2_0	Reserved	Reserved	Reserved	GPIO2_MODE<3:0>				GPIO2_OBUF
0x0015	SYS_GPIO2_1	GPIO2_DEB_FALL	GPIO2_DEB_RISE	GPIO2_DEB<1:0>		GPIO2_PUPD	GPIO2_PO L	GPIO2_TRIG<1:0>	

High-Performance, Dual-Channel DC-DC Converter for Mobile and Portable Applications

Addr	Register	7	6	5	4	3	2	1	0
Buck Control									
Buck1									
0x0020	BUCK_BUCK1_0	Reserved	CH1_SR_DVC_DWN<2:0>			CH1_SR_DVC_UP<2:0>			CH1_EN
0x0021	BUCK_BUCK1_1	Reserved	CH1_SR_SHDN<2:0>			CH1_SR_STARTUP<2:0>			CH1_PD_DIS
0x0022	BUCK_BUCK1_2	Reserved	Reserved	Reserved	Reserved	CH1_ILIM<3:0>			
0x0023	BUCK_BUCK1_3	CH1_VMAX<7:0>							
0x0024	BUCK_BUCK1_4	Reserved	Reserved	Reserved	CH1_VSE L	CH1_B_MODE<1:0>		CH1_A_MODE<1:0>	
0x0025	BUCK_BUCK1_5	CH1_A_VOUT<7:0>							
0x0026	BUCK_BUCK1_6	CH1_B_VOUT<7:0>							
0x0027	BUCK_BUCK1_7	Reserved	Reserved	Reserved	Reserved	Reserved	Reserved	CH1_RIPPLE_CANCEL<1:0>	
Buck2									
0x0028	BUCK_BUCK2_0	Reserved	CH2_SR_DVC_DWN<2:0>			CH2_SR_DVC_UP<2:0>			CH2_EN
0x0029	BUCK_BUCK2_1	Reserved	CH2_SR_SHDN<2:0>			CH2_SR_STARTUP<2:0>			CH2_PD_DIS
0x002A	BUCK_BUCK2_2	Reserved	Reserved	Reserved	Reserved	CH2_ILIM<3:0>			
0x002B	BUCK_BUCK2_3	CH2_VMAX<7:0>							
0x002C	BUCK_BUCK2_4	Reserved	Reserved	Reserved	CH2_VSE L	CH2_B_MODE<1:0>		CH2_A_MODE<1:0>	
0x002D	BUCK_BUCK1_5	CH2_A_VOUT<7:0>							
0x002E	BUCK_BUCK1_6	CH2_B_VOUT<7:0>							
0x002F	BUCK_BUCK2_7	Reserved	Reserved	Reserved	Reserved	Reserved	Reserved	CH2_RIPPLE_CANCEL<1:0>	
Serialization									
0x0048	OTP_DEVICE_ID	DEV_ID<7:0>							
0x0049	OTP_VARIANT_ID	MRC<3:0>				VRC<3:0>			
0x004A	OTP_CUSTOMER_ID	CUST_ID<7:0>							
0x004B	OTP_CONFIG_ID	CONFIG_REV<7:0>							

High-Performance, Dual-Channel DC-DC Converter for Mobile and Portable Applications

5.1.1 System

Table 20: SYS_STATUS_0 (0x0001)

Bit	Symbol	Description
[2]	SG	Asserted as long as the output voltage of the enabled buck is in range
[1]	TEMP_CRIT	Asserted whilst the thermal shutdown threshold is exceeded
[0]	TEMP_WARN	Asserted whilst the thermal warning threshold is exceeded

Table 21: SYS_STATUS_1 (0x0002)

Bit	Symbol	Description
[7]	PG2	Asserted whilst Buck2 output voltage is in range
[6]	OV2	Asserted whilst Buck2 output is over-voltage
[5]	UV2	Asserted whilst Buck2 output is under-voltage
[4]	OC2	Asserted whilst Buck2 output is over-current
[3]	PG1	Asserted whilst Buck1 output voltage is in range
[2]	OV1	Asserted whilst Buck1 output is over-voltage
[1]	UV1	Asserted whilst Buck1 output is under-voltage
[0]	OC1	Asserted whilst Buck1 output is over-current

Table 22: SYS_STATUS_2 (0x0003)

Bit	Symbol	Description
[2]	GPIO2	GPIO2 status
[1]	GPIO1	GPIO1 status
[0]	GPIO0	GPIO0 status

Table 23: SYS_EVENT_0 (0x0004)

Bit	Symbol	Description
[2]	E_SG	SG caused event. Write 1 to clear this bit after the event source has been released.
[1]	E_TEMP_CRIT	TEMP_CRIT event. Write 1 to clear this bit after the event source has been released.
[0]	E_TEMP_WARN	TEMP_WARN event. Write 1 to clear this bit after the event source has been released.

Table 24: SYS_EVENT_1 (0x0005)

Bit	Symbol	Description
[7]	E_PG2	PG2 caused event. Write 1 to clear this bit after the event source has been released.
[6]	E_OV2	OV2 caused event. Write 1 to clear this bit after the event source has been released.
[5]	E_UV2	UV2 caused event. Write 1 to clear this bit after the event source has been released.
[4]	E_OC2	OC2 caused event. Write 1 to clear this bit after the event source has been released.

High-Performance, Dual-Channel DC-DC Converter for Mobile and Portable Applications

Bit	Symbol	Description
[3]	E_PG1	PG1 caused event. Write 1 to clear this bit after the event source has been released.
[2]	E_OV1	OV1 caused event. Write 1 to clear this bit after the event source has been released.
[1]	E_UV1	UV1 caused event. Write 1 to clear this bit after the event source has been released.
[0]	E_OC1	OC1 caused event. Write 1 to clear this bit after the event source has been released.

Table 25: SYS_EVENT_2 (0x0006)

Bit	Symbol	Description
[2]	E_GPIO2	GPIO2 event. Write 1 to clear this bit after the event source has been released.
[1]	E_GPIO1	GPIO1 event. Write 1 to clear this bit after the event source has been released.
[0]	E_GPIO0	GPIO0 event. Write 1 to clear this bit after the event source has been released.

Table 26: SYS_MASK_0 (0x0007)

Bit	Symbol	Description
[2]	M_SG	SG IRQ mask
[1]	M_TEMP_CRIT	TEMP_CRIT IRQ mask
[0]	M_TEMP_WARN	TEMP_WARN IRQ mask

Table 27: SYS_MASK_1 (0x0008)

Bit	Symbol	Description
[7]	M_PG2	PG2 event IRQ mask
[6]	M_OV2	OV2 event IRQ mask
[5]	M_UV2	UV2 event IRQ mask
[4]	M_OC2	OC2 event IRQ mask
[3]	M_PG1	PG1 event IRQ mask
[2]	M_OV1	OV1 event IRQ mask
[1]	M_UV1	UV1 event IRQ mask
[0]	M_OC1	OC1 event IRQ mask

Table 28: SYS_MASK_2 (0x0009)

Bit	Symbol	Description
[2]	M_GPIO2	GPIO2 IRQ mask
[1]	M_GPIO1	GPIO1 IRQ mask
[0]	M_GPIO0	GPIO0 IRQ mask

High-Performance, Dual-Channel DC-DC Converter for Mobile and Portable Applications

Table 29: SYS_MASK_3 (0x000A)

Bit	Symbol	Description
[3]	M_VR_HOT	Temp warning status IRQ mask. Initial value is determined by CONF pin setting at the start-up if CONF_EN = 1, see Section 4.2.3.3
[2]	M_SG_STAT	SG status IRQ mask Initial value is determined by CONF pin setting at the start-up if CONF_EN = 1, see Section 4.2.3.3
[1]	M_PG2_STAT	PG2 status IRQ mask. Initial value is determined by CONF pin setting at the start-up if CONF_EN = 1, see Section 4.2.3.3
[0]	M_PG1_STAT	PG1 status IRQ mask. Initial value is determined by CONF pin setting at the start-up if CONF_EN = 1, see Section 4.2.3.3

Table 30: SYS_CONFIG_0 (0x000B)

Bit	Symbol	Description																																		
[7:4]	CH1_DIS_DLY	<p>Delay for CH1 disable. Active with GPIO configured as EN1&EN2 control and IC_EN control. Initial value is determined by CONF pin setting at the start-up in CONF_EN = 1</p> <table border="1"> <thead> <tr> <th>Value</th> <th>Description</th> </tr> </thead> <tbody> <tr><td>0x0</td><td>0</td></tr> <tr><td>0x1</td><td>1.0 ms</td></tr> <tr><td>0x2</td><td>2.0 ms</td></tr> <tr><td>0x3</td><td>3.0 ms</td></tr> <tr><td>0x4</td><td>4.0 ms</td></tr> <tr><td>0x5</td><td>5.0 ms</td></tr> <tr><td>0x6</td><td>6.0 ms</td></tr> <tr><td>0x7</td><td>7.0 ms</td></tr> <tr><td>0x8</td><td>8.0 ms</td></tr> <tr><td>0x9</td><td>9.0 ms</td></tr> <tr><td>0xA</td><td>10.0 ms</td></tr> <tr><td>0xB</td><td>11.0 ms</td></tr> <tr><td>0xC</td><td>12.0 ms</td></tr> <tr><td>0xD</td><td>13.0 ms</td></tr> <tr><td>0xE</td><td>14.0 ms</td></tr> <tr><td>0xF</td><td>15.0 ms</td></tr> </tbody> </table>	Value	Description	0x0	0	0x1	1.0 ms	0x2	2.0 ms	0x3	3.0 ms	0x4	4.0 ms	0x5	5.0 ms	0x6	6.0 ms	0x7	7.0 ms	0x8	8.0 ms	0x9	9.0 ms	0xA	10.0 ms	0xB	11.0 ms	0xC	12.0 ms	0xD	13.0 ms	0xE	14.0 ms	0xF	15.0 ms
Value	Description																																			
0x0	0																																			
0x1	1.0 ms																																			
0x2	2.0 ms																																			
0x3	3.0 ms																																			
0x4	4.0 ms																																			
0x5	5.0 ms																																			
0x6	6.0 ms																																			
0x7	7.0 ms																																			
0x8	8.0 ms																																			
0x9	9.0 ms																																			
0xA	10.0 ms																																			
0xB	11.0 ms																																			
0xC	12.0 ms																																			
0xD	13.0 ms																																			
0xE	14.0 ms																																			
0xF	15.0 ms																																			
[3:0]	CH1_EN_DLY	<p>Delay for CH1 enable. Active with GPIO configured as EN1&EN2 control and IC_EN control. Initial value is determined by CONF pin setting at the start-up in CONF_EN = 1</p> <table border="1"> <thead> <tr> <th>Value</th> <th>Description</th> </tr> </thead> <tbody> <tr><td>0x0</td><td>0</td></tr> <tr><td>0x1</td><td>0.5 ms</td></tr> <tr><td>0x2</td><td>1.0 ms</td></tr> <tr><td>0x3</td><td>1.5 ms</td></tr> <tr><td>0x4</td><td>2.0 ms</td></tr> </tbody> </table>	Value	Description	0x0	0	0x1	0.5 ms	0x2	1.0 ms	0x3	1.5 ms	0x4	2.0 ms																						
Value	Description																																			
0x0	0																																			
0x1	0.5 ms																																			
0x2	1.0 ms																																			
0x3	1.5 ms																																			
0x4	2.0 ms																																			

High-Performance, Dual-Channel DC-DC Converter for Mobile and Portable Applications

Bit	Symbol	Description
		0x5 2.5 ms
		0x6 3.0 ms
		0x7 3.5 ms
		0x8 4.0 ms
		0x9 4.5 ms
		0xA 5.0 ms
		0xB 5.5 ms
		0xC 6.0 ms
		0xD 6.5 ms
		0xE 7.0 ms
		0xF 7.5 ms

Table 31: SYS_CONFIG_1 (0x000C)

Bit	Symbol	Description
		Delay for CH2 disable. Active with GPIO configured as EN1&EN2 control and IC_EN control. Initial value is determined by CONF pin setting at the start-up in CONF_EN = 1
		Value Description
		0x0 0
		0x1 1.0 ms
		0x2 2.0 ms
		0x3 3.0 ms
		0x4 4.0 ms
		0x5 5.0 ms
[7:4]	CH2_DIS_DLY	0x6 6.0 ms
		0x7 7.0 ms
		0x8 8.0 ms
		0x9 9.0 ms
		0xA 10.0 ms
		0xB 11.0 ms
		0xC 12.0 ms
		0xD 13.0 ms
		0xE 14.0 ms
		0xF 15.0 ms
		Delay for CH2 enable. Active with GPIO configured as EN1&EN2 control and IC_EN control. Initial value is determined by CONF pin setting at the start-up in CONF_EN = 1
		Value Description
[3:0]	CH2_EN_DLY	0x0 0

High-Performance, Dual-Channel DC-DC Converter for Mobile and Portable Applications

Bit	Symbol	Description
		0x1 0.5 ms
		0x2 1.0 ms
		0x3 1.5 ms
		0x4 2.0 ms
		0x5 2.5 ms
		0x6 3.0 ms
		0x7 3.5 ms
		0x8 4.0 ms
		0x9 4.5 ms
		0xA 5.0 ms
		0xB 5.5 ms
		0xC 6.0 ms
		0xD 6.5 ms
		0xE 7.0 ms
		0xF 7.5 ms

Table 32: SYS_CONFIG_2 (0x000D)

Bit	Symbol	Description										
[6:5]	OC_LATCHOFF	Over-current latch-off setting. BUCK shut-down after OCP for 8 μ s/1 ms/3 ms unless disable setting. IRQ is generated unless IRQ is masked. <table border="1"> <thead> <tr> <th>Value</th> <th>Description</th> </tr> </thead> <tbody> <tr> <td>0x0</td> <td>Latch off disable</td> </tr> <tr> <td>0x1</td> <td>Latch off after 8 μs of OCP signal</td> </tr> <tr> <td>0x2</td> <td>Latch off after 1 ms of OCP signal</td> </tr> <tr> <td>0x3</td> <td>Latch off after 3 ms of OCP signal</td> </tr> </tbody> </table>	Value	Description	0x0	Latch off disable	0x1	Latch off after 8 μ s of OCP signal	0x2	Latch off after 1 ms of OCP signal	0x3	Latch off after 3 ms of OCP signal
Value	Description											
0x0	Latch off disable											
0x1	Latch off after 8 μ s of OCP signal											
0x2	Latch off after 1 ms of OCP signal											
0x3	Latch off after 3 ms of OCP signal											
[4]	OC_DVC_MASK	Over-current event (IRQ and latch-off feature) mask during DVC ramp-up and ramp-down for both CH1 and CH2										
[3:2]	PG_DVC_MASK	Power-good mask during DVC for both CH1 and CH2 <table border="1"> <thead> <tr> <th>Value</th> <th>Description</th> </tr> </thead> <tbody> <tr> <td>0x0</td> <td>No mask</td> </tr> <tr> <td>0x1</td> <td>Mask as not power-good during DVC</td> </tr> <tr> <td>0x2</td> <td>Mask as power-good during DVC</td> </tr> <tr> <td>0x3</td> <td>Reserved</td> </tr> </tbody> </table>	Value	Description	0x0	No mask	0x1	Mask as not power-good during DVC	0x2	Mask as power-good during DVC	0x3	Reserved
Value	Description											
0x0	No mask											
0x1	Mask as not power-good during DVC											
0x2	Mask as power-good during DVC											
0x3	Reserved											

Table 33: SYS_CONFIG_3 (0x000E)

Bit	Symbol	Description
[6:4]	OSC_TUNE	Tune oscillator frequency, tuned frequency = Current + OSC_TUNE * 160 kHz

High-Performance, Dual-Channel DC-DC Converter for Mobile and Portable Applications

Bit	Symbol	Description																		
		<table border="1"> <thead> <tr> <th>Value</th> <th>Description</th> </tr> </thead> <tbody> <tr> <td>0x3</td> <td>3</td> </tr> <tr> <td>0x2</td> <td>2</td> </tr> <tr> <td>0x1</td> <td>1</td> </tr> <tr> <td>0x0</td> <td>0</td> </tr> <tr> <td>0x7</td> <td>-1</td> </tr> <tr> <td>0x6</td> <td>-2</td> </tr> <tr> <td>0x5</td> <td>-3</td> </tr> <tr> <td>0x4</td> <td>-4</td> </tr> </tbody> </table>	Value	Description	0x3	3	0x2	2	0x1	1	0x0	0	0x7	-1	0x6	-2	0x5	-3	0x4	-4
Value	Description																			
0x3	3																			
0x2	2																			
0x1	1																			
0x0	0																			
0x7	-1																			
0x6	-2																			
0x5	-3																			
0x4	-4																			
[1]	I2C_TIMEOUT	Enable automatic reset of 2-wire interface (if SDA stays low for >50 ms).																		

Table 34: SYS_GPIO0_0 (0x0010)

Bit	Symbol	Description																																		
		GPIO function mode select <table border="1"> <thead> <tr> <th>Value</th> <th>Description</th> </tr> </thead> <tbody> <tr> <td>0x0</td> <td>GPIO disable</td> </tr> <tr> <td>0x1</td> <td>EN1 input</td> </tr> <tr> <td>0x2</td> <td>EN2 input</td> </tr> <tr> <td>0x3</td> <td>EN1 & EN2 input</td> </tr> <tr> <td>0x4</td> <td>DVC1 input</td> </tr> <tr> <td>0x5</td> <td>DVC2 input</td> </tr> <tr> <td>0x6</td> <td>DVC1 & DVC2 input</td> </tr> <tr> <td>0x7</td> <td>RELOAD input</td> </tr> <tr> <td>0x8</td> <td>PG1 output</td> </tr> <tr> <td>0x9</td> <td>PG2 output</td> </tr> <tr> <td>0xA</td> <td>PG1 & PG2 output</td> </tr> <tr> <td>0xB</td> <td>SG output</td> </tr> <tr> <td>0xC</td> <td>nIRQ output</td> </tr> <tr> <td>0xD</td> <td>Reserved</td> </tr> <tr> <td>0xE</td> <td>Low output</td> </tr> <tr> <td>0xF</td> <td>High output</td> </tr> </tbody> </table>	Value	Description	0x0	GPIO disable	0x1	EN1 input	0x2	EN2 input	0x3	EN1 & EN2 input	0x4	DVC1 input	0x5	DVC2 input	0x6	DVC1 & DVC2 input	0x7	RELOAD input	0x8	PG1 output	0x9	PG2 output	0xA	PG1 & PG2 output	0xB	SG output	0xC	nIRQ output	0xD	Reserved	0xE	Low output	0xF	High output
Value	Description																																			
0x0	GPIO disable																																			
0x1	EN1 input																																			
0x2	EN2 input																																			
0x3	EN1 & EN2 input																																			
0x4	DVC1 input																																			
0x5	DVC2 input																																			
0x6	DVC1 & DVC2 input																																			
0x7	RELOAD input																																			
0x8	PG1 output																																			
0x9	PG2 output																																			
0xA	PG1 & PG2 output																																			
0xB	SG output																																			
0xC	nIRQ output																																			
0xD	Reserved																																			
0xE	Low output																																			
0xF	High output																																			
[4:1]	GPIO0_MODE																																			
		GPIO output buffer select <table border="1"> <thead> <tr> <th>Value</th> <th>Description</th> </tr> </thead> <tbody> <tr> <td>0x0</td> <td>open-drain output</td> </tr> <tr> <td>0x1</td> <td>push-pull output</td> </tr> </tbody> </table>	Value	Description	0x0	open-drain output	0x1	push-pull output																												
Value	Description																																			
0x0	open-drain output																																			
0x1	push-pull output																																			
[0]	GPIO0_OBUF																																			

High-Performance, Dual-Channel DC-DC Converter for Mobile and Portable Applications

Table 35: SYS_GPIO0_1 (0x0011)

Bit	Symbol	Description										
[7]	GPIO0_DEB_FALL	GPI debounce falling edge										
[6]	GPIO0_DEB_RISE	GPI debounce rising edge										
[5:4]	GPIO0_DEB	<p>GPI debounce time</p> <table> <thead> <tr> <th>Value</th> <th>Description</th> </tr> </thead> <tbody> <tr> <td>0x0</td> <td>100 μs debounce</td> </tr> <tr> <td>0x1</td> <td>1 ms debounce</td> </tr> <tr> <td>0x2</td> <td>10 ms debounce</td> </tr> <tr> <td>0x3</td> <td>100 ms debounce</td> </tr> </tbody> </table>	Value	Description	0x0	100 μ s debounce	0x1	1 ms debounce	0x2	10 ms debounce	0x3	100 ms debounce
Value	Description											
0x0	100 μ s debounce											
0x1	1 ms debounce											
0x2	10 ms debounce											
0x3	100 ms debounce											
[3]	GPIO0_PUPD	<p>GPIO pull-up/pull-down enable</p> <table> <thead> <tr> <th>Value</th> <th>Description</th> </tr> </thead> <tbody> <tr> <td>0x0</td> <td>GPI: pull-down disabled, GPO: pull-up to AVDD disabled</td> </tr> <tr> <td>0x1</td> <td>GPI: pull-down enabled, GPO: pull-up to AVDD enabled</td> </tr> </tbody> </table>	Value	Description	0x0	GPI: pull-down disabled, GPO: pull-up to AVDD disabled	0x1	GPI: pull-down enabled, GPO: pull-up to AVDD enabled				
Value	Description											
0x0	GPI: pull-down disabled, GPO: pull-up to AVDD disabled											
0x1	GPI: pull-down enabled, GPO: pull-up to AVDD enabled											
[2]	GPIO0_POL	<p>GPIO polarity</p> <table> <thead> <tr> <th>Value</th> <th>Description</th> </tr> </thead> <tbody> <tr> <td>0x0</td> <td>GPIO is active-high</td> </tr> <tr> <td>0x1</td> <td>GPIO is active-low</td> </tr> </tbody> </table>	Value	Description	0x0	GPIO is active-high	0x1	GPIO is active-low				
Value	Description											
0x0	GPIO is active-high											
0x1	GPIO is active-low											
[1:0]	GPIO0_TRIG	<p>GPI trigger type</p> <table> <thead> <tr> <th>Value</th> <th>Description</th> </tr> </thead> <tbody> <tr> <td>0x0</td> <td>Dual-edge triggered</td> </tr> <tr> <td>0x1</td> <td>Pos-edge triggered</td> </tr> <tr> <td>0x2</td> <td>Neg-edge triggered</td> </tr> <tr> <td>0x3</td> <td>Reserved (No trigger)</td> </tr> </tbody> </table>	Value	Description	0x0	Dual-edge triggered	0x1	Pos-edge triggered	0x2	Neg-edge triggered	0x3	Reserved (No trigger)
Value	Description											
0x0	Dual-edge triggered											
0x1	Pos-edge triggered											
0x2	Neg-edge triggered											
0x3	Reserved (No trigger)											

Table 36: SYS_GPIO1_0 (0x0012)

Bit	Symbol	Description																		
[4:1]	GPIO1_MODE	<p>GPIO function mode select. Initial value is determined by CONF pin setting at the start-up in CONF_EN = 1</p> <table> <thead> <tr> <th>Value</th> <th>Description</th> </tr> </thead> <tbody> <tr> <td>0x0</td> <td>GPIO disable</td> </tr> <tr> <td>0x1</td> <td>EN1 input</td> </tr> <tr> <td>0x2</td> <td>EN2 input</td> </tr> <tr> <td>0x3</td> <td>EN1 & EN2 input</td> </tr> <tr> <td>0x4</td> <td>DVC1 input</td> </tr> <tr> <td>0x5</td> <td>DVC2 input</td> </tr> <tr> <td>0x6</td> <td>DVC1 & DVC2 input</td> </tr> <tr> <td>0x7</td> <td>RELOAD input</td> </tr> </tbody> </table>	Value	Description	0x0	GPIO disable	0x1	EN1 input	0x2	EN2 input	0x3	EN1 & EN2 input	0x4	DVC1 input	0x5	DVC2 input	0x6	DVC1 & DVC2 input	0x7	RELOAD input
Value	Description																			
0x0	GPIO disable																			
0x1	EN1 input																			
0x2	EN2 input																			
0x3	EN1 & EN2 input																			
0x4	DVC1 input																			
0x5	DVC2 input																			
0x6	DVC1 & DVC2 input																			
0x7	RELOAD input																			

High-Performance, Dual-Channel DC-DC Converter for Mobile and Portable Applications

Bit	Symbol	Description						
		0x8 PG1 output 0x9 PG2 output 0xA PG1 & PG2 output 0xB SG output 0xC nIRQ output 0xD Reserved 0xE Low output 0xF High output						
[0]	GPIO1_OBUF	GPIO output buffer select. Initial value is determined by CONF pin setting at the start-up in CONF_EN = 1 <table border="1"> <thead> <tr> <th>Value</th> <th>Description</th> </tr> </thead> <tbody> <tr> <td>0x0</td> <td>open-drain output</td> </tr> <tr> <td>0x1</td> <td>push-pull output</td> </tr> </tbody> </table>	Value	Description	0x0	open-drain output	0x1	push-pull output
Value	Description							
0x0	open-drain output							
0x1	push-pull output							

Table 37: SYS_GPIO1_1 (0x0013)

Bit	Symbol	Description										
[7]	GPIO1_DEB_FALL	GPIO debounce falling edge. Initial value is determined by CONF pin setting at the start-up in CONF_EN = 1										
[6]	GPIO1_DEB_RISE	GPIO debounce rising edge. Initial value is determined by CONF pin setting at the start-up in CONF_EN = 1										
[5:4]	GPIO1_DEB	GPIO debounce time. Initial value is determined by CONF pin setting at the start-up in CONF_EN = 1 <table border="1"> <thead> <tr> <th>Value</th> <th>Description</th> </tr> </thead> <tbody> <tr> <td>0x0</td> <td>100 µs debounce</td> </tr> <tr> <td>0x1</td> <td>1 ms debounce</td> </tr> <tr> <td>0x2</td> <td>10 ms debounce</td> </tr> <tr> <td>0x3</td> <td>100 ms debounce</td> </tr> </tbody> </table>	Value	Description	0x0	100 µs debounce	0x1	1 ms debounce	0x2	10 ms debounce	0x3	100 ms debounce
Value	Description											
0x0	100 µs debounce											
0x1	1 ms debounce											
0x2	10 ms debounce											
0x3	100 ms debounce											
[3]	GPIO1_PUPD	GPIO pull-up/pull-down enable. Initial value is determined by CONF pin setting at the start-up in CONF_EN = 1 <table border="1"> <thead> <tr> <th>Value</th> <th>Description</th> </tr> </thead> <tbody> <tr> <td>0x0</td> <td>GPI: pull-down disabled, GPO: pull-up to AVDD disabled</td> </tr> <tr> <td>0x1</td> <td>GPI: pull-down enabled, GPO: pull-up to AVDD enabled</td> </tr> </tbody> </table>	Value	Description	0x0	GPI: pull-down disabled, GPO: pull-up to AVDD disabled	0x1	GPI: pull-down enabled, GPO: pull-up to AVDD enabled				
Value	Description											
0x0	GPI: pull-down disabled, GPO: pull-up to AVDD disabled											
0x1	GPI: pull-down enabled, GPO: pull-up to AVDD enabled											
[2]	GPIO1_POL	GPIO polarity. Initial value is determined by CONF pin setting at the start-up in CONF_EN = 1 <table border="1"> <thead> <tr> <th>Value</th> <th>Description</th> </tr> </thead> <tbody> <tr> <td>0x0</td> <td>GPIO is active-high</td> </tr> <tr> <td>0x1</td> <td>GPIO is active-low</td> </tr> </tbody> </table>	Value	Description	0x0	GPIO is active-high	0x1	GPIO is active-low				
Value	Description											
0x0	GPIO is active-high											
0x1	GPIO is active-low											
[1:0]	GPIO1_TRIG	GPI trigger type. Initial value is determined by CONF pin setting at the start-up in CONF_EN = 1 <table border="1"> <thead> <tr> <th>Value</th> <th>Description</th> </tr> </thead> </table>	Value	Description								
Value	Description											

High-Performance, Dual-Channel DC-DC Converter for Mobile and Portable Applications

		0x0	Dual-edge triggered
		0x1	Pos-edge triggered
		0x2	Neg-edge triggered
		0x3	Reserved (No trigger)

Table 38: SYS_GPIO2_0 (0x0014)

Bit	Symbol	Description																																		
[4:1]	GPIO2_MODE	<p>GPIO function mode select. Initial value is determined by CONF pin setting at the start-up in CONF_EN = 1</p> <table border="1"> <thead> <tr> <th>Value</th> <th>Description</th> </tr> </thead> <tbody> <tr> <td>0x0</td> <td>GPIO disable</td> </tr> <tr> <td>0x1</td> <td>EN1 input</td> </tr> <tr> <td>0x2</td> <td>EN2 input</td> </tr> <tr> <td>0x3</td> <td>EN1 & EN2 input</td> </tr> <tr> <td>0x4</td> <td>DVC1 input</td> </tr> <tr> <td>0x5</td> <td>DVC2 input</td> </tr> <tr> <td>0x6</td> <td>DVC1 & DVC2 input</td> </tr> <tr> <td>0x7</td> <td>RELOAD input</td> </tr> <tr> <td>0x8</td> <td>PG1 output</td> </tr> <tr> <td>0x9</td> <td>PG2 output</td> </tr> <tr> <td>0xA</td> <td>PG1 & PG2 output</td> </tr> <tr> <td>0xB</td> <td>SG output</td> </tr> <tr> <td>0xC</td> <td>nIRQ output</td> </tr> <tr> <td>0xD</td> <td>Reserved</td> </tr> <tr> <td>0xE</td> <td>Low output</td> </tr> <tr> <td>0xF</td> <td>High output</td> </tr> </tbody> </table>	Value	Description	0x0	GPIO disable	0x1	EN1 input	0x2	EN2 input	0x3	EN1 & EN2 input	0x4	DVC1 input	0x5	DVC2 input	0x6	DVC1 & DVC2 input	0x7	RELOAD input	0x8	PG1 output	0x9	PG2 output	0xA	PG1 & PG2 output	0xB	SG output	0xC	nIRQ output	0xD	Reserved	0xE	Low output	0xF	High output
Value	Description																																			
0x0	GPIO disable																																			
0x1	EN1 input																																			
0x2	EN2 input																																			
0x3	EN1 & EN2 input																																			
0x4	DVC1 input																																			
0x5	DVC2 input																																			
0x6	DVC1 & DVC2 input																																			
0x7	RELOAD input																																			
0x8	PG1 output																																			
0x9	PG2 output																																			
0xA	PG1 & PG2 output																																			
0xB	SG output																																			
0xC	nIRQ output																																			
0xD	Reserved																																			
0xE	Low output																																			
0xF	High output																																			
[0]	GPIO2_OBUF	<p>GPIO output buffer select. Initial value is determined by CONF pin setting at the start-up in CONF_EN = 1</p> <table border="1"> <thead> <tr> <th>Value</th> <th>Description</th> </tr> </thead> <tbody> <tr> <td>0x0</td> <td>open-drain output</td> </tr> <tr> <td>0x1</td> <td>push-pull output</td> </tr> </tbody> </table>	Value	Description	0x0	open-drain output	0x1	push-pull output																												
Value	Description																																			
0x0	open-drain output																																			
0x1	push-pull output																																			

Table 39: SYS_GPIO2_1 (0x0015)

Bit	Symbol	Description
[7]	GPIO2_DEB_FALL	GPI debounce falling edge. Initial value is determined by CONF pin setting at the start-up in CONF_EN = 1
[6]	GPIO2_DEB_RISE	GPI debounce rising edge. Initial value is determined by CONF pin setting at the start-up in CONF_EN = 1
[5:4]	GPIO2_DEB	GPI debounce time. Initial value is determined by CONF pin setting at the start-up in CONF_EN = 1

High-Performance, Dual-Channel DC-DC Converter for Mobile and Portable Applications

Bit	Symbol	Description										
		<table border="1"> <thead> <tr> <th>Value</th> <th>Description</th> </tr> </thead> <tbody> <tr> <td>0x0</td> <td>100 µs debounce</td> </tr> <tr> <td>0x1</td> <td>1 ms debounce</td> </tr> <tr> <td>0x2</td> <td>10 ms debounce</td> </tr> <tr> <td>0x3</td> <td>100 ms debounce</td> </tr> </tbody> </table>	Value	Description	0x0	100 µs debounce	0x1	1 ms debounce	0x2	10 ms debounce	0x3	100 ms debounce
Value	Description											
0x0	100 µs debounce											
0x1	1 ms debounce											
0x2	10 ms debounce											
0x3	100 ms debounce											
[3]	GPIO2_PUPD	<p>GPIO pull-up/pull-down enable. Initial value is determined by CONF pin setting at the start-up in CONF_EN = 1</p> <table border="1"> <thead> <tr> <th>Value</th> <th>Description</th> </tr> </thead> <tbody> <tr> <td>0x0</td> <td>GPI: pull-down disabled, GPO: pull-up to AVDD disabled</td> </tr> <tr> <td>0x1</td> <td>GPI: pull-down enabled, GPO: pull-up to AVDD enabled</td> </tr> </tbody> </table>	Value	Description	0x0	GPI: pull-down disabled, GPO: pull-up to AVDD disabled	0x1	GPI: pull-down enabled, GPO: pull-up to AVDD enabled				
Value	Description											
0x0	GPI: pull-down disabled, GPO: pull-up to AVDD disabled											
0x1	GPI: pull-down enabled, GPO: pull-up to AVDD enabled											
[2]	GPIO2_POL	<p>GPIO polarity. Initial value is determined by CONF pin setting at the start-up in CONF_EN = 1</p> <table border="1"> <thead> <tr> <th>Value</th> <th>Description</th> </tr> </thead> <tbody> <tr> <td>0x0</td> <td>GPIO is active-high</td> </tr> <tr> <td>0x1</td> <td>GPIO is active-low</td> </tr> </tbody> </table>	Value	Description	0x0	GPIO is active-high	0x1	GPIO is active-low				
Value	Description											
0x0	GPIO is active-high											
0x1	GPIO is active-low											
[1:0]	GPIO2_TRIG	<p>GPI trigger type. Initial value is determined by CONF pin setting at the start-up in CONF_EN = 1</p> <table border="1"> <thead> <tr> <th>Value</th> <th>Description</th> </tr> </thead> <tbody> <tr> <td>0x0</td> <td>Dual-edge triggered</td> </tr> <tr> <td>0x1</td> <td>Pos-edge triggered</td> </tr> <tr> <td>0x2</td> <td>Neg-edge triggered</td> </tr> <tr> <td>0x3</td> <td>Reserved (No trigger)</td> </tr> </tbody> </table>	Value	Description	0x0	Dual-edge triggered	0x1	Pos-edge triggered	0x2	Neg-edge triggered	0x3	Reserved (No trigger)
Value	Description											
0x0	Dual-edge triggered											
0x1	Pos-edge triggered											
0x2	Neg-edge triggered											
0x3	Reserved (No trigger)											

High-Performance, Dual-Channel DC-DC Converter for Mobile and Portable Applications

5.1.2 Buck1

Table 40: BUCK_BUCK1_0 (0x0020)

Bit	Symbol	Description																		
[6:4]	CH1_SR_DVC_DWN	Voltage slew-rate for DVC ramp-down <table border="1"> <thead> <tr> <th>Value</th> <th>Description</th> </tr> </thead> <tbody> <tr> <td>0x0</td> <td>10 mV/8 μs</td> </tr> <tr> <td>0x1</td> <td>10 mV/4 μs</td> </tr> <tr> <td>0x2</td> <td>10 mV/2 μs</td> </tr> <tr> <td>0x3</td> <td>10 mV/μs</td> </tr> <tr> <td>0x4</td> <td>20 mV/μs</td> </tr> <tr> <td>0x5</td> <td>Reserved</td> </tr> <tr> <td>0x6</td> <td>Reserved</td> </tr> <tr> <td>0x7</td> <td>Reserved</td> </tr> </tbody> </table>	Value	Description	0x0	10 mV/8 μ s	0x1	10 mV/4 μ s	0x2	10 mV/2 μ s	0x3	10 mV/ μ s	0x4	20 mV/μs	0x5	Reserved	0x6	Reserved	0x7	Reserved
Value	Description																			
0x0	10 mV/8 μ s																			
0x1	10 mV/4 μ s																			
0x2	10 mV/2 μ s																			
0x3	10 mV/ μ s																			
0x4	20 mV/μs																			
0x5	Reserved																			
0x6	Reserved																			
0x7	Reserved																			
[3:1]	CH1_SR_DVC_UP	Voltage slew-rate for DVC ramp-up <table border="1"> <thead> <tr> <th>Value</th> <th>Description</th> </tr> </thead> <tbody> <tr> <td>0x0</td> <td>10 mV/8 μs</td> </tr> <tr> <td>0x1</td> <td>10 mV/4 μs</td> </tr> <tr> <td>0x2</td> <td>10 mV/2 μs</td> </tr> <tr> <td>0x3</td> <td>10 mV/μs</td> </tr> <tr> <td>0x4</td> <td>20 mV/μs</td> </tr> <tr> <td>0x5</td> <td>40 mV/μs</td> </tr> <tr> <td>0x6</td> <td>Reserved</td> </tr> <tr> <td>0x7</td> <td>Reserved</td> </tr> </tbody> </table>	Value	Description	0x0	10 mV/8 μ s	0x1	10 mV/4 μ s	0x2	10 mV/2 μ s	0x3	10 mV/ μ s	0x4	20 mV/μs	0x5	40 mV/ μ s	0x6	Reserved	0x7	Reserved
Value	Description																			
0x0	10 mV/8 μ s																			
0x1	10 mV/4 μ s																			
0x2	10 mV/2 μ s																			
0x3	10 mV/ μ s																			
0x4	20 mV/μs																			
0x5	40 mV/ μ s																			
0x6	Reserved																			
0x7	Reserved																			
[0]	CH1_EN	Channel enable. Initial value is determined by CONF pin setting at the start-up in CONF_EN = 1																		

Table 41: BUCK_BUCK1_1 (0x0021)

Bit	Symbol	Description																		
[6:4]	CH1_SR_SHDN	Voltage slew-rate during shut-down <table border="1"> <thead> <tr> <th>Value</th> <th>Description</th> </tr> </thead> <tbody> <tr> <td>0x0</td> <td>10 mV/8 μs</td> </tr> <tr> <td>0x1</td> <td>10 mV/4 μs</td> </tr> <tr> <td>0x2</td> <td>10 mV/2 μs</td> </tr> <tr> <td>0x3</td> <td>10 mV/μs</td> </tr> <tr> <td>0x4</td> <td>20 mV/μs</td> </tr> <tr> <td>0x5</td> <td>Reserved</td> </tr> <tr> <td>0x6</td> <td>Reserved</td> </tr> <tr> <td>0x7</td> <td>Immediate power-down</td> </tr> </tbody> </table>	Value	Description	0x0	10 mV/8 μ s	0x1	10 mV/4 μ s	0x2	10 mV/2 μ s	0x3	10 mV/ μ s	0x4	20 mV/μs	0x5	Reserved	0x6	Reserved	0x7	Immediate power-down
Value	Description																			
0x0	10 mV/8 μ s																			
0x1	10 mV/4 μ s																			
0x2	10 mV/2 μ s																			
0x3	10 mV/ μ s																			
0x4	20 mV/μs																			
0x5	Reserved																			
0x6	Reserved																			
0x7	Immediate power-down																			

High-Performance, Dual-Channel DC-DC Converter for Mobile and Portable Applications

Bit	Symbol	Description
[3:1]	CH1_SR_STARTUP	Voltage slew-rate during startup
		Value Description
		0x0 10 mV/8 μ s
		0x1 10 mV/4 μ s
		0x2 10 mV/2 μ s
		0x3 10 mV/ μ s
		0x4 20 mV/μs
		0x5 40 mV/ μ s
		0x6 Reserved
0x7 Reserved		
[0]	CH1_PD_DIS	Pull-down while buck is disabled. 0: enable, 1: disable

Table 42: BUCK_BUCK1_2 (0x0022)

Bit	Symbol	Description
[3:0]	CH1_ILIM	Select OCP threshold (A)
		Value Description
		0x0 Reserved
		0x1 3.5
		0x2 4.0
		0x3 4.5
		0x4 5.0
		0x5 5.5
		0x6 6.0
		0x7 6.5
		0x8 7.0
		0x9 7.5
		0xA 8.0
		0xB 8.5
		0xC 9.0
		0xD 9.5
		0xE 10.0
0xF Disable		

Table 43: BUCK_BUCK1_3 (0x0023)

Bit	Symbol	Description
[7:0]	CH1_VMAX	VOUT max setting (V): From 0.30 V (0x1E) to 1.90 V (0xBE) in 10 mV steps. This is a read-only register.
		Value Description

High-Performance, Dual-Channel DC-DC Converter for Mobile and Portable Applications

Bit	Symbol	Description
		0x1E 0.3
		0x1F 0.31
		0x20 0.32
		Continuing through...
		0x99 1.53
		To...
		0xBD 1.89
		0xBE 1.9

Table 44: BUCK_BUCK1_4 (0x0024)

Bit	Symbol	Description										
[4]	CH1_VSEL	Output voltage and operation selection: 0: A, 1: B. Initial value is determined by CONF pin setting at the start-up in CONF_EN = 1										
[3:2]	CH1_B_MODE	Operation mode selection. Initial value is determined by CONF pin setting at the start-up in CONF_EN = 1 <table border="1"> <thead> <tr> <th>Value</th> <th>Description</th> </tr> </thead> <tbody> <tr> <td>0x0</td> <td>Force PFM operation</td> </tr> <tr> <td>0x1</td> <td>Force PWM operation</td> </tr> <tr> <td>0x2</td> <td>Force PWM operation</td> </tr> <tr> <td>0x3</td> <td>Auto mode</td> </tr> </tbody> </table>	Value	Description	0x0	Force PFM operation	0x1	Force PWM operation	0x2	Force PWM operation	0x3	Auto mode
Value	Description											
0x0	Force PFM operation											
0x1	Force PWM operation											
0x2	Force PWM operation											
0x3	Auto mode											
[1:0]	CH1_A_MODE	Operation mode selection. Initial value is determined by CONF pin setting at the start-up in CONF_EN = 1 <table border="1"> <thead> <tr> <th>Value</th> <th>Description</th> </tr> </thead> <tbody> <tr> <td>0x0</td> <td>Force PFM operation</td> </tr> <tr> <td>0x1</td> <td>Force PWM operation</td> </tr> <tr> <td>0x2</td> <td>Force PWM operation</td> </tr> <tr> <td>0x3</td> <td>Auto mode</td> </tr> </tbody> </table>	Value	Description	0x0	Force PFM operation	0x1	Force PWM operation	0x2	Force PWM operation	0x3	Auto mode
Value	Description											
0x0	Force PFM operation											
0x1	Force PWM operation											
0x2	Force PWM operation											
0x3	Auto mode											

Table 45: BUCK_BUCK1_5 (0x0025)

Bit	Symbol	Description								
[7:0]	CH1_A_VOUT	Output voltage setting A: Initial value is determined by CONF pin setting at the start-up in CONF_EN = 1 From 0.30 V (0x1E) to 1.90 V (0xBE) in steps of 10 mV (default 1.0 V) Write-protected when value is written below 0.30 V or above 1.90 V <table border="1"> <thead> <tr> <th>Value</th> <th>Description</th> </tr> </thead> <tbody> <tr> <td>0x1E</td> <td>0.3</td> </tr> <tr> <td>0x1F</td> <td>0.31</td> </tr> <tr> <td>0x20</td> <td>0.32</td> </tr> </tbody> </table>	Value	Description	0x1E	0.3	0x1F	0.31	0x20	0.32
Value	Description									
0x1E	0.3									
0x1F	0.31									
0x20	0.32									

High-Performance, Dual-Channel DC-DC Converter for Mobile and Portable Applications

Bit	Symbol	Description
		Continuing through...
		0x64 1
		To...
		0xBC 1.88
		0xBD 1.89
		0xBE 1.9

Table 46: BUCK_BUCK1_6 (0x0026)

Bit	Symbol	Description
[7:0]	CH1_B_VOUT	Output voltage setting B: Initial value is determined by CONF pin setting at the start-up in CONF_EN = 1 From 0.30 V (0x1E) to 1.90 V (0xBE) in steps of 10 mV (default 1.0 V) Write-protected when value is written below 0.30 V or above 1.90 V
		Value Description
		0x1E 0.3
		0x1F 0.31
		0x20 0.32
		Continuing through...
		0x64 1
		To...
		0xBC 1.88
		0xBD 1.89
		0xBE 1.9

Table 47: BUCK_BUCK1_7 (0x0027)

Bit	Symbol	Description
[3]	Reserved	Reserved
[2]	Reserved	Reserved
[1:0]	CH1_RIPPLE_CANCEL	Ripple cancel control (can be used to improve output overshoot at heavy to light load transient).
		Value Description
		0x0 No ripple cancel
		0x1 Small ripple cancel
		0x2 Mid ripple cancel
		0x3 Large ripple cancel

High-Performance, Dual-Channel DC-DC Converter for Mobile and Portable Applications

5.1.3 Buck2

Table 48: BUCK_BUCK2_0 (0x0028)

Bit	Symbol	Description																		
[6:4]	CH2_SR_DVC_DWN	Voltage slew-rate for DVC ramp-down <table border="1"> <thead> <tr> <th>Value</th> <th>Description</th> </tr> </thead> <tbody> <tr> <td>0x0</td> <td>10 mV/8 μs</td> </tr> <tr> <td>0x1</td> <td>10 mV/4 μs</td> </tr> <tr> <td>0x2</td> <td>10 mV/2 μs</td> </tr> <tr> <td>0x3</td> <td>10 mV/μs</td> </tr> <tr> <td>0x4</td> <td>20 mV/μs</td> </tr> <tr> <td>0x5</td> <td>Reserved</td> </tr> <tr> <td>0x6</td> <td>Reserved</td> </tr> <tr> <td>0x7</td> <td>Reserved</td> </tr> </tbody> </table>	Value	Description	0x0	10 mV/8 μ s	0x1	10 mV/4 μ s	0x2	10 mV/2 μ s	0x3	10 mV/ μ s	0x4	20 mV/μs	0x5	Reserved	0x6	Reserved	0x7	Reserved
Value	Description																			
0x0	10 mV/8 μ s																			
0x1	10 mV/4 μ s																			
0x2	10 mV/2 μ s																			
0x3	10 mV/ μ s																			
0x4	20 mV/μs																			
0x5	Reserved																			
0x6	Reserved																			
0x7	Reserved																			
[3:1]	CH2_SR_DVC_UP	Voltage slew-rate for DVC ramp-up <table border="1"> <thead> <tr> <th>Value</th> <th>Description</th> </tr> </thead> <tbody> <tr> <td>0x0</td> <td>10 mV/8 μs</td> </tr> <tr> <td>0x1</td> <td>10 mV/4 μs</td> </tr> <tr> <td>0x2</td> <td>10 mV/2 μs</td> </tr> <tr> <td>0x3</td> <td>10 mV/μs</td> </tr> <tr> <td>0x4</td> <td>20 mV/μs</td> </tr> <tr> <td>0x5</td> <td>40 mV/μs</td> </tr> <tr> <td>0x6</td> <td>Reserved</td> </tr> <tr> <td>0x7</td> <td>Reserved</td> </tr> </tbody> </table>	Value	Description	0x0	10 mV/8 μ s	0x1	10 mV/4 μ s	0x2	10 mV/2 μ s	0x3	10 mV/ μ s	0x4	20 mV/μs	0x5	40 mV/ μ s	0x6	Reserved	0x7	Reserved
Value	Description																			
0x0	10 mV/8 μ s																			
0x1	10 mV/4 μ s																			
0x2	10 mV/2 μ s																			
0x3	10 mV/ μ s																			
0x4	20 mV/μs																			
0x5	40 mV/ μ s																			
0x6	Reserved																			
0x7	Reserved																			
[0]	CH2_EN	Channel enable. Initial value is determined by CONF pin setting at the start-up in CONF_EN = 1																		

Table 49: BUCK_BUCK2_1 (0x0029)

Bit	Symbol	Description																		
[6:4]	CH2_SR_SHDN	Voltage slew-rate during power-down <table border="1"> <thead> <tr> <th>Value</th> <th>Description</th> </tr> </thead> <tbody> <tr> <td>0x0</td> <td>10 mV/8 μs</td> </tr> <tr> <td>0x1</td> <td>10 mV/4 μs</td> </tr> <tr> <td>0x2</td> <td>10 mV/2 μs</td> </tr> <tr> <td>0x3</td> <td>10 mV/μs</td> </tr> <tr> <td>0x4</td> <td>20 mV/μs</td> </tr> <tr> <td>0x5</td> <td>Reserved</td> </tr> <tr> <td>0x6</td> <td>Reserved</td> </tr> <tr> <td>0x7</td> <td>Immediate power-down</td> </tr> </tbody> </table>	Value	Description	0x0	10 mV/8 μ s	0x1	10 mV/4 μ s	0x2	10 mV/2 μ s	0x3	10 mV/ μ s	0x4	20 mV/μs	0x5	Reserved	0x6	Reserved	0x7	Immediate power-down
Value	Description																			
0x0	10 mV/8 μ s																			
0x1	10 mV/4 μ s																			
0x2	10 mV/2 μ s																			
0x3	10 mV/ μ s																			
0x4	20 mV/μs																			
0x5	Reserved																			
0x6	Reserved																			
0x7	Immediate power-down																			

High-Performance, Dual-Channel DC-DC Converter for Mobile and Portable Applications

Bit	Symbol	Description																		
[3:1]	CH2_SR_STARTUP	Voltage slew-rate during startup <table border="1"> <thead> <tr> <th>Value</th> <th>Description</th> </tr> </thead> <tbody> <tr> <td>0x0</td> <td>10 mV/8 μs</td> </tr> <tr> <td>0x1</td> <td>10 mV/4 μs</td> </tr> <tr> <td>0x2</td> <td>10 mV/2 μs</td> </tr> <tr> <td>0x3</td> <td>10 mV/μs</td> </tr> <tr> <td>0x4</td> <td>20 mV/μs</td> </tr> <tr> <td>0x5</td> <td>40 mV/μs</td> </tr> <tr> <td>0x6</td> <td>Reserved</td> </tr> <tr> <td>0x7</td> <td>Reserved</td> </tr> </tbody> </table>	Value	Description	0x0	10 mV/8 μ s	0x1	10 mV/4 μ s	0x2	10 mV/2 μ s	0x3	10 mV/ μ s	0x4	20 mV/μs	0x5	40 mV/ μ s	0x6	Reserved	0x7	Reserved
Value	Description																			
0x0	10 mV/8 μ s																			
0x1	10 mV/4 μ s																			
0x2	10 mV/2 μ s																			
0x3	10 mV/ μ s																			
0x4	20 mV/μs																			
0x5	40 mV/ μ s																			
0x6	Reserved																			
0x7	Reserved																			
[0]	CH2_PD_DIS	Pull-down while BUCK is disabled. 0: enable, 1: disable																		

Table 50: BUCK_BUCK2_2 (0x002A)

Bit	Symbol	Description																																		
[3:0]	CH2_ILIM	Select OCP threshold <table border="1"> <thead> <tr> <th>Value</th> <th>Description</th> </tr> </thead> <tbody> <tr> <td>0x0</td> <td>Reserved</td> </tr> <tr> <td>0x1</td> <td>3.5</td> </tr> <tr> <td>0x2</td> <td>4.0</td> </tr> <tr> <td>0x3</td> <td>4.5</td> </tr> <tr> <td>0x4</td> <td>5.0</td> </tr> <tr> <td>0x5</td> <td>5.5</td> </tr> <tr> <td>0x6</td> <td>6.0</td> </tr> <tr> <td>0x7</td> <td>6.5</td> </tr> <tr> <td>0x8</td> <td>7.0</td> </tr> <tr> <td>0x9</td> <td>7.5</td> </tr> <tr> <td>0xA</td> <td>8.0</td> </tr> <tr> <td>0xB</td> <td>8.5</td> </tr> <tr> <td>0xC</td> <td>9.0</td> </tr> <tr> <td>0xD</td> <td>9.5</td> </tr> <tr> <td>0xE</td> <td>10.0</td> </tr> <tr> <td>0xF</td> <td>Disable</td> </tr> </tbody> </table>	Value	Description	0x0	Reserved	0x1	3.5	0x2	4.0	0x3	4.5	0x4	5.0	0x5	5.5	0x6	6.0	0x7	6.5	0x8	7.0	0x9	7.5	0xA	8.0	0xB	8.5	0xC	9.0	0xD	9.5	0xE	10.0	0xF	Disable
Value	Description																																			
0x0	Reserved																																			
0x1	3.5																																			
0x2	4.0																																			
0x3	4.5																																			
0x4	5.0																																			
0x5	5.5																																			
0x6	6.0																																			
0x7	6.5																																			
0x8	7.0																																			
0x9	7.5																																			
0xA	8.0																																			
0xB	8.5																																			
0xC	9.0																																			
0xD	9.5																																			
0xE	10.0																																			
0xF	Disable																																			

Table 51: BUCK_BUCK2_3 (0x002B)

Bit	Symbol	Description		
[7:0]	CH2_VMAX	VOUT max setting (V): From 0.30 V (0x1E) to 1.90 V (0xBE) in steps of 10 mV This is a read-only register. <table border="1"> <thead> <tr> <th>Value</th> <th>Description</th> </tr> </thead> </table>	Value	Description
Value	Description			

High-Performance, Dual-Channel DC-DC Converter for Mobile and Portable Applications

Bit	Symbol	Description
		0x1E 0.3 0x1F 0.31 0x20 0.32 Continuing through... 0x64 1 To... 0xBC 1.88 0xBD 1.89 0xBE 1.9

Table 52: BUCK_BUCK2_4 (0x002C)

Bit	Symbol	Description										
[4]	CH2_VSEL	Output voltage and operation selection: 0: A, 1: B. Initial value is determined by CONF pin setting at the start-up in CONF_EN = 1										
[3:2]	CH2_B_MODE	Operation mode selection. Initial value is determined by CONF pin setting at the start-up in CONF_EN = 1 <table border="1"> <thead> <tr> <th>Value</th> <th>Description</th> </tr> </thead> <tbody> <tr> <td>0x0</td> <td>Force PFM operation</td> </tr> <tr> <td>0x1</td> <td>Force PWM operation</td> </tr> <tr> <td>0x2</td> <td>Force PWM operation</td> </tr> <tr> <td>0x3</td> <td>Auto mode</td> </tr> </tbody> </table>	Value	Description	0x0	Force PFM operation	0x1	Force PWM operation	0x2	Force PWM operation	0x3	Auto mode
Value	Description											
0x0	Force PFM operation											
0x1	Force PWM operation											
0x2	Force PWM operation											
0x3	Auto mode											
[1:0]	CH2_A_MODE	Operation mode selection. Initial value is determined by CONF pin setting at the start-up in CONF_EN = 1 <table border="1"> <thead> <tr> <th>Value</th> <th>Description</th> </tr> </thead> <tbody> <tr> <td>0x0</td> <td>Force PFM operation</td> </tr> <tr> <td>0x1</td> <td>Force PWM operation</td> </tr> <tr> <td>0x2</td> <td>Force PWM operation</td> </tr> <tr> <td>0x3</td> <td>Auto mode</td> </tr> </tbody> </table>	Value	Description	0x0	Force PFM operation	0x1	Force PWM operation	0x2	Force PWM operation	0x3	Auto mode
Value	Description											
0x0	Force PFM operation											
0x1	Force PWM operation											
0x2	Force PWM operation											
0x3	Auto mode											

Table 53: BUCK_BUCK2_5 (0x002D)

Bit	Symbol	Description										
[7:0]	CH2_A_VOUT	Output voltage setting A: Initial value is determined by CONF pin setting at the start-up in CONF_EN = 1 From 0.30 V (0x1E) to 1.90 V (0xBE) in steps of 10 mV (default 1.0 V) Write-protected when value is written below 0.30 V or above 1.90 V <table border="1"> <thead> <tr> <th>Value</th> <th>Description</th> </tr> </thead> <tbody> <tr> <td>0x1E</td> <td>0.3</td> </tr> <tr> <td>0x1F</td> <td>0.31</td> </tr> <tr> <td>0x20</td> <td>0.32</td> </tr> <tr> <td colspan="2">Continuing through...</td> </tr> </tbody> </table>	Value	Description	0x1E	0.3	0x1F	0.31	0x20	0.32	Continuing through...	
Value	Description											
0x1E	0.3											
0x1F	0.31											
0x20	0.32											
Continuing through...												

High-Performance, Dual-Channel DC-DC Converter for Mobile and Portable Applications

		0x64	1
		To...	
		0xBC	1.88
		0xBD	1.89
		0xBE	1.9

Table 54: BUCK_BUCK2_6 (0x002E)

Bit	Symbol	Description																				
[7:0]	CH2_B_VOUT	<p>Output voltage setting B: Initial value is determined by CONF pin setting at the start-up in CONF_EN = 1 From 0.30 V (0x1E) to 1.90 V (0xBE) in steps of 10 mV (default 1.0 V) Write-protected when value is written below 0.30 V or above 1.90 V</p> <table border="1"> <thead> <tr> <th>Value</th> <th>Description</th> </tr> </thead> <tbody> <tr> <td>0x1E</td> <td>0.3</td> </tr> <tr> <td>0x1F</td> <td>0.31</td> </tr> <tr> <td>0x20</td> <td>0.32</td> </tr> <tr> <td colspan="2">Continuing through...</td> </tr> <tr> <td>0x64</td> <td>1</td> </tr> <tr> <td>To...</td> <td></td> </tr> <tr> <td>0xBC</td> <td>1.88</td> </tr> <tr> <td>0xBD</td> <td>1.89</td> </tr> <tr> <td>0xBE</td> <td>1.9</td> </tr> </tbody> </table>	Value	Description	0x1E	0.3	0x1F	0.31	0x20	0.32	Continuing through...		0x64	1	To...		0xBC	1.88	0xBD	1.89	0xBE	1.9
Value	Description																					
0x1E	0.3																					
0x1F	0.31																					
0x20	0.32																					
Continuing through...																						
0x64	1																					
To...																						
0xBC	1.88																					
0xBD	1.89																					
0xBE	1.9																					

Table 55: BUCK_BUCK2_7 (0x002F)

Bit	Symbol	Description										
[3]	Reserved	Reserved										
[2]	Reserved	Reserved										
[1:0]	CH2_RIPPLE_CANCEL	<p>Ripple cancel control (can be used to improve output overshoot at heavy to light load transient).</p> <table border="1"> <thead> <tr> <th>Value</th> <th>Description</th> </tr> </thead> <tbody> <tr> <td>0x0</td> <td>No ripple cancel</td> </tr> <tr> <td>0x1</td> <td>Small ripple cancel</td> </tr> <tr> <td>0x2</td> <td>Mid ripple cancel</td> </tr> <tr> <td>0x3</td> <td>Large ripple cancel</td> </tr> </tbody> </table>	Value	Description	0x0	No ripple cancel	0x1	Small ripple cancel	0x2	Mid ripple cancel	0x3	Large ripple cancel
Value	Description											
0x0	No ripple cancel											
0x1	Small ripple cancel											
0x2	Mid ripple cancel											
0x3	Large ripple cancel											

High-Performance, Dual-Channel DC-DC Converter for Mobile and Portable Applications

5.1.4 Serialization

Table 56: OTP_DEVICE_ID (0x0048)

Bit	Symbol	Description
[7:0]	DEV_ID	Device ID

Table 57: OTP_VARIANT_ID (0x0049)

Bit	Symbol	Description
[7:4]	MRC	Mask Revision Code
[3:0]	VRC	Chip Variant Code

Table 58: OTP_CUSTOMER_ID (0x004A)

Bit	Symbol	Description
[7:0]	CUST_ID	Customer ID

Table 59: OTP_CONFIG_ID (0x004B)

Bit	Symbol	Description
[7:0]	CONFIG_REV	OTP Variant

High-Performance, Dual-Channel DC-DC Converter for Mobile and Portable Applications

6 Package Information

6.1 Package Outlines

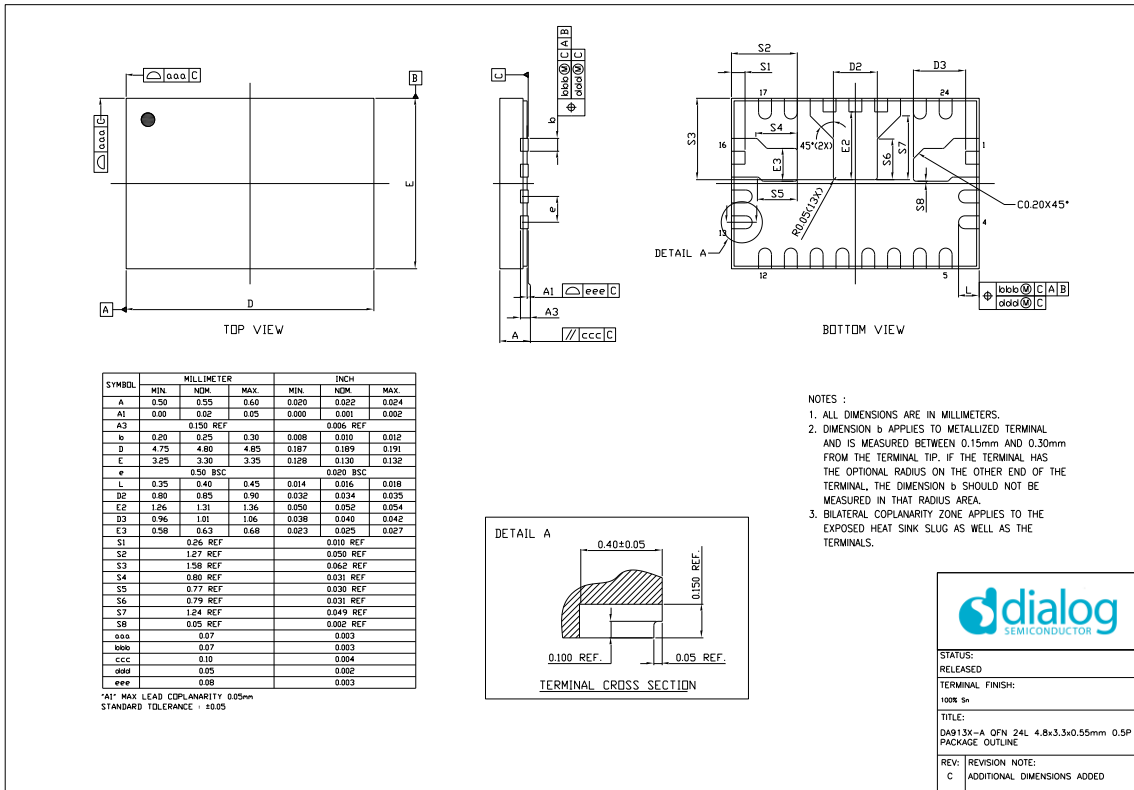

Figure 19: Package Outline Drawing

High-Performance, Dual-Channel DC-DC Converter for Mobile and Portable Applications

6.2 Package Marking

Package Marking		
A1 Corner >	Marking Content	Format
1st	•	Pin 1 ID
2nd	D A 9 1 3 2	Orientation/Part No.
3rd	x x A T y y	OTP/Option/Year
4th	W W Z Z Z Z	Date Code
Date Code Format: yy = Year, ww = Week, zzzz = Traceability		
xx identifies the OTP Variant		
A or AT optionally indicate the Automotive and Automotive high temp test options.		

6.3 Moisture Sensitivity Level

The moisture sensitivity level (MSL) is an indicator for the maximum allowable time period (floor lifetime) in which a moisture sensitive plastic device, once removed from the dry bag, can be exposed to an environment with a specified maximum temperature and a maximum relative humidity before the solder reflow process. The MSL classification is defined in [The FCQFN](#) package is qualified for MSL 3.

Table 60.

For detailed information on MSL levels refer to the IPC/JEDEC standard J-STD-020, which can be downloaded from <http://www.jedec.org>.

The FCQFN package is qualified for MSL 3.

Table 60: MSL Classification

MSL Level	Floor Lifetime	Conditions
MSL 4	72 hours	30 °C / 60 % RH
MSL 3	168 hours	30 °C / 60 % RH
MSL 2A	4 weeks	30 °C / 60 % RH
MSL 2	1 year	30 °C / 60 % RH
MSL 1	Unlimited	30 °C / 60 % RH

6.4 Soldering Information

Refer to the IPC/JEDEC standard J-STD-020 for relevant soldering information. This document can be downloaded from <http://www.jedec.org>.

High-Performance, Dual-Channel DC-DC Converter for Mobile and Portable Applications

7 Ordering Information

The ordering number consists of the part number followed by a suffix indicating the packing method. For details and availability, please consult your Dialog Semiconductor [local sales representative](#).

Table 61: Ordering Information

Part Number	Package	Package Description	MOQ
DA9132xxRT2	24 FCQFN wettable flanks, 3.3 x 4.8	T&R, 4800 pcs	3 Reels - 14400
DA9132xxRT1	24 FCQFN wettable flanks	Tray, 490 pcs	30 Trays - 14700 pcs

High-Performance, Dual-Channel DC-DC Converter for Mobile and Portable Applications

8 Application Information

The following recommended components are examples selected from requirements of a typical application.

8.1 Capacitor Selection

Ceramic capacitors are used as bypass capacitors at all VDD and output rails. When selecting a capacitor, especially for types with high capacitance at smallest physical dimension, the DC bias characteristic has to be taken into account.

Table 62: Recommended Consumer Grade Capacitor Types

Application	Value (µF)	Size	Temp. Char.	Tol. (%)	V-Rate (V)	Type
VOUT output bypass	10	0402	X5R	20	6.3	Murata GRM155R60J106ME15
PVDDx bypass	10	0603	X5R	20	25	Murata GRM188R61E106MA73
AVDD bypass	1	0402	X5R	10	10	Murata GRM155R61A105KE15

Table 63: Recommended Automotive Grade Capacitor Types

Application	Value (µF)	Size	Temp. Char.	Tol. (%)	V-Rate (V)	Type
VOUT output bypass	10	0805	X7R ±15%	±10	6.3	TDK CGA4J1X7R0J106K125AC
PVDDx bypass	10	3216	X7R ±15%	±10	16	Murata GCM31CR71C106KA64L
AVDD bypass	1	0805	X7R ±15%	±10	50	Murata GCM21BR71H105KA03L

8.2 Inductor Selection

Inductors should be selected based on the following parameters:

- Rated maximum current
Usually a coil provides two current limits: ISAT specifies the maximum current at which the inductance drops by 30 % of the nominal value, and IMAX is defined by the maximum power dissipation and is applied to the effective current.
- DC resistance
Critical for the converter efficiency and should therefore be minimized.

Table 64: Recommended Inductor Types

Value (µH)	Size (mm)	IMAX (DC) (A)	ISAT (A)	Tol. (%)	DC Resistance (mΩ)	Type
0.22	2.5 x 2.0 x 1.2	6.7	8	20	8	TDK TFM252012ALMAR22MTAA
0.47	2.5 x 2.0 x 1.2	4.9	5.8	20	8	TDK TFM252012ALMAR47MTAA

High-Performance, Dual-Channel DC-DC Converter for Mobile and Portable Applications

Status Definitions

Revision	Datasheet Status	Product Status	Definition
1.<n>	Target	Development	This datasheet contains the design specifications for product development. Specifications may be changed in any manner without notice.
2.<n>	Preliminary	Qualification	This datasheet contains the specifications and preliminary characterization data for products in pre-production. Specifications may be changed at any time without notice in order to improve the design.
3.<n>	Final	Production	This datasheet contains the final specifications for products in volume production. The specifications may be changed at any time in order to improve the design, manufacturing and supply. Major specification changes are communicated via Customer Product Notifications. Datasheet changes are communicated via www.dialog-semiconductor.com .
4.<n>	Obsolete	Archived	This datasheet contains the specifications for discontinued products. The information is provided for reference only.

Disclaimer

Unless otherwise agreed in writing, the Dialog Semiconductor products (and any associated software) referred to in this document are not designed, authorized or warranted to be suitable for use in life support, life-critical or safety-critical systems or equipment, nor in applications where failure or malfunction of a Dialog Semiconductor product (or associated software) can reasonably be expected to result in personal injury, death or severe property or environmental damage. Dialog Semiconductor and its suppliers accept no liability for inclusion and/or use of Dialog Semiconductor products (and any associated software) in such equipment or applications and therefore such inclusion and/or use is at the customer's own risk.

Information in this document is believed to be accurate and reliable. However, Dialog Semiconductor does not give any representations or warranties, express or implied, as to the accuracy or completeness of such information. Dialog Semiconductor furthermore takes no responsibility whatsoever for the content in this document if provided by any information source outside of Dialog Semiconductor.

Dialog Semiconductor reserves the right to change without notice the information published in this document, including, without limitation, the specification and the design of the related semiconductor products, software and applications. Notwithstanding the foregoing, for any automotive grade version of the device, Dialog Semiconductor reserves the right to change the information published in this document, including, without limitation, the specification and the design of the related semiconductor products, software and applications, in accordance with its standard automotive change notification process.

Applications, software, and semiconductor products described in this document are for illustrative purposes only. Dialog Semiconductor makes no representation or warranty that such applications, software and semiconductor products will be suitable for the specified use without further testing or modification. Unless otherwise agreed in writing, such testing or modification is the sole responsibility of the customer and Dialog Semiconductor excludes all liability in this respect.

Nothing in this document may be construed as a license for customer to use the Dialog Semiconductor products, software and applications referred to in this document. Such license must be separately sought by customer with Dialog Semiconductor.

All use of Dialog Semiconductor products, software and applications referred to in this document is subject to Dialog Semiconductor's [Standard Terms and Conditions of Sale](http://www.dialog-semiconductor.com), available on the company website (www.dialog-semiconductor.com) unless otherwise stated.

Dialog, Dialog Semiconductor and the Dialog logo are trademarks of Dialog Semiconductor Plc or its subsidiaries. All other product or service names and marks are the property of their respective owners.

© 2021 Dialog Semiconductor. All rights reserved.

RoHS Compliance

Dialog Semiconductor's suppliers certify that its products are in compliance with the requirements of Directive 2011/65/EU of the European Parliament on the restriction of the use of certain hazardous substances in electrical and electronic equipment. RoHS certificates from our suppliers are available on request.

Contact Dialog Semiconductor

General Enquiry:

[Enquiry Form](#)

Local Offices:

<https://www.dialog-semiconductor.com/contact/sales-offices>