

CBT-QFE DIRECT MOUNT, SOLDERLESS SOCKET FOR BURN-IN AND TEST APPLICATIONS

Features

- Wide temperature range (-55C to +155C).
- High current capability (up to 2.2 A).
- Excellent signal integrity at high frequencies.
- Low and stable contact resistance for reliable production yield.
- Highly compliant to accommodate wide co-planarity variations.
- Automated probe manufacturing enables low cost and short lead time.

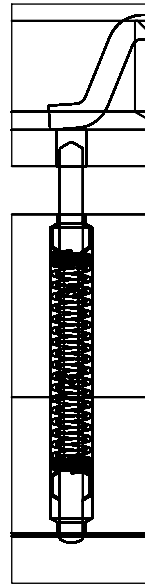
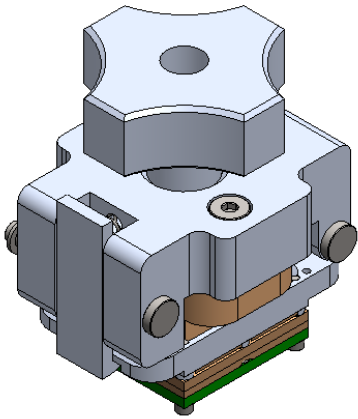

DETAIL L
SCALE 16 : 1

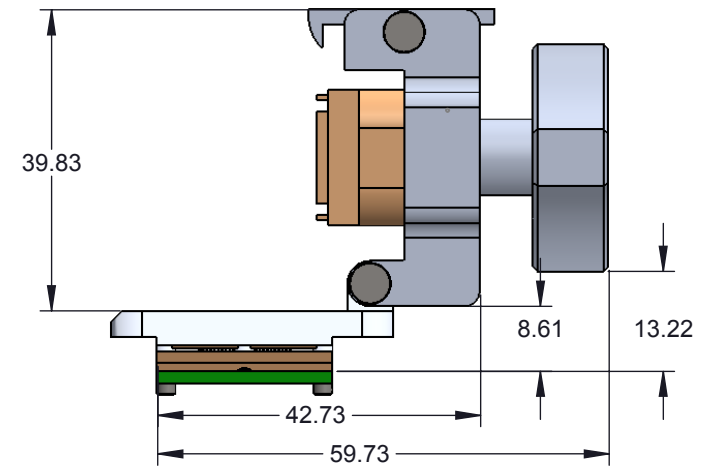
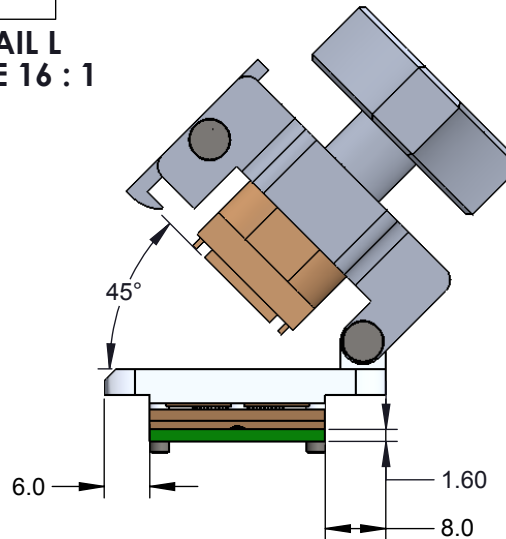
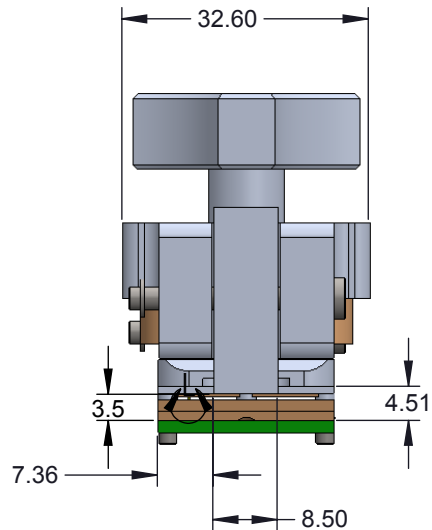

Description: CBT-QFE100SE 0.5mm Pitch 16-16mm T-T

Primary dimension units are millimeters, Secondary dimension units are [inches], Weight is in grams.

Tolerances: Hole diameters $\pm 0.03\text{mm}$ [$\pm 0.001"$], Pitches (from true position) $\pm 0.025\text{mm}$ [$\pm 0.001"$], substrate thickness tolerance $\pm 10\%$, all other tolerances $\pm 0.13\text{mm}$ [$\pm 0.005"$] unless stated otherwise. Materials and specifications are subject to change without notice.

 CBT-QFE-3000 Drawing Ironwood Electronics, Inc. Tele: (800) 404-0204 www.ironwoodelectronics.com	Material:	STATUS: Released	SHEET: 1 OF 4	REV. A
	Finish:	ENG: V. Panavala	DRAWN BY: V. Panavala	SCALE: 1:1
	Weight:	FILE: CBT-QFE-3000	DATE: 5/28/2013	

***Note: QFE pattern is not symmetrical with respect to the mounting holes.**

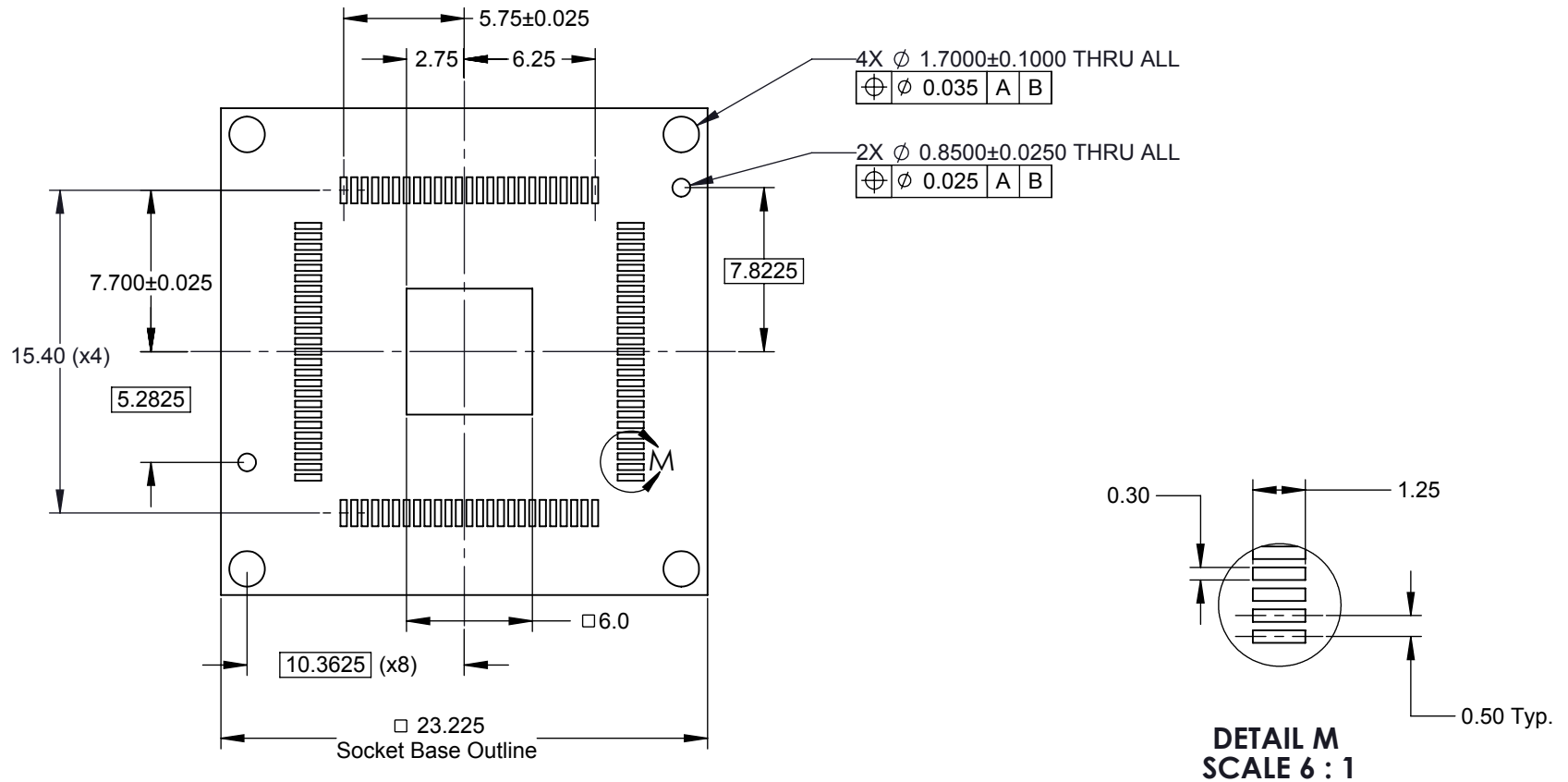

Description: Recommended PCB layout

Primary dimension units are millimeters, Secondary dimension units are [inches], Weight is in grams.

Tolerances: Hole diameters $\pm 0.03\text{mm}$ [± 0.001 "], Pitches (from true position) $\pm 0.025\text{mm}$ [± 0.001 "], substrate thickness tolerance $\pm 10\%$, all other tolerances $\pm 0.13\text{mm}$ [± 0.005 "] unless stated otherwise. Materials and specifications are subject to change without notice.

Target PCB Recommendations

Total thickness: 1.6mm min.

Plating: Gold or Solder finish

PCB Pad height: same or higher than solder mask

 CBT-QFE-3000 Drawing Ironwood Electronics, Inc. Tele: (800) 404-0204 www.ironwoodelectronics.com	Material: Finish: Weight:	STATUS: Released	SHEET: 2 OF 4	REV. A
		ENG: V. Panavala	DRAWN BY: V. Panavala	SCALE: 3:1
		FILE: CBT-QFE-3000	DATE: 5/28/2013	

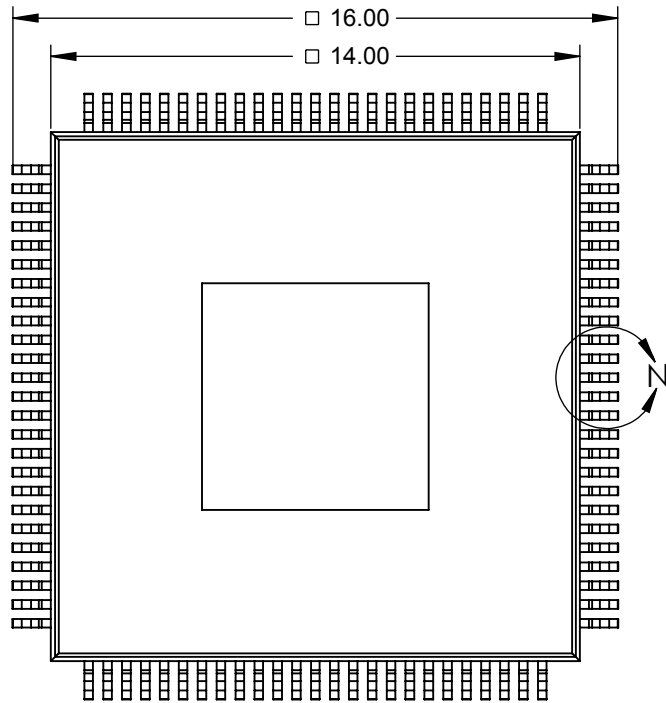

Ironwood Package codes accommodated					
Pkg. Code	Pins	Pitch	Body Size	Tip to tip	foot length
QFE100SE	100	0.5mm	14 mm x 14 mm	16 mm x 16 mm	0.6mm

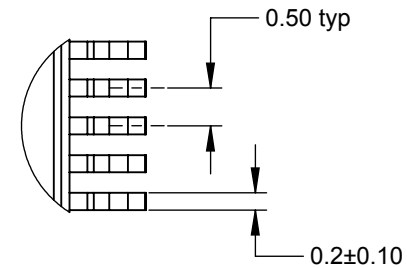

DETAIL N
SCALE 10 : 1

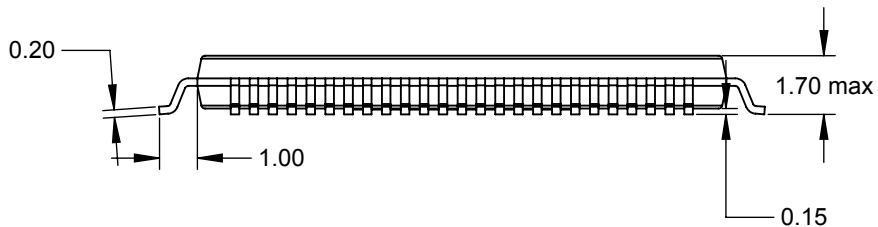

Description: QFE100 TEST CHIP

Primary dimension units are millimeters, Secondary dimension units are [inches], Weight is in grams.

Tolerances: Hole diameters $\pm 0.03\text{mm}$ [$\pm 0.001"$], Pitches (from true position) $\pm 0.025\text{mm}$ [$\pm 0.001"$], substrate thickness tolerance $\pm 10\%$, all other tolerances $\pm 0.13\text{mm}$ [$\pm 0.005"$] unless stated otherwise. Materials and specifications are subject to change without notice.

 CBT-QFE-3000 Drawing Ironwood Electronics, Inc. Tele: (800) 404-0204 www.ironwoodelectronics.com	Material: Finish: Weight:	STATUS: Released	SHEET: 3 OF 4	REV. A
		ENG: V. Panavala	DRAWN BY: V. Panavala	SCALE: 5:1
		FILE: CBT-QFE-3000	DATE: 5/28/2013	

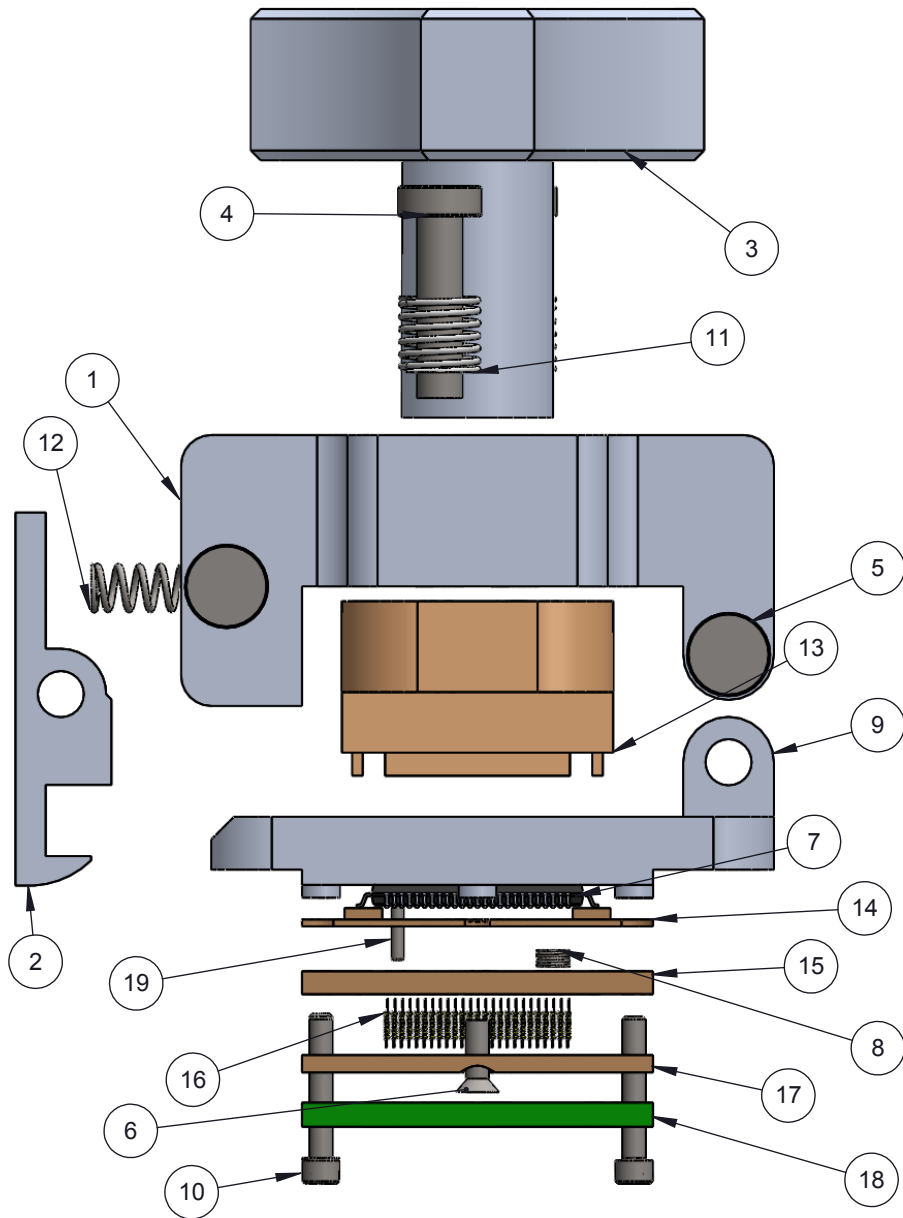

ITEM NO.	Description	Material
1	Clam shell lid for 17mm IC	7075-T6 Aluminum Alloy
2	Clamshell Latch	7075-T6 Aluminum Alloy
3	M10 Compression Screw with hole	7075-T6 Aluminum Alloy
4	Screw, M3 x 12mm, Low Head Cap, SS	18-8 Stainless Steel
5	Hinge Pin and Snap Ring, 3mm OD, 25mm long, SS	Stainless Steel (ferritic)
6	Screw, #0-80 X .188", Flat, SS	Stainless Steel (18-8)
7	QFE100SE chip	
8	Floating Guide Spring	Alloy Steel (SS)
9	CBT Socket Base 18mm W posts	7075-T6 Aluminum Alloy
10	#0-80 X .375 LG, SOC HD CAP SCREW, ALLOY STL, BLK OXIDE	Alloy Steel
11	Spring Clamshell lid assembly	Steel Music Wire
12	Precision Compression Spring, Zinc-Plated Music Wire, 1/2" Length, .12" OD, .016" Wire	Zinc Plated Music Wire
13	QFE100 clashell socket compression Plate; 18mm	Ultem
14	CBT-QFE100SE Floating spring pin guide	Semitron MDS 100
15	Middle guide QFE100SE 16x16mm T-T	Semitron MDS 100
16	SBT Pin, 0.4mm pitch	N/A
17	Bottom CBT pin guide QFE100SE	Semitron MDS 100
18	QFE100SE PCB	Material <not specified>
19	Dowel pin, 1/32" X 1/4", SS	Stainless Steel (18-8)

Instructions:

- Drop the QFE package in the socket and make sure the QFE leads are sitting inside the guide slots of the floating guide(item14)
- Turn the fluted knob screw(item 3) until it contacts the QFE chip.
- From that point screw needs four turns to get the desired compression. Or Turn the fluted knob(item 3) screw until the floating guide(item 14) bottoms out on the Middle guide(item 15)

Description: Socket Spec

Primary dimension units are millimeters, Secondary dimension units are [inches], Weight is in grams.

Tolerances: Hole diameters $\pm 0.03\text{mm}$ [$\pm 0.001"$], Pitches (from true position) $\pm 0.025\text{mm}$ [$\pm 0.001"$], substrate thickness tolerance $\pm 10\%$, all other tolerances $\pm 0.13\text{mm}$ [$\pm 0.005"$] unless stated otherwise. Materials and specifications are subject to change without notice.

 CBT-QFE-3000 Drawing Ironwood Electronics, Inc. Tele: (800) 404-0204 www.ironwoodelectronics.com	Material: Finish: Weight:	STATUS: Released	SHEET: 4 OF 4	REV. A
		ENG: V. Panavala	DRAWN BY: V. Panavala	SCALE: 5:1
		FILE: CBT-QFE-3000	DATE: 5/28/2013	