



7N60

Power MOSFET

7.4A, 600V N-CHANNEL POWER MOSFET

■ DESCRIPTION

The UTC **7N60** is a high voltage power MOSFET and is designed to have better characteristics, such as fast switching time, low gate charge, low on-state resistance and have a high rugged avalanche characteristics. This power MOSFET is usually used at high speed switching applications in switching power supplies and adaptors.

■ FEATURES

- * $R_{DS(ON)} = 1.0\Omega @V_{GS} = 10V$ (7N60)
- $R_{DS(ON)} = 1.2\Omega @V_{GS} = 10V$ (7N60-F/7N60-M/7N60-R /7N60-Q)
- * Ultra Low Gate Charge (Typical 29 nC)
- * Low Reverse Transfer Capacitance ($C_{RSS} =$ typical 16pF)
- * Fast Switching Capability
- * Avalanche Energy Tested
- * Improved dv/dt Capability, High Ruggedness

■ SYMBOL

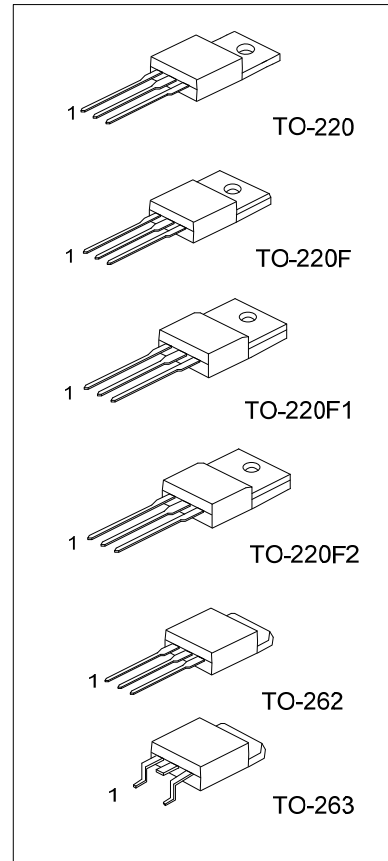
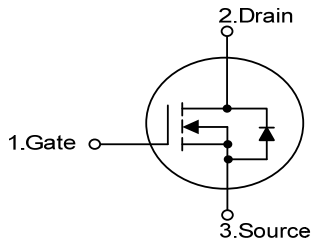

■ ORDERING INFORMATION

Ordering Number		Package	Pin Assignment			Packing
Lead Free	Halogen Free		1	2	3	
7N60L-TA3-T	7N60G-TA3-T	TO-220	G	D	S	Tube
7N60L-TF3-T	7N60G-TF3-T	TO-220F	G	D	S	Tube
7N60L-TF1-T	7N60G-TF1-T	TO-220F1	G	D	S	Tube
7N60L-TF2-T	7N60G-TF2-T	TO-220F2	G	D	S	Tube
7N60L-T2Q-T	7N60G-T2Q-T	TO-262	G	D	S	Tube
7N60L-TQ2-R	7N60G-TQ2-R	TO-263	G	D	S	Tape Reel
7N60L-TQ2-T	7N60G-TQ2-T	TO-263	G	D	S	Tube

Note: Pin Assignment: G: Gate D: Drain S: Source

<p>7N60L-TA3-T</p> <p>(1) Packing Type (2) Package Type (3) Lead Free</p>	<p>(1) R: Tape Reel, T: Tube (2) TA3: TO-220, TF1: TO-220F1, TF3: TO-220F T2Q: TO-262, TQ2: TO-263, TF2: TO-220F2 (3) G: Halogen Free, L: Lead Free</p>
---	---

■ ABSOLUTE MAXIMUM RATINGS ($T_C = 25^\circ\text{C}$, unless otherwise specified)

PARAMETER		SYMBOL	RATINGS	UNIT
Drain-Source Voltage		V_{DSS}	600	V
Gate-Source Voltage		V_{GSS}	± 30	V
Avalanche Current (Note 2)		I_{AR}	7.4	A
Drain Current	Continuous	I_D	7.4	A
	Pulsed (Note 2)	I_{DM}	29.6	A
Avalanche Energy	Single Pulsed (Note 3)	E_{AS}	530	mJ
	Repetitive (Note 2)	E_{AR}	14.2	mJ
Peak Diode Recovery dv/dt (Note 4)		dv/dt	4.5	V/ns
Power Dissipation	TO-220/TO-262/TO-263	P_D	142	W
	TO-220F/TO-220F1		48	
	TO-220F2		50	
Junction Temperature		T_J	+150	$^\circ\text{C}$
Storage Temperature		T_{STG}	-55 ~ +150	$^\circ\text{C}$

Notes: 1. Absolute maximum ratings are those values beyond which the device could be permanently damaged.

Absolute maximum ratings are stress ratings only and functional device operation is not implied.

2. Repetitive Rating : Pulse width limited by maximum junction temperature

3. $L = 19.5\text{mH}$, $I_{AS} = 7.4\text{A}$, $V_{DD} = 50\text{V}$, $R_G = 25\ \Omega$, Starting $T_J = 25^\circ\text{C}$

4. $I_{SD} \leq 7.4\text{A}$, $di/dt \leq 200\text{A}/\mu\text{s}$, $V_{DD} \leq BV_{DSS}$, Starting $T_J = 25^\circ\text{C}$

■ THERMAL DATA

PARAMETER		SYMBOL	RATINGS	UNIT
Junction to Ambient		θ_{JA}	62.5	$^\circ\text{C}/\text{W}$
Junction to Case	TO-220/TO-262/TO-263	θ_{JC}	0.88	$^\circ\text{C}/\text{W}$
	TO-220F/TO-220F1		2.6	
	TO-220F2		2.5	

■ ELECTRICAL CHARACTERISTICS (T_C=25°C, unless otherwise specified)

PARAMETER	SYMBOL	TEST CONDITIONS	MIN	TYP	MAX	UNIT
OFF CHARACTERISTICS						
Drain-Source Breakdown Voltage	BV _{DSS}	V _{GS} = 0V, I _D = 250μA	600			V
Drain-Source Leakage Current	I _{DSS}	V _{DS} = 600V, V _{GS} = 0V			1	μA
Gate- Source Leakage Current	Forward	I _{GSS}	V _{GS} = 30V, V _{DS} = 0V		100	nA
	Reverse		V _{GS} = -30V, V _{DS} = 0V		-100	nA
Breakdown Voltage Temperature Coefficient	ΔBV _{DSS} /ΔT _J	I _D =250μA, Referenced to 25°C		0.67		V/°C
ON CHARACTERISTICS						
Gate Threshold Voltage	V _{GS(TH)}	V _{DS} = V _{GS} , I _D = 250μA	2.0		4.0	V
Static Drain-Source On-State Resistance	R _{DS(ON)}	V _{GS} = 10V, I _D = 3.7A	7N60	0.83	1.0	Ω
			7N60-F	0.93	1.2	Ω
			7N60-M	0.93	1.2	Ω
			7N60-Q	0.93	1.2	Ω
			7N60-R	0.93	1.2	Ω
DYNAMIC CHARACTERISTICS						
Input Capacitance	C _{ISS}	V _{DS} =25V, V _{GS} =0V, f=1.0 MHz			1400	pF
Output Capacitance	C _{OSS}				180	pF
Reverse Transfer Capacitance	C _{RSS}			16	21	pF
SWITCHING CHARACTERISTICS						
Turn-On Delay Time	t _{D(ON)}	V _{DD} = 300V, I _D = 7.4A, R _G = 25Ω (Note 1, 2)			70	ns
Turn-On Rise Time	t _R				170	ns
Turn-Off Delay Time	t _{D(OFF)}				140	ns
Turn-Off Fall Time	t _F				130	ns
SWITCHING CHARACTERISTICS						
Total Gate Charge	Q _G	V _{DS} =480V, I _D =7.4A, V _{GS} =10V (Note 1, 2)		29	38	nC
Gate-Source Charge	Q _{GS}			7		nC
Gate-Drain Charge	Q _{GD}			14.5		nC
DRAIN-SOURCE DIODE CHARACTERISTICS AND MAXIMUM RATINGS						
Drain-Source Diode Forward Voltage	V _{SD}	V _{GS} = 0V, I _S = 7.4 A			1.4	V
Maximum Continuous Drain-Source Diode Forward Current	I _S				7.4	A
Maximum Pulsed Drain-Source Diode Forward Current	I _{SM}				29.6	A
Reverse Recovery Time	t _{rr}	V _{GS} = 0V, I _S = 7.4 A,		320		ns
Reverse Recovery Charge	Q _{RR}	dI _F / dt = 100A/μs (Note 1)		2.4		μC

- Notes: 1. Pulse Test: Pulse width ≤ 300μs, Duty cycle ≤ 2%
2. Essentially independent of operating temperature

■ CLASSIFICATION OF R_{DS(ON)}

RANK	-	F	M	Q	R
VALUE	1.0Ω	1.2Ω	1.2Ω	1.2Ω	1.2Ω

■ TEST CIRCUITS AND WAVEFORMS

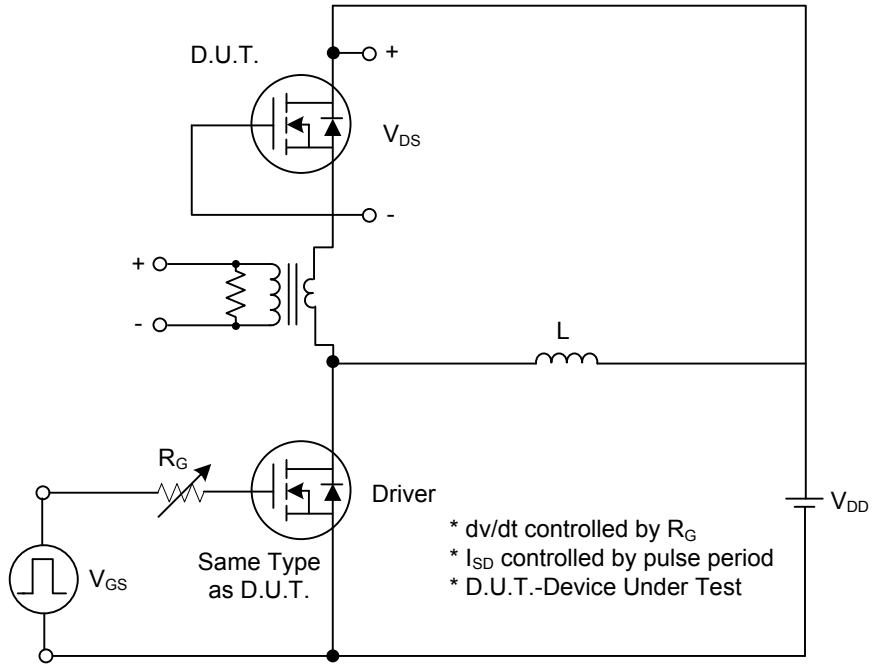

Peak Diode Recovery dv/dt Test Circuit

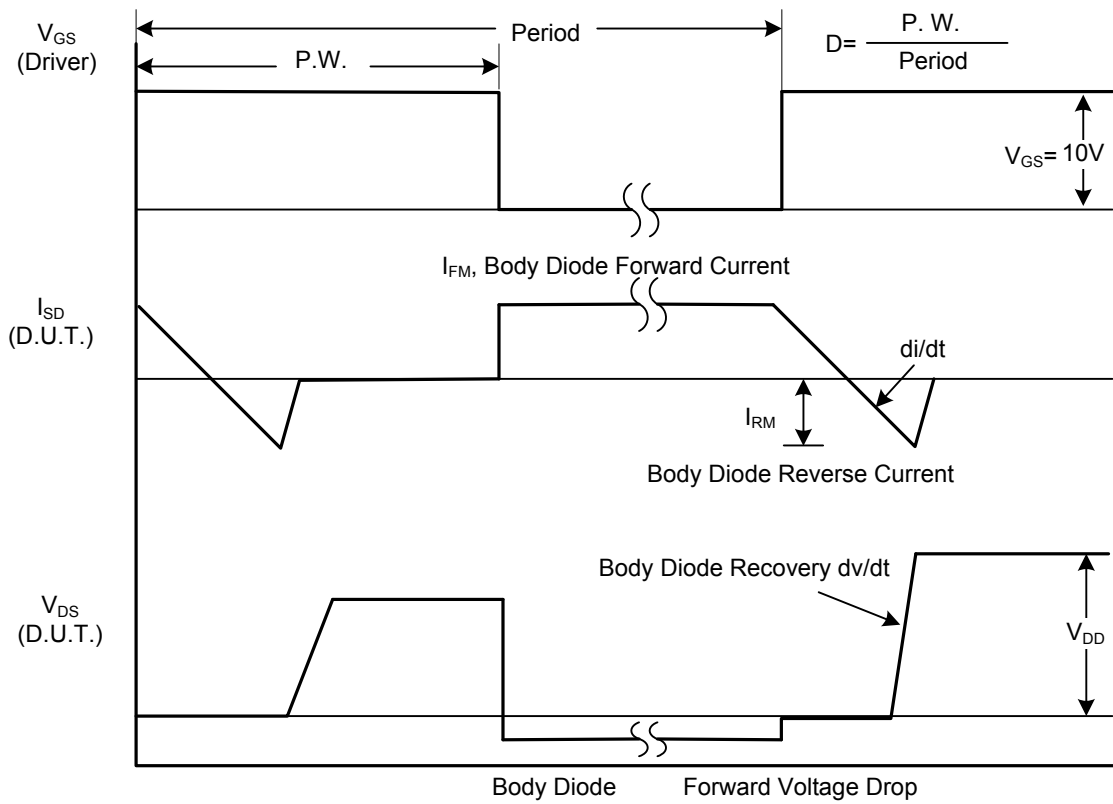

Peak Diode Recovery dv/dt Waveforms

■ TEST CIRCUITS AND WAVEFORMS (Cont.)

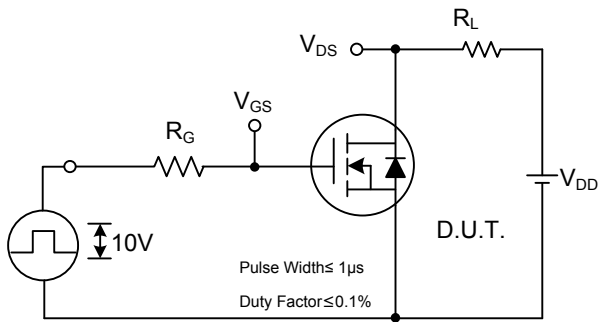

Switching Test Circuit

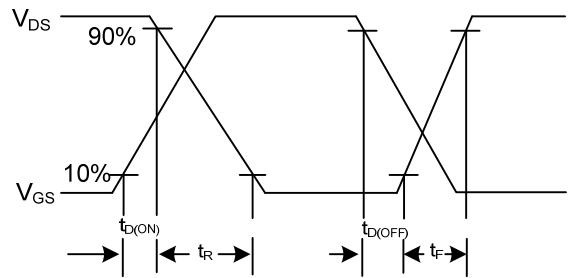

Switching Waveforms

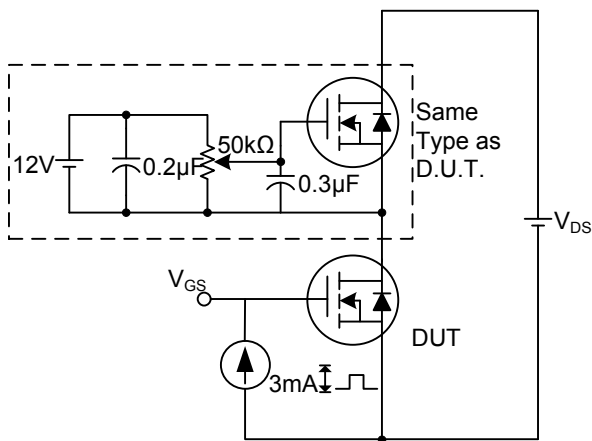

Gate Charge Test Circuit

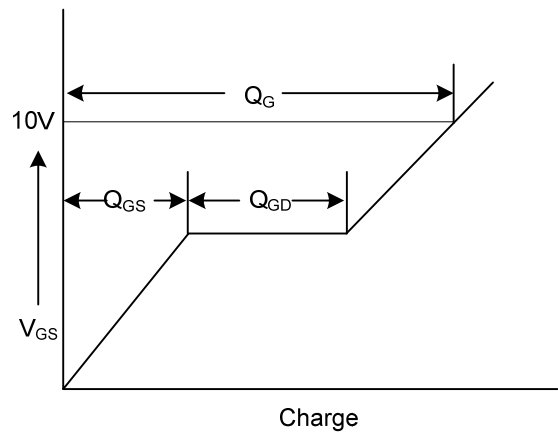

Gate Charge Waveform

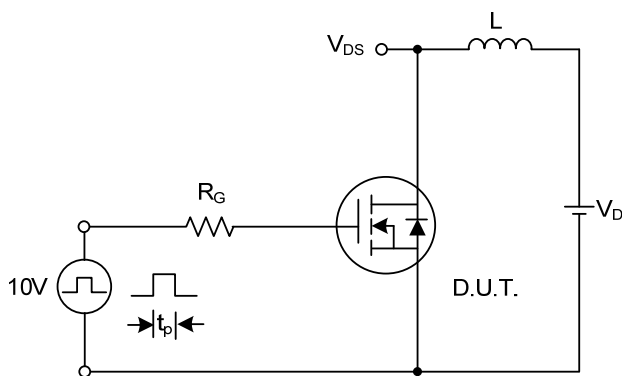

Unclamped Inductive Switching Test Circuit

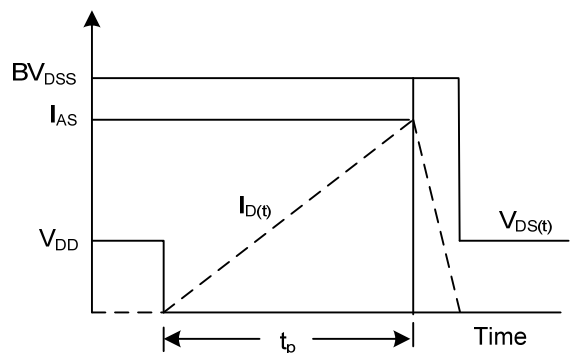

Unclamped Inductive Switching Waveforms

UTC assumes no responsibility for equipment failures that result from using products at values that exceed, even momentarily, rated values (such as maximum ratings, operating condition ranges, or other parameters) listed in products specifications of any and all UTC products described or contained herein. UTC products are not designed for use in life support appliances, devices or systems where malfunction of these products can be reasonably expected to result in personal injury. Reproduction in whole or in part is prohibited without the prior written consent of the copyright owner. The information presented in this document does not form part of any quotation or contract, is believed to be accurate and reliable and may be changed without notice.