

# IPC-7220

## Desktop/wallmount Chassis for ATX/mATX Motherboard



### Features

- Two 5.25" and two 3.5" shock-resistant drive bays
- Lockable front door to prevent unauthorized access
- LED indicators and alarm notification for system fault detection
- Easy-to-maintain system fan and air filter
- Low noise system fan
- Built-in Intelligent System Module enables whole system fan control and remote manageability

Quiet

CE FCC RoHS

### Specifications

		External	Internal
Drive Bay	5.25"	2	-
	3.5"	1	1
Cooling	Fan	1 (12 cm / 85 CFM)	
	Air Filters	2 (one 7 x 12 cm and one 12 x 12 cm)	
	Smart Fan	System fan speed referring to chassis thermal sensor, or CPU temperature (Available with selected Advantech MBs/CPU cards)	
Front I/O Interface	USB 2.0	2	
	PS/2	PS/2 keyboard and mouse, or PS/2 keyboard depends on the enclosed motherboard	
Miscellaneous	LED Indicators	Power, HDD, temperature and fan	
	Control	Power switch, system reset and alarm reset buttons	
	Rear Panel	Reserved Two 9-pin D-Sub openings, one LPT opening	
Intelligent System Module Remote Monitoring	CPU/System fan speed , CPU/System temperature , motherboard voltage (Only selected Advantech MBs/CPU cards with SUSIAccess installed can fully enable these functions, check with Advantech local rep. for detailed information.)		
Environmental	Temperature	Operating 0 ~ 40° C (32 ~ 104° F)	Non-Operating -20 ~ 60° C (-4 ~ 140° F)
	Humidity	10 ~ 85% @ 40° C, non-condensing	
	Vibration (5 ~ 500 Hz)	1 Grms	2 G
	Shock	10 G (with 11 ms duration, half sine wave)	30 G
	Physical Characteristics	Dimensions (W x H x D)	200 x 320 x 480 mm (7.9" x 12.6" x 18.9")
	Weight	14 kg (30.8 lb)	

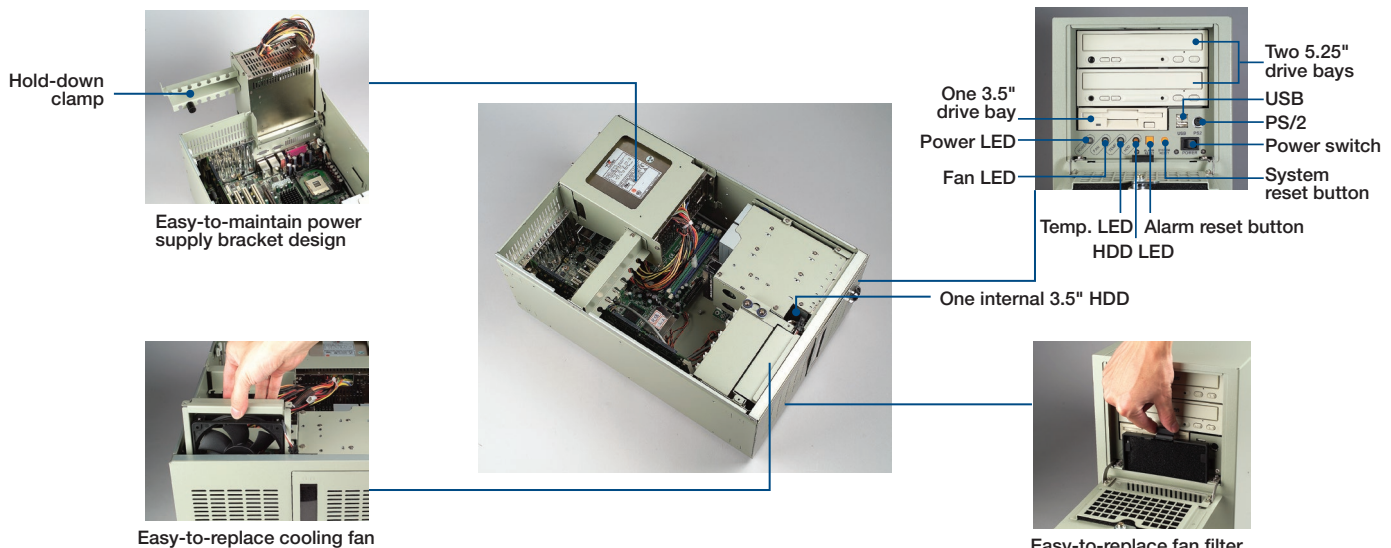

## Dimensions

Unit: mm [inch]

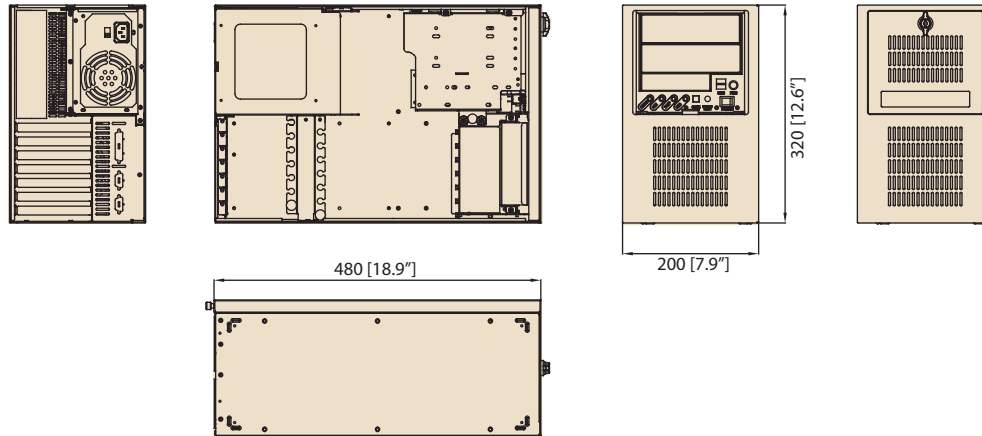

## Installation

Unit: mm [inch]

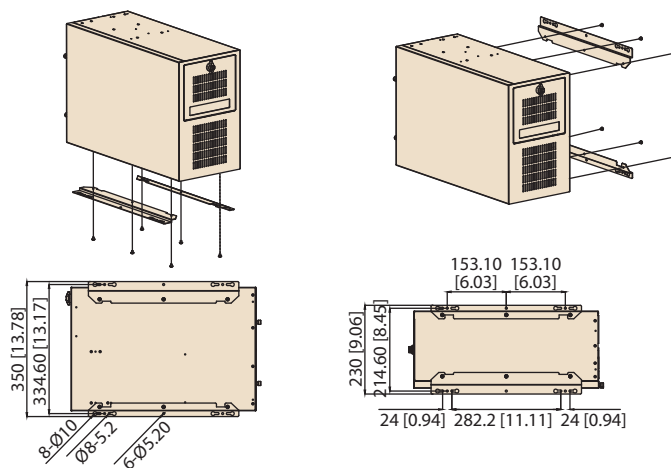

## Ordering Information

Model Name	Description
IPC-7220-00BE	Without power supply, with ATX switch
IPC-7220-30BE	With 300W power supply and ATX switch
IPC-7220-40BE	With 400W power supply and ATX switch

## Optional Accessories

Part Number	Description
IDT-3120E	Mobile rack for converting a 3.5" drive bay to dual 2.5" SATA HDD trays
IDT-5230E	Mobile rack for converting dual 5.25" drive bays to three 2.5" or 3.5" SAS/SATA HDD trays

## Power Supply Options

Part Number	80 Plus Grade	Wattage	Type	Input
PS8-300ATX-ZBE	Bronze	300W	Single	AC 100 ~ 240 V (full-range)
PS8-400ATX-ZE	Bronze	400W	Single	AC 100 ~ 240 V (full-range)