

DCS Input/Output Relay Card Series	
<b>I/O RELAY CARD</b> (with loopback test function)	MODEL <b>38N</b>

The 38N series I/O Relay Cards easily and quickly standardize and facilitate installation of the DCS relay board. Loopback test function simplifies startup and maintenance. The Standard Rack (Nest) model 38N can accept at the maximum of 16 channels of inputs and outputs.

- Input and output on one card
- Output ON/OFF switch and LED indicating relay status
- Test switch provided for checking DCS operation
- Fuse provided to each channel for electromagnetic valve
- Output current capacity 3A
- Output can be jumper selectable: voltage output for electromagnetic valve or dry contact output.

**< STANDARD RACK (nest) >**

**MODEL & SUFFIX CODE SELECTION**

**38N-B□□**

MODEL \_\_\_\_\_

CONNECTOR \_\_\_\_\_

H1 : Hitachi DCS connector

Y1 : Yokogawa KS2 cable use connector

OPTIONS \_\_\_\_\_

**Mounting**

: Rack mounting, standard (blank)

**/W** : Surface mounting

**TERMINAL CONNECTION**

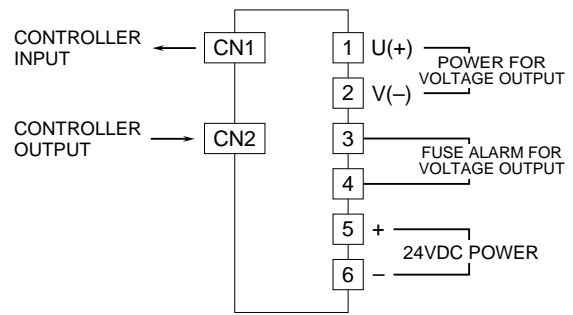

**ORDERING INFORMATION**

Specify code number. (e.g. 38N-BH1)

**GENERAL SPECIFICATIONS**

- Construction:** metal plates assembly; angle bracket mounting; JIS or EIA standard rack
- Capacity:** 16 positions
- Painting:** black
- Power input:** supplied to I/O cards collectively
- Output:** front accessed DCS connector and screw terminals; one fuse alarm output for all 16 channels
- Screw terminal material:** nickel-plated brass (torque 0.8 N·m)

**MOUNTING REQUIREMENTS mm (inch)**

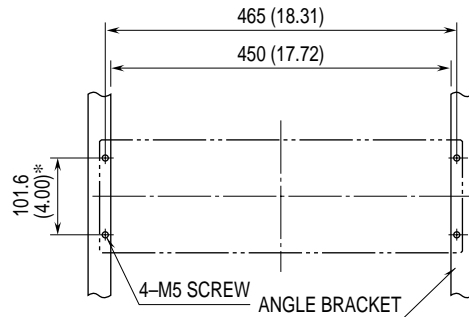

Observe an appropriate wiring space below.  
\*100 (3.94) for JIS standard

**INSTALLATION**

- Power input:** 24V DC ±10% (ripple 10% p-p max.)
- Operating temperature:** -5 to +55°C (23 to 131°F)
- Operating humidity:** 30 to 90% RH (non-condensing)
- Mounting:** rack or surface
- Dimensions:** W480×H149×D131 mm  
(18.90"×5.87"×5.16")
- Weight:** 2.5 kg (5.5 lbs)

**PERFORMANCE**

- Insulation resistance:** ≥100MΩ with 500V DC
- Dielectric strength:** 1000V AC @1 minute

**EXTERNAL DIMENSIONS mm (inch)**

■RACK (standard)

■SURFACE (option /W)

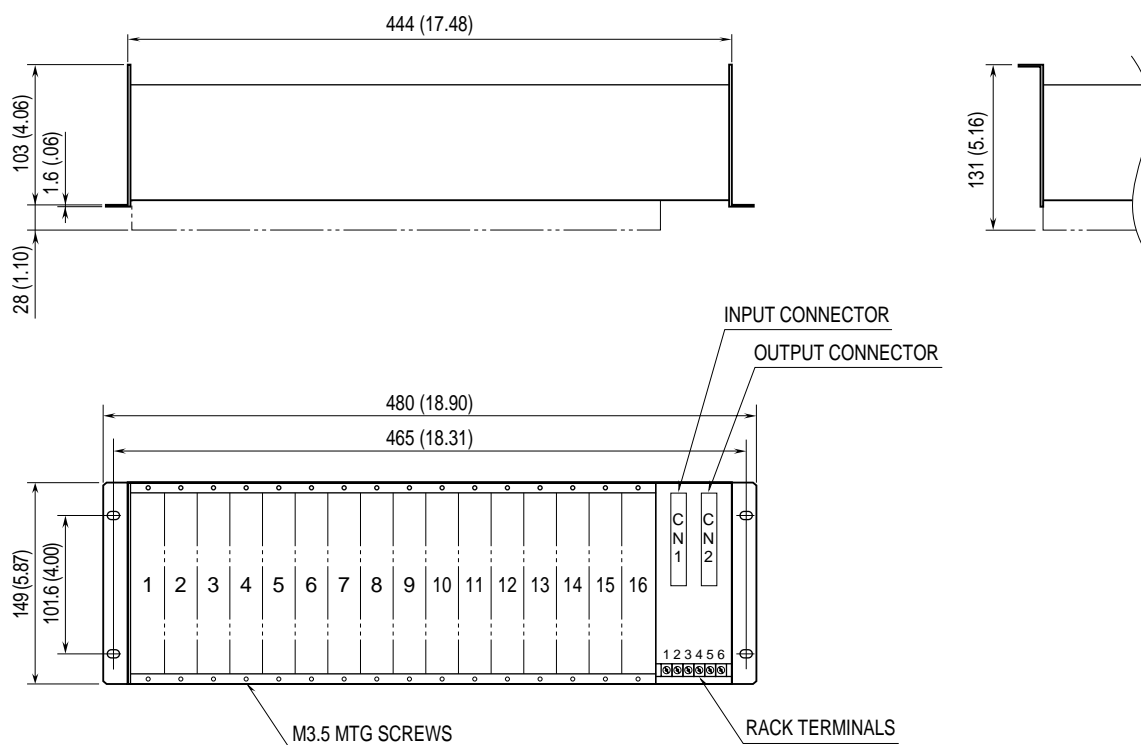

**HITACHI DCS**

■38N-BH1: Hitachi DCS connector  
Amphenol 57, 36-pin

•Connector Pin Assignments

CN1: input  
CN2: output

PIN NO.	ASSIGNMENT	PIN NO.	ASSIGNMENT
1	ch. 1 +	9	ch. 9 +
2	ch. 2 +	10	ch.10 +
3	ch. 3 +	11	ch.11 +
4	ch. 4 +	12	ch.12 +
5	ch. 5 +	13	ch.13 +
6	ch. 6 +	14	ch.14 +
7	ch. 7 +	15	ch.15 +
8	ch. 8 +	16	ch.16 +
19	COM -	27	COM -

17, 18, 20 - 26, 28 - 36: Unused

Pin assignments are the same for both CN1 and CN2.

**YOKOGAWA DCS**

■38N-BY1: Yokogawa DCS connector  
PS-40PE-D4LT1-PN1

•Location for ST card

CN1: input (KS2 cable use)  
CN2: output (KS2 cable use)

38-RACK LOCATION NO.															
1	2	3	4	5	6	7	8	9	10	11	12	13	14	15	16
1	2	3	4	5	6	7	8	9	10	11	12	13	14	15	16
ST2 / ST3 / ST4 CARD INPUT / OUTPUT NO.															

Pin assignments are the same for both CN1 and CN2.

## < LOOPBACK I/O RELAY CARD >

### **DISCONTINUED MODEL**

**Replaced with Model 38N2-2**

#### MODEL & SUFFIX CODE SELECTION

**38N-2**

**MODEL** \_\_\_\_\_

**INPUT**  
Dry contact or open collector

**OUTPUT**  
Voltage or dry contact (jumper selectable)

**FUNCTION** \_\_\_\_\_

**2** : Test circuit

#### ORDERING INFORMATION

Specify code number. (e.g. 38N-2)

#### GENERAL SPECIFICATIONS

**Construction:** rack mounted; terminal access via screw terminals at the front and via connector at the rear

**Connection**

- Input:** M3.5 screw terminals
- DCS I/O:** card-edge connector
- Output:** M3.5 screw terminals
- Power input:** supplied from card-edge connector

**Screw terminal material:** nickel-plated steel (torque 0.8 N·m)

**Fuse:** 0.5A

**Alarm contact:** dry contact output at the screw terminal when the fuse is blown

**Isolation:** input or power to output

**Test switch:** LED provided

#### INPUT

■ **CONTACT INPUT:** dry contact or open collector  
**Contact detecting:** 24V DC, approx. 20mA

■ **DCS STATUS OUTPUT:** dry contact or open collector  
**Contact detecting:** 24V DC, approx. 20mA

#### OUTPUT

■ **ELECTROMAGNETIC VALVE:** voltage contact

**Rated load:** 120V AC @0.5A (cosφ=1)

24V DC @0.5A (resistive load)

**Load current:** 8A max. for the total of 16 channels

■ **DRY CONTACT:** dry contact (electromagnetic valve or dry contact selectable with the jumper on the PCB)

**Rated load:** 120V AC @3A (cosφ=1)

24V DC @3A (resistive load)

**Relay protection:** For maximum relay life with inductive loads (e.g. coil), external protection including noise quenching is recommended.

■ **DCS STATUS INPUT:** relay contact

**Rated load:** 30V DC @3A (resistive load)

#### INSTALLATION

**Power input:** 24V DC ±10%, approx. 35mA

(ripple 10% p-p max.)

**Operating temperature:** -5 to +55°C (23 to 131°F)

**Operating humidity:** 30 to 90% RH (non-condensing)

**Mounting:** Standard Rack 38N-B□

**Dimensions:** W23×H149×D102 mm

(0.91"×5.87"×4.02")

**Weight:** 150 g (0.33 lbs)

#### PERFORMANCE

**Insulation resistance:** ≥100MΩ with 500V DC

**Dielectric strength:** 1000V AC @1 minute

**Relay life:** mechanical life 5 × 10<sup>7</sup> cycles

electrical life 10<sup>5</sup> cycles

(30 cycles/min. at rated load)

#### FRONT VIEW mm (inch)

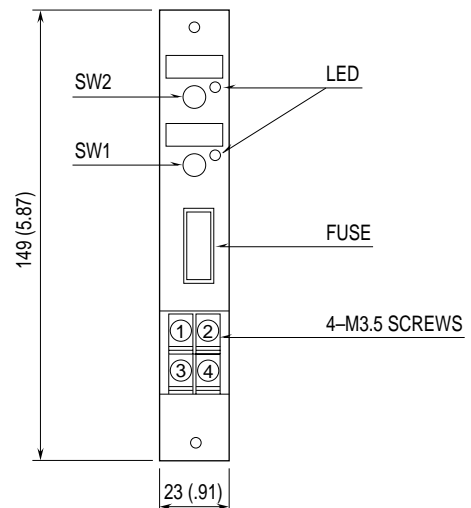

**OPERATIONS**

INPUT				OUTPUT					
SW2 STATUS	SW1 STATUS	DCS OUTPUT	INPUT	LED (IN)	DCS INPUT		LED (OUT)	OUTPUT	
					CONTACT A*	CONTACT B*			
DCS	DCS	ON	ON	ON	ON	ON	ON	ON	
		OFF	ON	ON	ON	ON	OFF	OFF	
		ON	OFF	OFF	OFF	OFF	OFF	ON	ON
		OFF	OFF	OFF	OFF	OFF	OFF	ON	ON
	ON	ON	ON / OFF	ON / OFF	ON	ON	ON	ON	ON
		OFF	ON / OFF	ON / OFF	ON	ON	ON	OFF	OFF
TEST	ON	ON / OFF	ON / OFF	ON	ON	OFF	OFF	OFF	
	OFF	ON / OFF	ON / OFF	OFF	OFF	ON	OFF	OFF	
OFF	N/A						OFF	OFF	
ON	N/A						ON	ON	

\*Selectable with a jumper.

**SCHEMATIC CIRCUITRY & CONNECTION DIAGRAM**

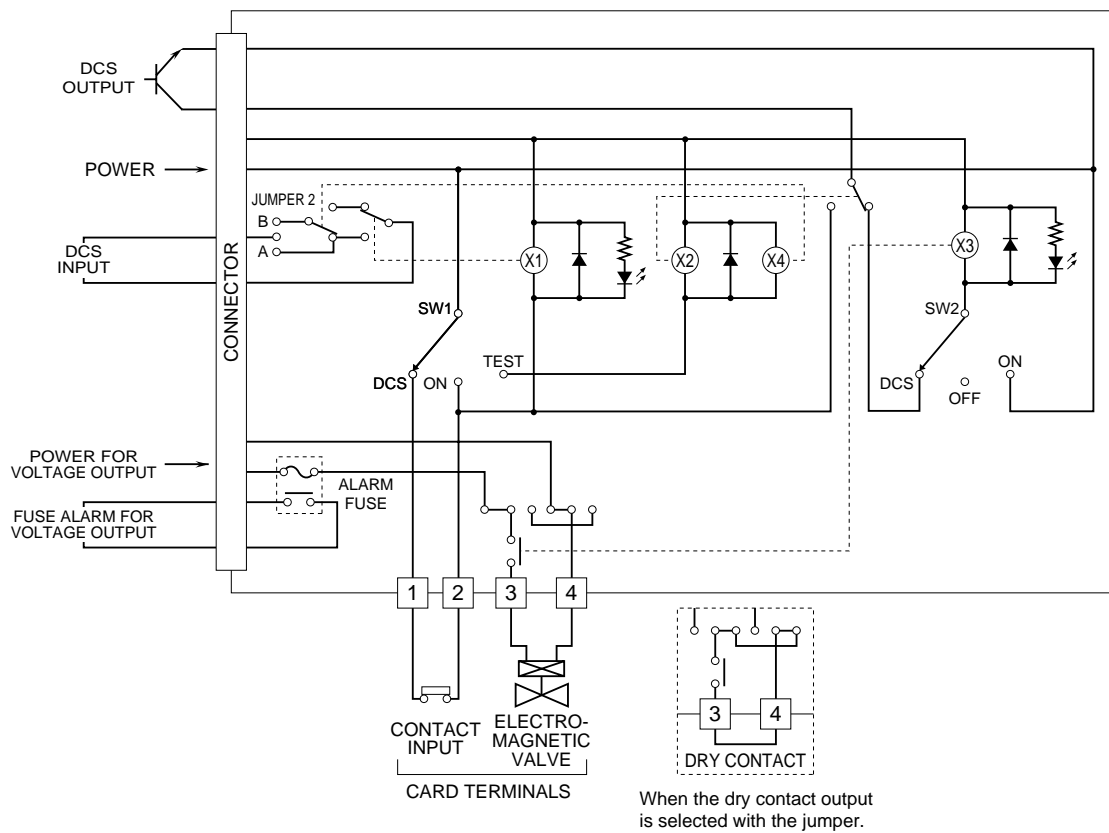

## < LOOPBACK I/O RELAY CARD >

### MODEL & SUFFIX CODE SELECTION

**38N2-2**

**MODEL** \_\_\_\_\_

**INPUT**  
Dry contact or open collector

**OUTPUT**  
Voltage or dry contact (jumper selectable)

**FUNCTION** \_\_\_\_\_

**2** : Test circuit

### ORDERING INFORMATION

Specify code number. (e.g. 38N2-2)

### GENERAL SPECIFICATIONS

**Construction:** rack mounted; terminal access via screw terminals at the front and via connector at the rear

#### Connection

**Input:** M3.5 screw terminals  
**DCS I/O:** card-edge connector  
**Output:** M3.5 screw terminals  
**Power input:** supplied from card-edge connector  
**Screw terminal material:** nickel-plated steel (torque 0.8 N·m)

**Fuse:** 0.5A

**Alarm contact:** dry contact output at the screw terminal when the fuse is blown

**Isolation:** DCS input to power or DCS output or contact input to electromagnetic valve output (or dry contact output) to alarm output

**Test switch:** LED provided

### INPUT

■ **CONTACT INPUT:** dry contact or open collector  
**Contact detecting:** 24V DC, approx. 25mA

■ **DCS STATUS OUTPUT:** dry contact or open collector  
**Contact detecting:** 24V DC, approx. 25mA

### OUTPUT

■ **ELECTROMAGNETIC VALVE:** voltage contact  
**Rated load:** 120V AC @0.5A (cosφ=1)  
 24V DC @0.5A (resistive load)

**Load current:** 8A max. for the total of 16 channels

■ **DRY CONTACT:** dry contact (electromagnetic valve or dry contact selectable with the jumper on the PCB)

**Rated load:** 120V AC @3A (cosφ=1)  
 24V DC @3A (resistive load)

**Relay protection:** For maximum relay life with inductive loads (e.g. coil), external protection including noise quenching is recommended.

■ **DCS STATUS INPUT:** relay contact

**Rated load:** 30V DC @3A (resistive load)

### INSTALLATION

**Power input:** 24V DC ±10%, approx. 65mA (ripple 10% p-p max.)

**Operating temperature:** -5 to +55°C (23 to 131°F)

**Operating humidity:** 30 to 90% RH (non-condensing)

**Mounting:** Standard Rack 38N-B□

**Dimensions:** W23×H149×D102 mm (0.91"×5.87"×4.02")

**Weight:** 150 g (0.33 lbs)

### PERFORMANCE

**Insulation resistance:** ≥100MΩ with 500V DC

**Dielectric strength:** 1000V AC @1 minute

**Relay life:** mechanical life  $5 \times 10^7$  cycles  
 electrical life  $10^5$  cycles  
 (30 cycles/min. at rated load)

### FRONT VIEW mm (inch)

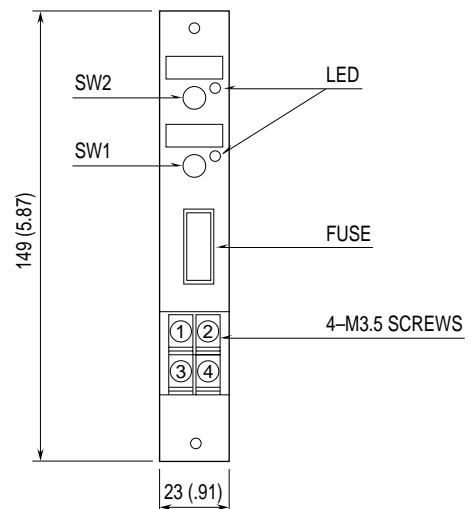

**OPERATIONS**

INPUT				OUTPUT					
SW2 STATUS	SW1 STATUS	DCS OUTPUT	INPUT	LED (IN)	DCS INPUT		LED (OUT)	OUTPUT	
					CONTACT A*	CONTACT B*			
DCS	DCS	ON	ON	ON	ON	ON	ON	ON	
			OFF	OFF	OFF	OFF	ON	ON	
		OFF	ON	ON	ON	ON	ON	OFF	OFF
			OFF	OFF	OFF	OFF	OFF	OFF	OFF
	ON	ON	ON / OFF	ON	ON	ON	ON	ON	
		OFF	ON / OFF	ON	ON	ON	OFF	OFF	
TEST	ON	ON / OFF	ON	ON	ON	OFF	OFF		
	OFF	ON / OFF	OFF	OFF	OFF	ON	OFF		
OFF	N/A						OFF	OFF	
ON	N/A						ON	ON	

\*Selectable with a jumper.

**SCHEMATIC CIRCUITRY & CONNECTION DIAGRAM**

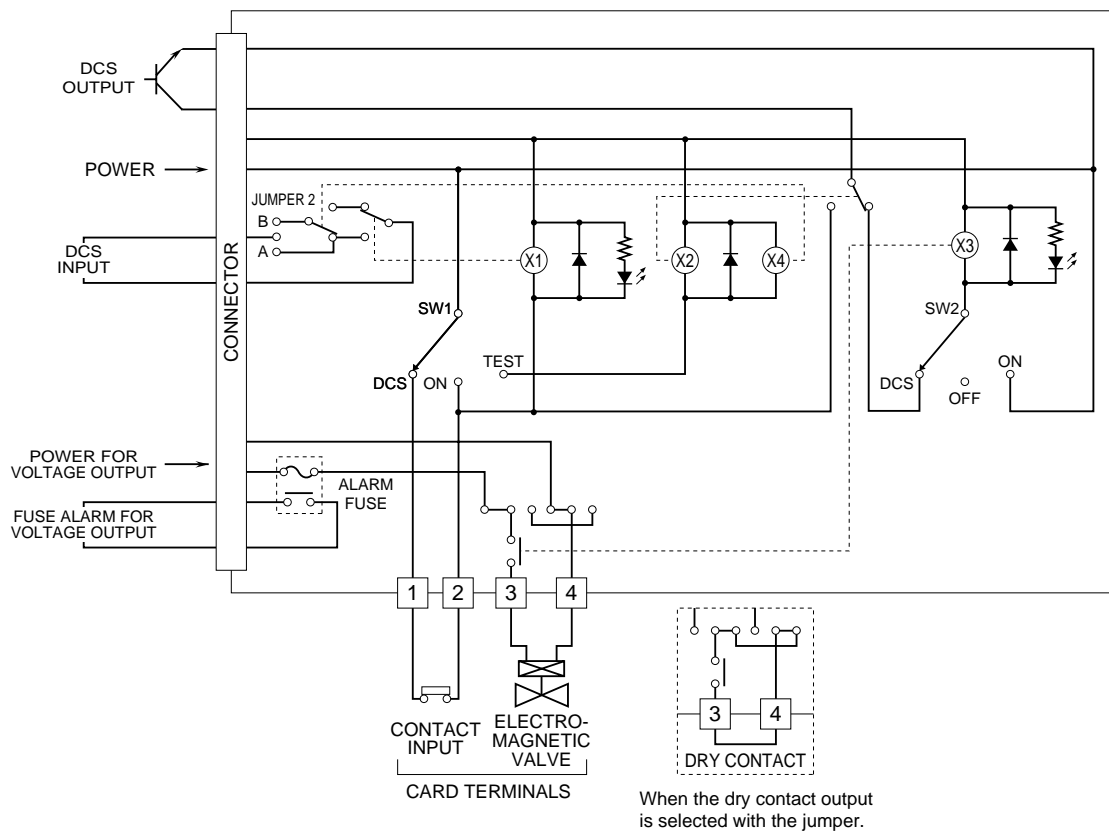

## <MOTOR DRIVE I/O RELAY CARD >

***DISCONTINUED MODEL***  
*Replaced with Model 38N2-3*

### MODEL & SUFFIX CODE SELECTION

**38N-3**

**MODEL** \_\_\_\_\_  
**INPUT** \_\_\_\_\_  
 Dry contact or open collector  
**OUTPUT** \_\_\_\_\_  
 Relay contact  
**FUNCTION** \_\_\_\_\_  
**3** : Motor drive use

### ORDERING INFORMATION

Specify code number. (e.g. 38N-3)

### GENERAL SPECIFICATIONS

**Construction:** rack mounted; terminal access via screw terminals at the front and via connector at the rear

#### Connection

**Input:** M3.5 screw terminals  
**DCS I/O:** card-edge connector  
**Output:** M3.5 screw terminals  
**Power input:** supplied from card-edge connector  
**Screw terminal material:** nickel-plated steel (torque 0.8 N·m)

**Isolation:** DCS output or power or feedback input to motor drive to DCS input

**Indicator LED:** orange light turns on when the motor is started up.  
 red light turns on when the feedback input is turned on.

### INPUT

■ **FEEDBACK INPUT:** dry contact or open collector  
**Contact detecting:** 24V DC, approx. 25mA

■ **DCS STATUS OUTPUT:** dry contact or open collector  
**Contact detecting:** 24V DC, approx. 50mA

### OUTPUT

■ **MOTOR DRIVE OUTPUT:** relay contact  
**Rated load:** 250V AC @3A (cosφ=1)  
 30V DC @3A (resistive load)  
**Relay protection:** For maximum relay life with inductive loads (e.g. coil), external protection including noise quenching is recommended.

■ **DCS STATUS INPUT:** relay contact  
**Rated load:** 30V DC @3A (resistive load)

### INSTALLATION

**Power input:** 24V DC ±10%, approx. 80mA  
 (ripple 10% p-p max.)

**Operating temperature:** -5 to +55°C (23 to 131°F)

**Operating humidity:** 30 to 90% RH (non-condensing)

**Mounting:** Standard Rack 38N-B□

**Dimensions:** W23×H149×D102 mm  
 (0.91"×5.87"×4.02")

**Weight:** 150 g (0.33 lbs)

### PERFORMANCE

**Insulation resistance:** ≥100MΩ with 500V DC

**Dielectric strength:** 1000V AC @1 minute

**Relay life:** mechanical life  $5 \times 10^7$  cycles  
 electrical life  $10^5$  cycles  
 (30 cycles/min. at rated load)

### FRONT VIEW mm (inch)

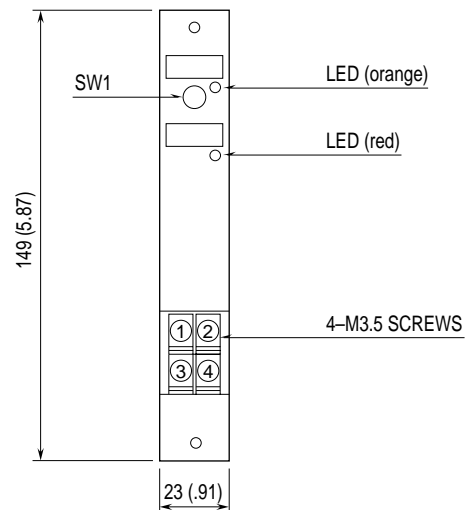

## OPERATIONS

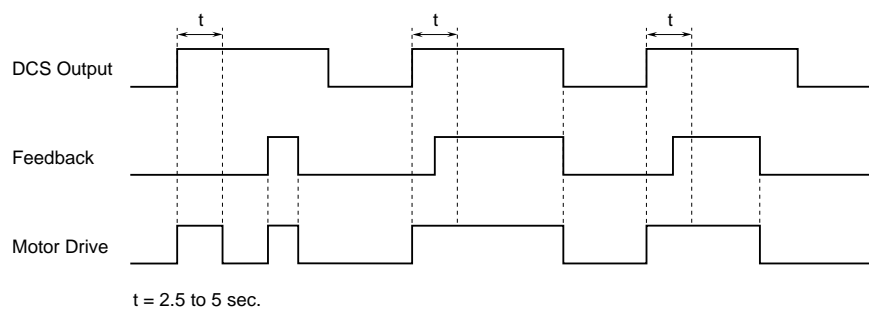

## SCHEMATIC CIRCUITRY & CONNECTION DIAGRAM

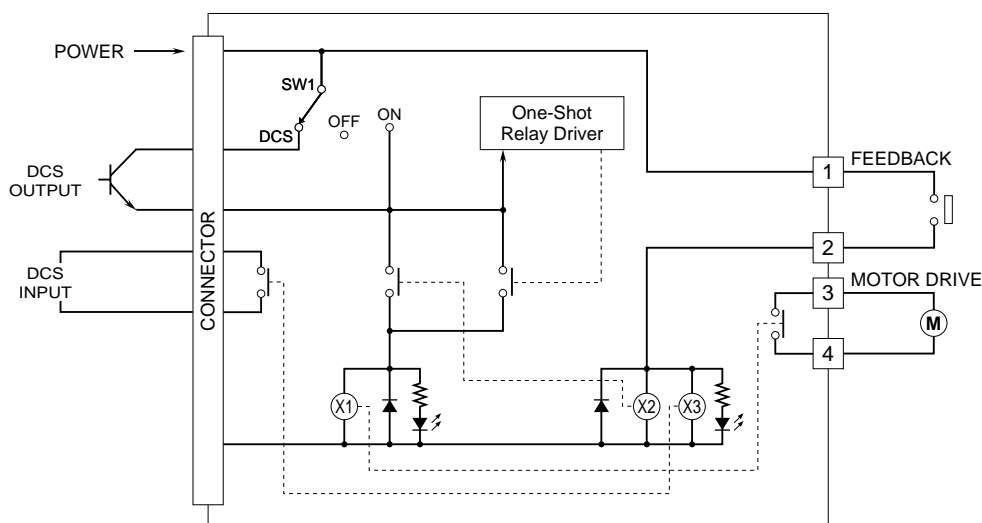



## <MOTOR DRIVE I/O RELAY CARD >

### MODEL & SUFFIX CODE SELECTION

**38N2-3**

**MODEL** \_\_\_\_\_

**INPUT**  
Dry contact or open collector

**OUTPUT**  
Relay contact

**FUNCTION** \_\_\_\_\_

**3** : Motor drive use

### ORDERING INFORMATION

Specify code number. (e.g. 38N2-3)

### GENERAL SPECIFICATIONS

**Construction:** rack mounted; terminal access via screw terminals at the front and via connector at the rear

#### Connection

**Input:** M3.5 screw terminals  
**DCS I/O:** card-edge connector  
**Output:** M3.5 screw terminals  
**Power input:** supplied from card-edge connector  
**Screw terminal material:** nickel-plated steel (torque 0.8 N·m)  
**Isolation:** DCS output or power or feedback input to motor drive to DCS input  
**Indicator LED:** orange light turns on when the motor is started up.  
 red light turns on when the feedback input is turned on.

### INPUT

■ **FEEDBACK INPUT:** dry contact or open collector  
**Contact detecting:** 24V DC, approx. 35mA

■ **DCS STATUS OUTPUT:** dry contact or open collector  
**Contact detecting:** 24V DC, approx. 60mA

### OUTPUT

■ **MOTOR DRIVE OUTPUT:** relay contact  
**Rated load:** 250V AC @3A (cosφ=1)  
 30V DC @3A (resistive load)  
**Relay protection:** For maximum relay life with inductive loads (e.g. coil), external protection including noise quenching is recommended.

■ **DCS STATUS INPUT:** relay contact  
**Rated load:** 30V DC @3A (resistive load)

### INSTALLATION

**Power input:** 24V DC ±10%, approx. 95mA (ripple 10% p-p max.)  
**Operating temperature:** -5 to +55°C (23 to 131°F)  
**Operating humidity:** 30 to 90% RH (non-condensing)  
**Mounting:** Standard Rack 38N-B□  
**Dimensions:** W23×H149×D102 mm (0.91"×5.87"×4.02")  
**Weight:** 150 g (0.33 lbs)

### PERFORMANCE

**Insulation resistance:** ≥100MΩ with 500V DC  
**Dielectric strength:** 1000V AC @1 minute  
**Relay life:** mechanical life 5 × 10<sup>7</sup> cycles  
 electrical life 10<sup>5</sup> cycles (30 cycles/min. at rated load)

### FRONT VIEW mm (inch)

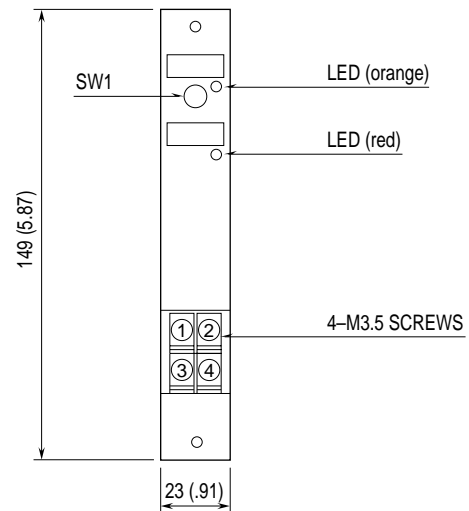

## OPERATIONS

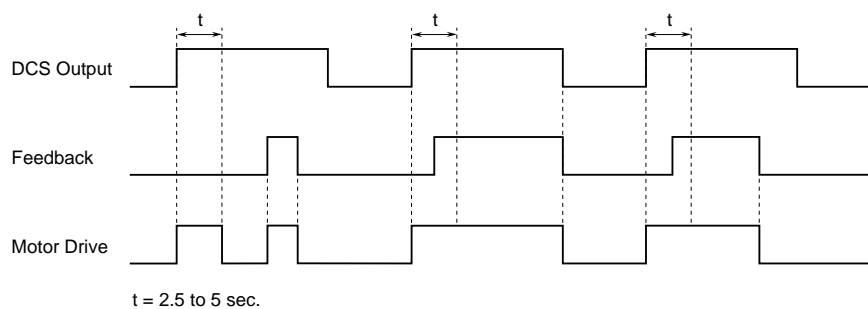

## SCHEMATIC CIRCUITRY & CONNECTION DIAGRAM

