

Customer Information Sheet

DRAWING No.: G125-MHXXX05L3X

IF IN DOUBT - ASK

©

NOT TO SCALE

THIRD ANGLE PROJECTION

ALL DIMENSIONS IN mm

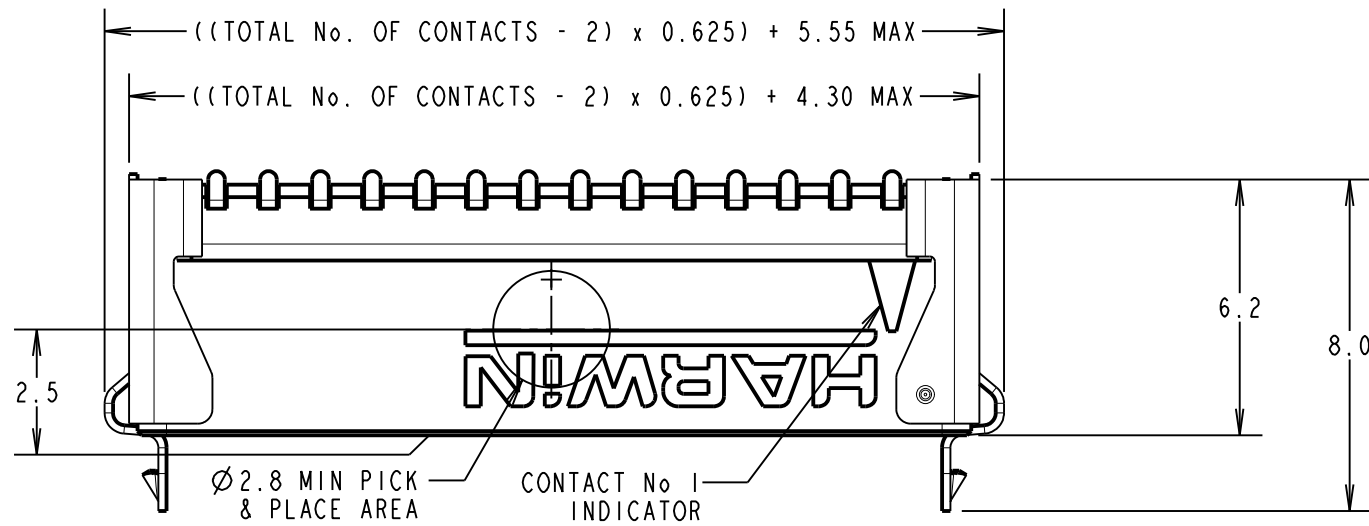
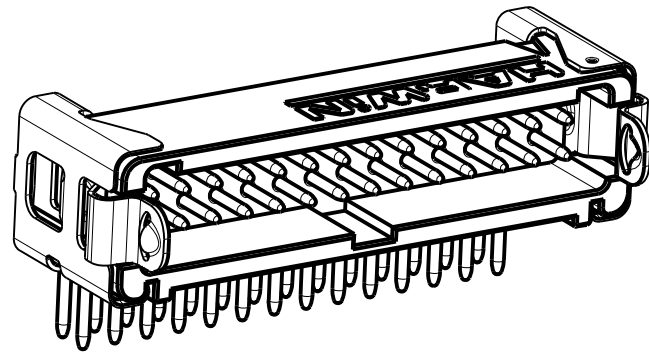

ORDER CODE: **G125-MHXXX05L3X**

CONTACT STYLE: _____
 3.3mm PC-TAIL = H1
 4.8mm PC-TAIL = H2

TOTAL No. OF CONTACTS: _____
 06, 10, 12, 16, 20, 26, 34, 50

PACK TYPE: _____
 R = 250 PCS IN TAPE AND REEL
 P = EACH (CUT TAPE LENGTHS)

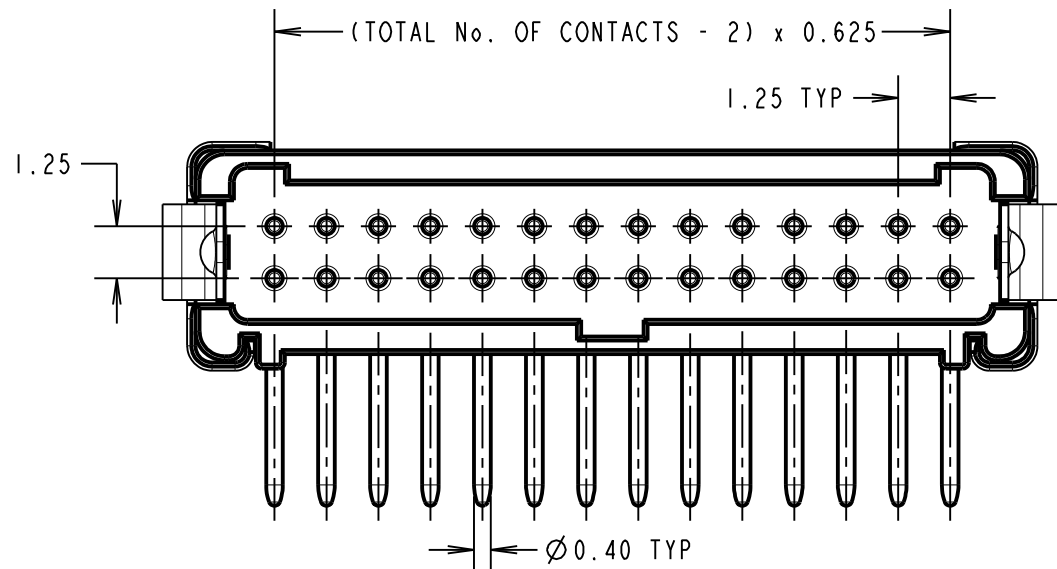
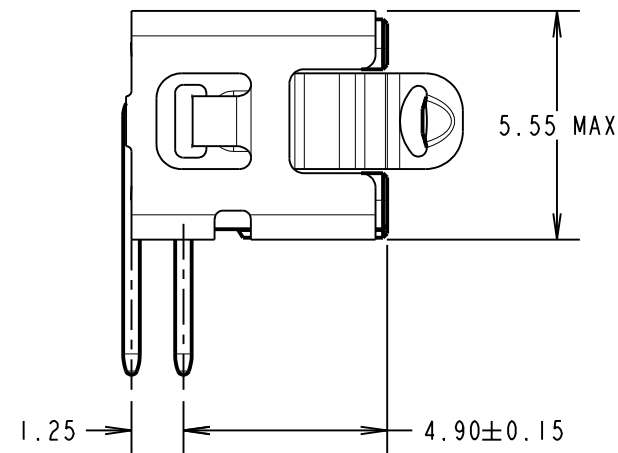

CONTACT STYLE	DIM 'B'
H1	3.3±0.15
H2	4.8±0.15

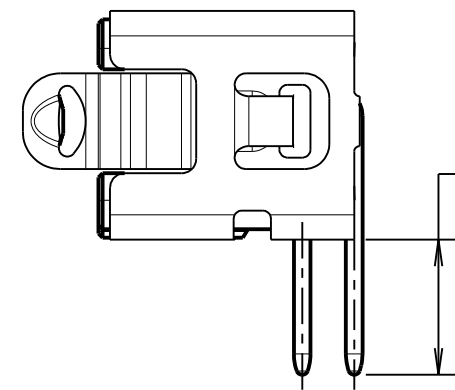

DIM 'B'
SEE TABLE

FULL LOGO ONLY
ON 20 TO 50 WAY.
'H' ON 6 & 10 WAY.
'HWN' ON 12 & 16 WAY.

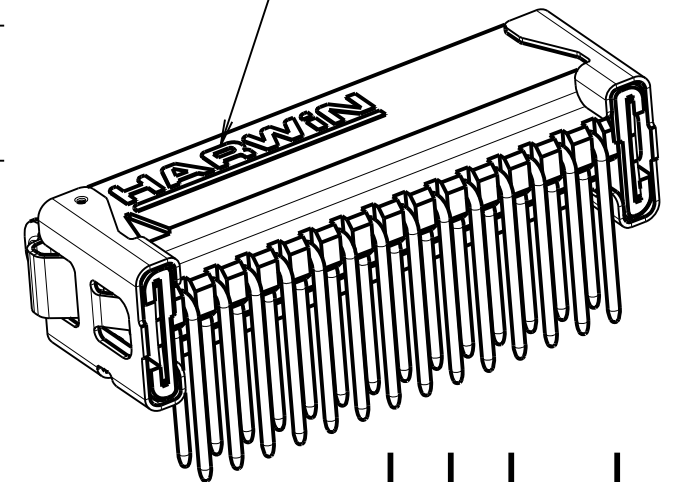

RECOMMENDED PCB LAYOUT

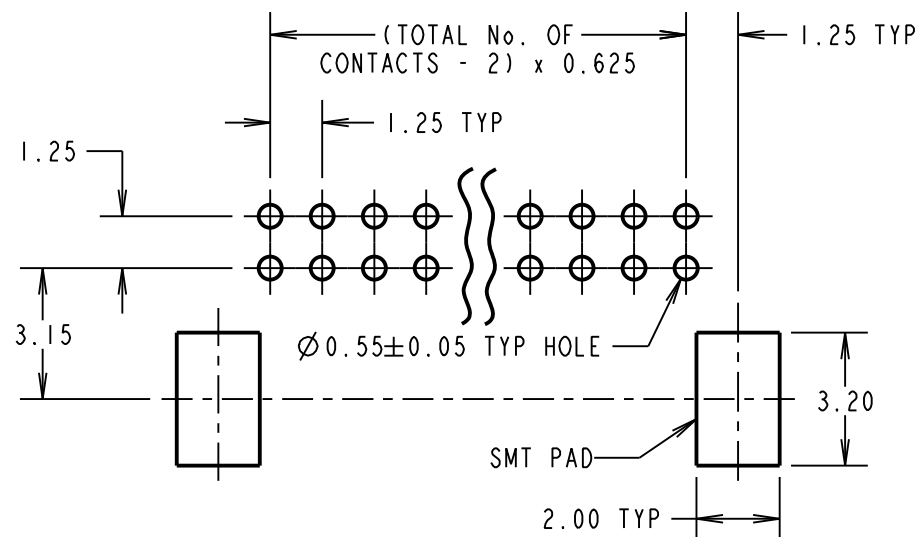

CONNECTOR DETAILS AND PCB LAYOUT ONLY
SEE SHEET 3 FOR TAPE AND REEL DETAILS

NOTES:

- FOR COMPLETE SPECIFICATION, SEE COMPONENT SPECIFICATION C125XX (LATEST ISSUE). SEE G125-SERIES CONNECTORS' SPECIFICATION SHEET FOR MATERIALS, FINISH AND SPECIFICATION SUMMARY.
- SEE SHEET 3 FOR TAPE & REEL DETAILS OF THIS PRODUCT.

MGP	1	17.02.17	20385
NAME	ISS.	DATE	C/NOTE
APPROVED: MGP			
CHECKED: MSP			
DRAWN: MARK G PLESTED			
CUSTOMER REF.:			
ASSEMBLY DRG:			

HARWIN

www.harwin.com
technical@harwin.com

THIS DRAWING AND ANY INFORMATION OR DESCRIPTIVE MATTER SET OUT HEREON ARE CONFIDENTIAL AND COPYRIGHT PROPERTY OF THE HARWIN GROUP AND MUST NOT BE DISCLOSED, LOANED, COPIED OR USED FOR MANUFACTURING, TENDERING OR FOR ANY OTHER PURPOSE WITHOUT THEIR WRITTEN PERMISSION.

TOLERANCES

X. = ±1mm
 X.X = ±0.50mm
 X.XX = ±0.10mm
 X.XXX = ±0.01mm
 ANGLES = ±5°
 UNLESS STATED

MATERIAL:

SEE NOTE 1

FINISH: SEE NOTE 1

S/AREA:

mm²

TITLE:

G125 MALE HORIZONTAL PC TAIL
SERIES IN TAPE & REEL

DRAWING NUMBER:

G125-MHXXX05L3X

SHT

2 OF 3

Customer Information Sheet

DRAWING No.: G125-MHXXX05L3X

IF IN DOUBT - ASK

©

NOT TO SCALE

THIRD ANGLE PROJECTION

ALL DIMENSIONS IN mm

ORDER CODE: **G125-MHXXX05L3X**

CONTACT STYLE:
3.3mm PC-TAIL = H1
4.8mm PC-TAIL = H2

TOTAL No. OF CONTACTS:
06, 10, 12, 16, 20, 26, 34, 50

PACK TYPE:
R = 250 PCS IN TAPE AND REEL
P = EACH (CUT TAPE LENGTHS)

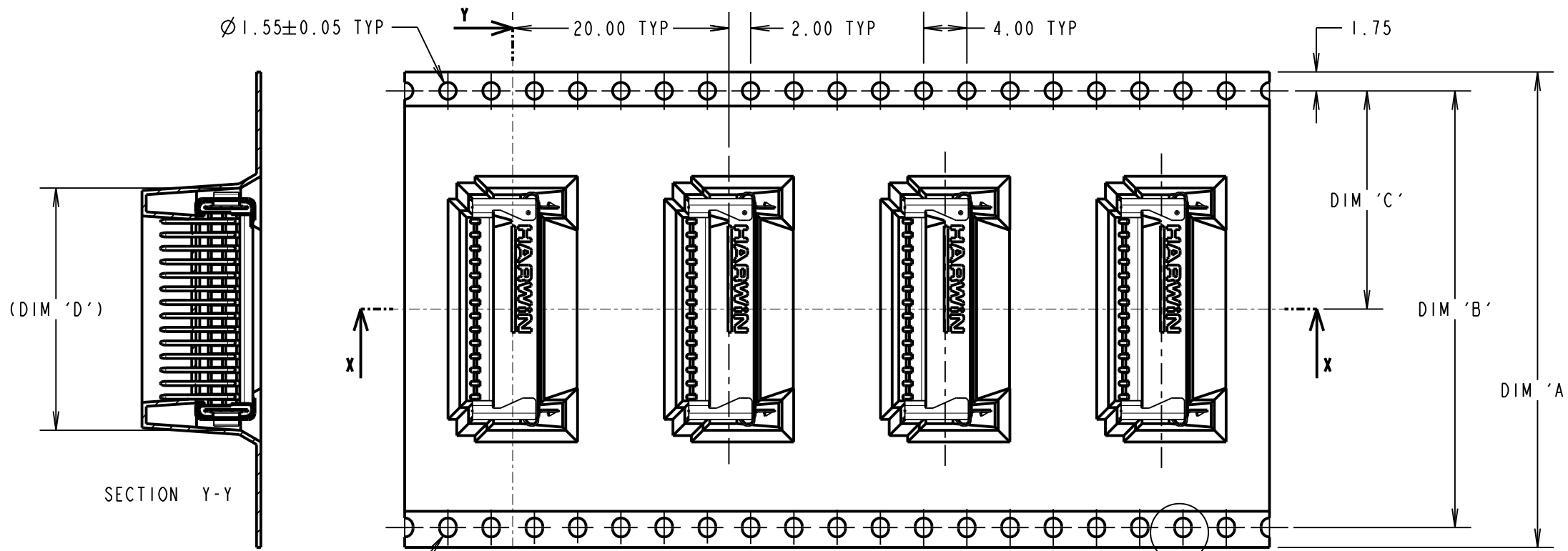

(DIM 'D')

SECTION Y-Y

SEE NOTE 5

DETAIL A

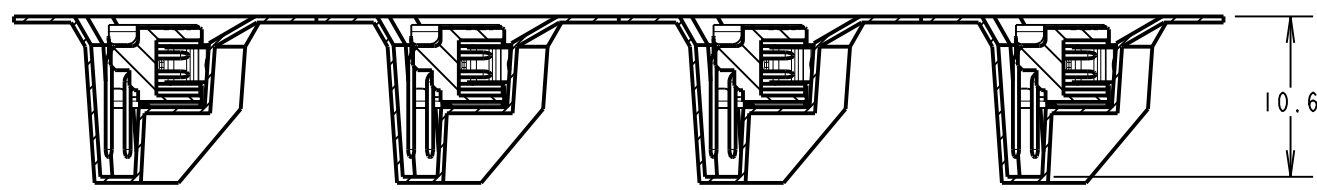
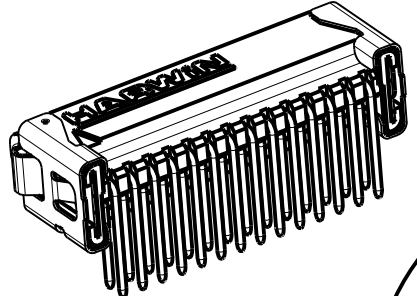
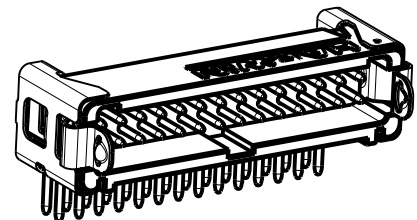

SECTION X-X

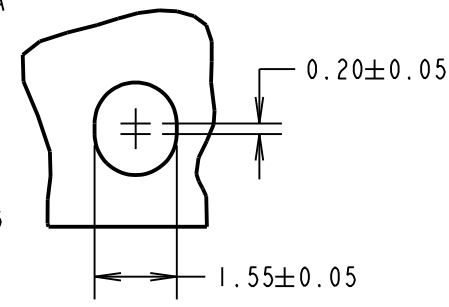

DETAIL A
SEE NOTE 5

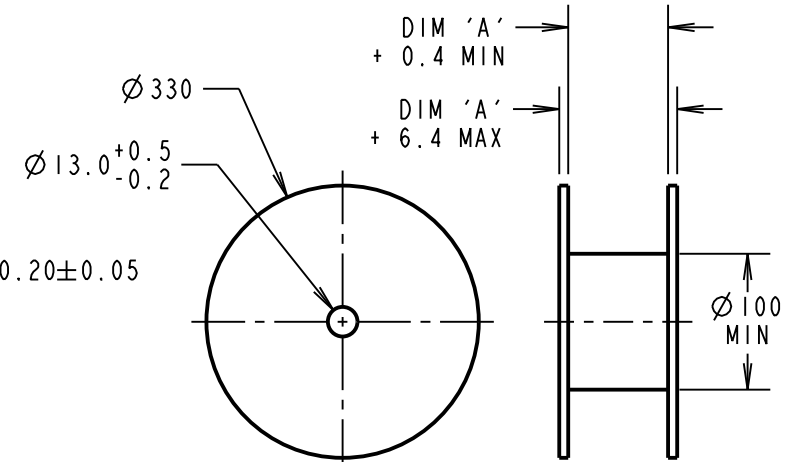

REEL DETAILS

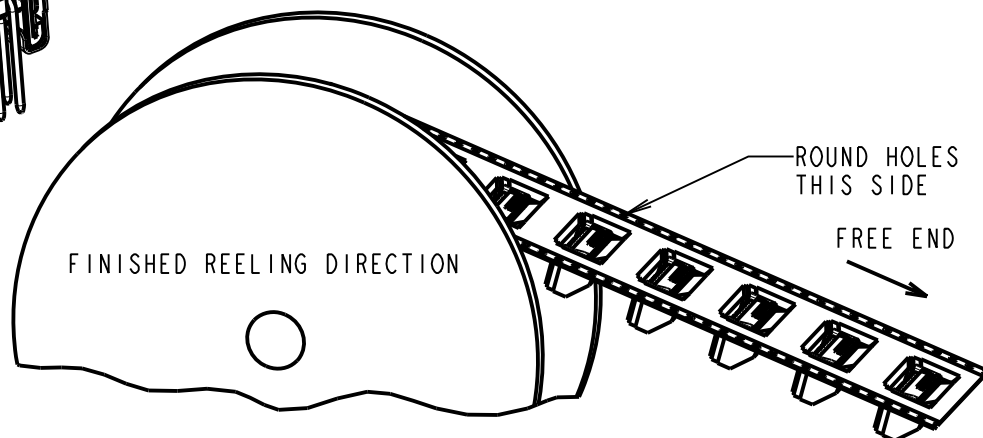

FINISHED REELING DIRECTION

ROUND HOLES
THIS SIDE

FREE END

REELED PART No.	LOOSE PART No.	DIM 'A'	DIM 'B'	DIM 'C'	DIM 'D'
G125-MHX0605L3R	G125-MHX0605L3P	24.0 +0.3/-0.1	NO ELONGATED HOLE	11.50	8.5 11.0
G125-MHX1005L3R	G125-MHX1005L3P	32.0±0.3	28.40	14.20	12.2
G125-MHX1205L3R	G125-MHX1205L3P				14.7
G125-MHX1605L3R	G125-MHX1605L3P	44.0±0.3	40.40	20.2±0.15	17.2
G125-MHX2005L3R	G125-MHX2005L3P				21.0
G125-MHX2605L3R	G125-MHX2605L3P				26.0
G125-MHX3405L3R	G125-MHX3405L3P	56.0±0.3	52.40	26.2±0.15	36.0
G125-MHX5005L3R	G125-MHX5005L3P				

MGP	1	17.02.17	20385
NAME	ISS.	DATE	C/NOTE
APPROVED: MGP			
CHECKED: MSP			
DRAWN: MARK G PLESTED			
CUSTOMER REF.:			
ASSEMBLY DRG:			

NOTES:

- FOR "R" VARIANT, QUANTITY OF COMPONENTS PER REEL = 250.
- FOR "P" VARIANT, QUANTITY IS CUT FROM G125-MHXXX05L3R.
- THIS PRODUCT IS TAPED AND REELED IN GENERAL ACCORDANCE WITH EIA-481-2-A (ELECTRONIC INDUSTRIES ASSOCIATION).
- FOR COMPLETE SPECIFICATION, SEE COMPONENT SPECIFICATION C125XX (LATEST ISSUE).
- ELONGATED SPROCKET HOLE NOT PRESENT ON 06 & 10 POSITIONS.
- SEE SHEET 2 FOR CONNECTOR DETAILS.

HARWIN

www.harwin.com
technical@harwin.com

THIS DRAWING AND ANY INFORMATION OR DESCRIPTIVE MATTER SET OUT HEREON ARE CONFIDENTIAL AND COPYRIGHT PROPERTY OF THE HARWIN GROUP AND MUST NOT BE DISCLOSED, LOANED, COPIED OR USED FOR MANUFACTURING, TENDERING OR FOR ANY OTHER PURPOSE WITHOUT THEIR WRITTEN PERMISSION.

TOLERANCES

X. = ±1mm
X.X = ±0.50mm
X.XX = ±0.10mm
X.XXX = ±0.01mm
ANGLES = ±5°
UNLESS STATED

MATERIAL:

SEE SHEET 2

FINISH:

SEE SHEET 2

S/AREA:

mm²

TITLE:

G125 MALE HORIZONTAL PC TAIL SERIES IN TAPE & REEL

DRAWING NUMBER:

G125-MHXXX05L3X

SHT

3 OF 3

Customer Information Sheet

DRAWING No.: G125-SERIES COMPONENT SPECIFICATION

IF IN DOUBT - ASK

(C)

NOT TO SCALE

THIRD ANGLE PROJECTION

ALL DIMENSIONS IN mm

SPECIFICATIONS:

MATERIALS:

MOULDING, PICK & PLACE CAP:
POLYAMIDE, PA4T-GF30 FR(40) UL94V-0,
HALOGEN FREE, FREE OF RED PHOSPHORUS

CONTACTS:

MALE PC-TAIL/SMT = PHOSPHOR BRONZE
MALE CRIMP = BRASS
ALL FEMALE CONTACTS = COPPER ALLOY

LOCKING HARDWARE:

LATCHES: COPPER NICKEL TIN ALLOY
SCREW LOCK: STAINLESS STEEL

BACK POTTING COMPOUND (CABLE ASSEMBLIES ONLY):
STYCAST 2651 MM BACK POTTING WITH CATALYST 9

FINISH:

ALL CONTACTS:
0.2-0.3µ GOLD OVER NICKEL
LATCHES:
3.0µ 100% TIN OVER NICKEL

MECHANICAL:

DURABILITY = 1000 OPERATIONS
INSERTION FORCE = 2.8N MAX
WITHDRAWAL FORCE = 0.2N MIN

ENVIRONMENTAL:

CLASSIFICATION: 65/150/56 DAYS AT 93% RH

TEMPERATURE RANGE:

EIA-364-32 : 2000 TEST CONDITION IV, DWELL
30mins, 5 CYCLES -65°C TO +150°C

* EIA-364-28D : 1999: TEST CONDITION IV: VIBRATION SEVERITY:
10Hz TO 2000Hz, 1.5MM, 198 mm/s² (20G). DURATION 2Hr

* EIA-364-27B : 1996: TEST CONDITION E SHOCK SEVERITY: 981 mm/s²
(100G) FOR 6ms IN Z AXIS, 490 mm/s² (50G) FOR 11ms IN X & Y AXIS.

* EIA-364-01A : 2000: ACCELERATION: 490 mm/s² (50G)
* BUMP SEVERITY: 390 mm/s² (40G), 4000± 10 BUMPS
* TESTED WITH LATCHED CONNECTORS

ELECTRICAL:

CURRENT RATING:

EIA-364-70A : 1998: INDIVIDUAL CONTACT IN ISOLATION AT 25°C = 2.8A MAX
EIA-364-70A : 1998: ALL CONTACTS SIMULTANEOUSLY AT 25°C = 2.0A MAX

CONTACT RESISTANCE:

EIA-364-06C : 2006: INITIAL CONTACT RESISTANCE = 20mΩ MAX
EIA-364-06C : 2006: CONTACT RESISTANCE AFTER CONDITIONING = 25mΩ MAX

WORKING VOLTAGE:

EIA-364-20C : 2004: SEA LEVEL (1006mbar) = 450V DC/AC PEAK
EIA-364-20C : 2004: ALTITUDE LEVEL (44mbar) = 250V DC/AC PEAK

VOLTAGE PROOF AT SEA LEVEL (1013mbar) = 600V DC/AC PEAK

INSULATION RESISTANCE:

EIA-364-21C : 2000: INSULATION RESISTANCE (INITIAL)
= 10 GΩ MIN AT 500V DC
EIA-364-21C : 2000: INSULATION RESISTANCE (AFTER CONDITIONING)
= >1 GΩ MIN AT 500V DC

FOR FULL COMPONENT SPECIFICATION SEE C125XX (LATEST ISSUE).

PATENT PENDING
UK 1205109.0



MGP	4	22.06.17	20668
NAME	ISS.	DATE	C/NOTE
APPROVED: MGP			
CHECKED: SB			
DRAWN:		S.FLOWER	
CUSTOMER REF.:			
ASSEMBLY DRG:			

HARWIN

www.harwin.com
technical@harwin.com

THIS DRAWING AND ANY INFORMATION OR DESCRIPTIVE MATTER SET OUT HEREON ARE CONFIDENTIAL AND COPYRIGHT PROPERTY OF THE HARWIN GROUP AND MUST NOT BE DISCLOSED, LOANED, COPIED OR USED FOR MANUFACTURING, TENDERING OR FOR ANY OTHER PURPOSE WITHOUT THEIR WRITTEN PERMISSION.

TOLERANCES
X = ±1mm
X.X = ±0.50mm
X.XX = ±0.10mm
X.XXX = ±0.01mm
ANGLES = ±5°
UNLESS STATED

MATERIAL:

SEE ABOVE

FINISH:

SEE ABOVE

S/AREA:

mm²

TITLE:

G125 SERIES COMPONENT SPECIFICATION

DRAWING NUMBER:

G125-SERIES CONNECTORS

SHT
1 OF 1