

Bargraph Indicators 48 Series

BARGRAPH INDICATING ALARM
(with 4-digit digital meter)

MODEL **48DV**

MODEL & SUFFIX CODE SELECTION

MODEL _____ 48DV-□□V□□

ALARM OUTPUT _____

0 : None
2 : 2 points
4 : 4 points

LED COLOR _____

R : Red
Y : Amber
G : Green
C : Multi-color (red, amber and green)

INSTALLATION _____

V : Vertical

INPUT _____

Current	Voltage
A : 4 – 20mA DC	3 : 0 – 1V DC
B : 2 – 10mA DC	4 : 0 – 10V DC
C : 1 – 5mA DC	5 : 0 – 5V DC
D : 0 – 20mA DC	6 : 1 – 5V DC
E : 0 – 16mA DC	0 : Specify voltage*
F : 0 – 10mA DC	
G : 0 – 1mA DC	
H : 10 – 50mA DC	
Z : Specify current*	

*0% input must be 0mA or 0V.

POWER INPUT _____

K : 85 – 132V AC
L : 170 – 264V AC
R : 24V DC

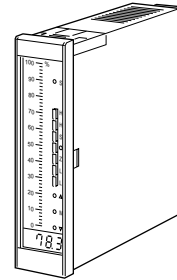

Functions & Features

- Displaying a process variable in graphic bargraph of 101 LED segments
- Clear 4-digit digital meter
- Providing max. 4 alarm contact outputs
- Relays can be used with 110V DC power
- Multi-color indicator
- High-density mounting

Bargraph: 101-segment LED

Scale

- Length:** 100 mm (3.96"), 1.5 mm (.06") wide
- Characters:** max. 4 characters incl. decimal point
- Divisions:** 22 – 54.9
- Engineering unit:** max. 5 characters
- Digital display:** 8 mm (.31"), red LED
- Number of digits:** 4 digits
- Scaled range:** -1999 to 0 to 9999
(Min. 3 significant digits)

Minimum scaling span: 3 digits (100) regardless of the decimal point position

Read rate: 14/s

Moving average sample number: 4 (factory setting; field-selectable among 1, 2, 4, 8 or 16)

H & L alarm output delay: 0 sec. (factory setting; field-selectable between 0 and 15 sec. by 1 sec. increments)

Setpoint adjustment

48DV-2: H [L setpoint + 1%] to 100%
L 0 to [H setpoint – 1%]

48DV-4: HH [H setpoint + 1%] to 100%
H [L setpoint + 1%] to [HH setpoint – 1%]
L [LL setpoint + 1%] to [H setpoint – 1%]
LL 0 to [L setpoint – 1%]

Alarm hysteresis: 1%

Zero & span adjustments: ±10% (front)

Isolation: input to alarm output to power

ORDERING INFORMATION

Specify code number and variables.

- **Code number** (e.g. 48DV-4RVA-R)
- **Special input range** (For codes Z & 0)
- **Scale** (e.g. 0 – 100%)
- **Color pattern for multi-color indicator** (e.g. pattern 2)

GENERAL SPECIFICATIONS

Construction: panel flush mounting

Connection: M3 screw terminals
(chromated brass; torque 0.6 N·m)

Material

Housing: ABS resin

Scale plate: aluminium (white scale & characters on black base)

INPUT & OUTPUT

INPUT

• **DC Current:** 0 – 50mA DC; input resistor incorporated (2W)

Minimum span: 1mA

Input resistance

Input	Input Resistance
4 – 20mA	: 10 (Ω)
2 – 10mA	: 20
1 – 5mA	: 39
0 – 20mA	: 10
0 – 16mA	: 12
0 – 10mA	: 20
0 – 1mA	: 200
10 – 50mA	: 5.1

• **DC Voltage:** 0 – 10V DC

Minimum span: 1V

Input resistance: 1M Ω

ALARM OUTPUT

Alarm Trip Operation Terminal No. in parentheses

• **Output Code : 2**

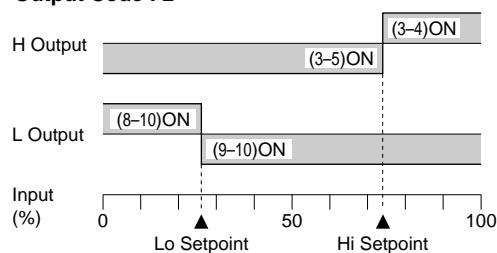

• **Output Code : 4**

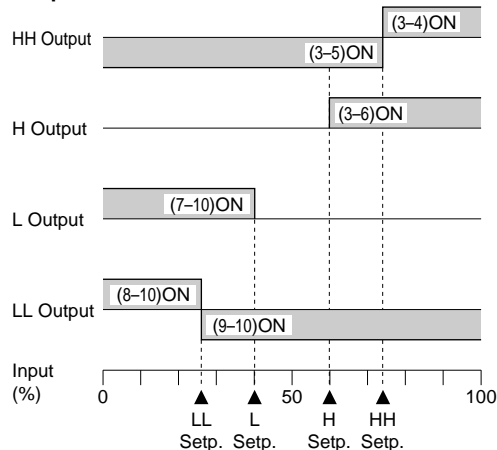

Trip Operation in Power Failure

: terminals 3 – 5, 9 – 10 turn ON

• **Relay Contact:** 125V AC @0.5A ($\cos\phi=1$)
30V DC @2A (resistive load)
electrical life $\geq 5 \times 10^5$ cycles (rate 30/min.)

Maximum switching voltage: 250V AC or 220V DC

Maximum switching power: 125VA or 60W

Minimum load: 10mV DC @10 μ A

Mechanical life: $\geq 10^8$ cycles

INSTALLATION

Power input

AC: operational voltage range 85 – 132V or
170 – 264V, 47 – 63 Hz, approx. 7VA

DC: operational voltage range 24V $\pm 15\%$,
approx. 6W (ripple 10% p-p max.)

Operating temperature: 0 to 45°C (32 to 113°F)

Operating humidity: 40 to 80% RH (non-condensing)

Mounting: panel flush mounting

Dimensions: W41 \times H144 \times D164 mm (1.61" \times 5.67" \times 6.46")

Weight: 420 g (0.93 lbs)

PERFORMANCE in percentage of span

Accuracy

Bargraph: $\pm 1\%$ ± 1 digit

Digital meter: $\pm 0.5\%$ ± 1 digit

Setpoint accuracy

Bargraph: $\pm 1\%$

Digital meter: $\pm 0.5\%$

Response time: 0.5 seconds

Insulation resistance: $\geq 10M\Omega$ with 500V DC

(input to output to power)

Dielectric strength: 1500V AC @1 minute

(input to power or ground)

1000V AC @1 minute (power to ground,
output to input or power or ground)

CONNECTION DIAGRAM

■48DV-0

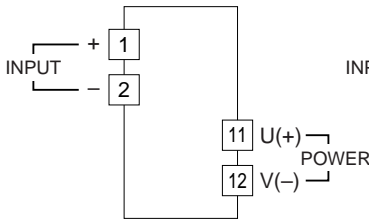

■Relay Protection •AC Powered

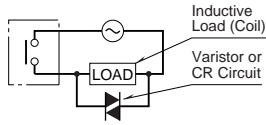

■48DV-2

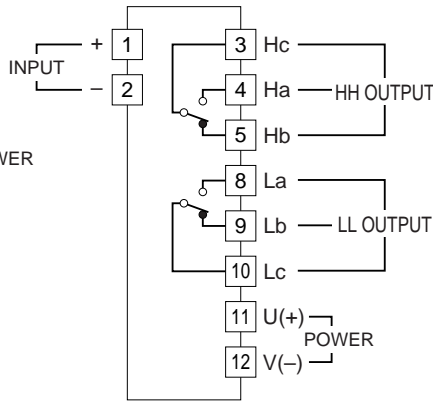

•DC Powered

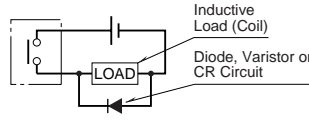

■48DV-4

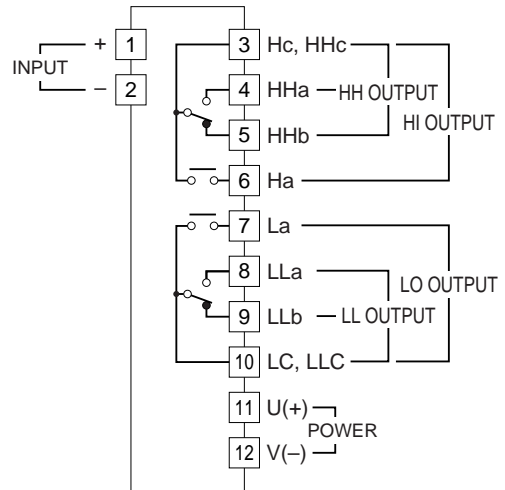

STANDARD SCALE & UNIT EXAMPLES

■DIVISIONS

Number of divisions depends upon the scale range.

■STANDARD SCALES & DIVISIONS (example)

	Pattern 1		Pattern 2		Pattern 3		Pattern 4		Pattern 5	
Span of Scale Range	1.1 ≤ SPAN < 1.3		1.3 ≤ SPAN < 2.0		2.0 ≤ SPAN < 2.6		2.6 ≤ SPAN < 5.5		5.5 ≤ SPAN < 11.0	
Standard Divisions	22 through 25.9		26 through 39.9		40 through 51.9		26 through 54.9		27.5 through 54.9	
Ratio	20		20		20		10		5	
Standard Scales	 22 div.	 25.9 div.	 26 div.	 39.9 div.	 40 div.	 51.9 div.	 26 div.	 54.9 div.	 27.5 div.	 54.9 div.

Engineering unit: %, °C, Nm³/h, m³/h, t/h, km³/h, kg/h, l/h, Pa, kPa, abs, ppm, pH, psi, kg/cm²G, N/m², N/cm², lb/h, J, kJ, NI, m³, lbs, Ω, μΩ, 1°

Span of Scale Range = (Full Scale – Zero Scale) × 10ⁿ

where n = integer (Determine 'n' so that the span of scale range is 1.1 or greater than 1.1, and smaller than 11.0.)

[Example 1] Scale range 0 to 100

Span of Scale Range = (100 – 0) × 10⁻¹ = 10

Span of 10 falls into Pattern 5 according to the above table. Number of divisions is calculated from the Span of Scale Range multiplied by the ratio (10 × 5). The scale range 0 to 100 is provided with 50 divisions.

[Example 2] Scale range -10 to +10

Span of Scale Range = (10 – (-10)) × 10⁻¹ = 2

Span of 2 falls into Pattern 3 according to the above table. Number of divisions is calculated from the Span of Scale Range multiplied by the ratio (2 × 20). The scale range -10 to +10 is provided with 40 divisions.

Example 1

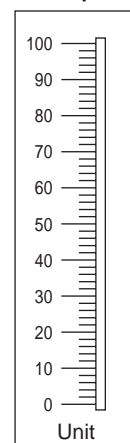

Example 2

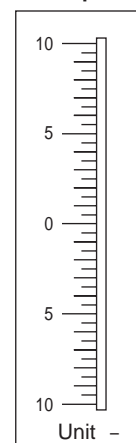

FRONT PANEL CONFIGURATION

■48DV-2, 48DV-4

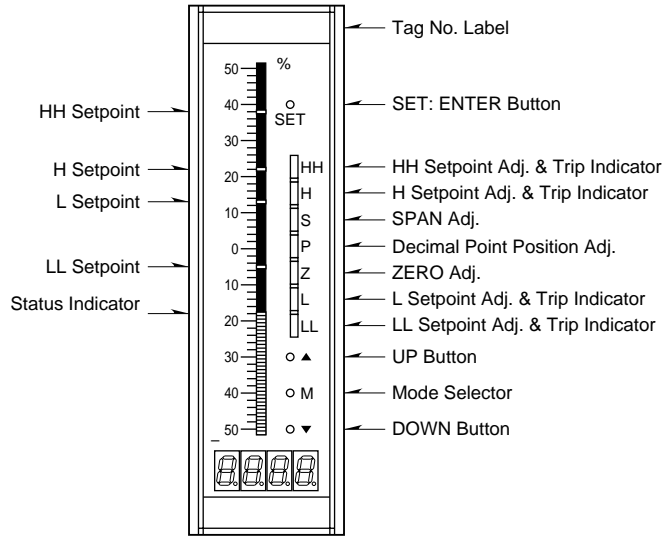

HH and LL Setpoint Adj. are deleted with model 48DV-2.

•Multi-Color Indication

Pattern 1

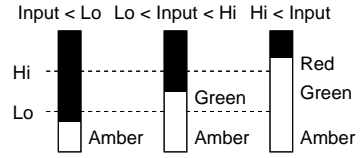

Pattern 2

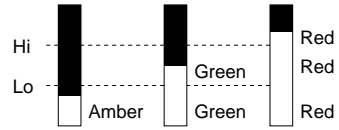

■48DV-0

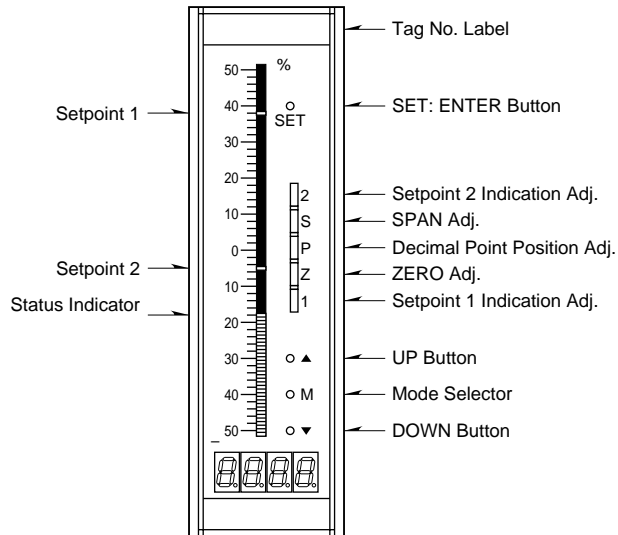

Setpoint 1 and 2 Adj. are deleted with models 48DV-0R, 0Y, or 0G.

•Multi-Color Indication

Pattern 1

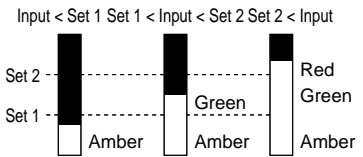

Pattern 2

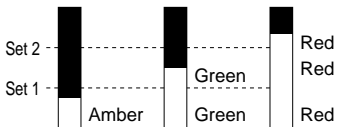

ADJUSTMENT PROCEDURE

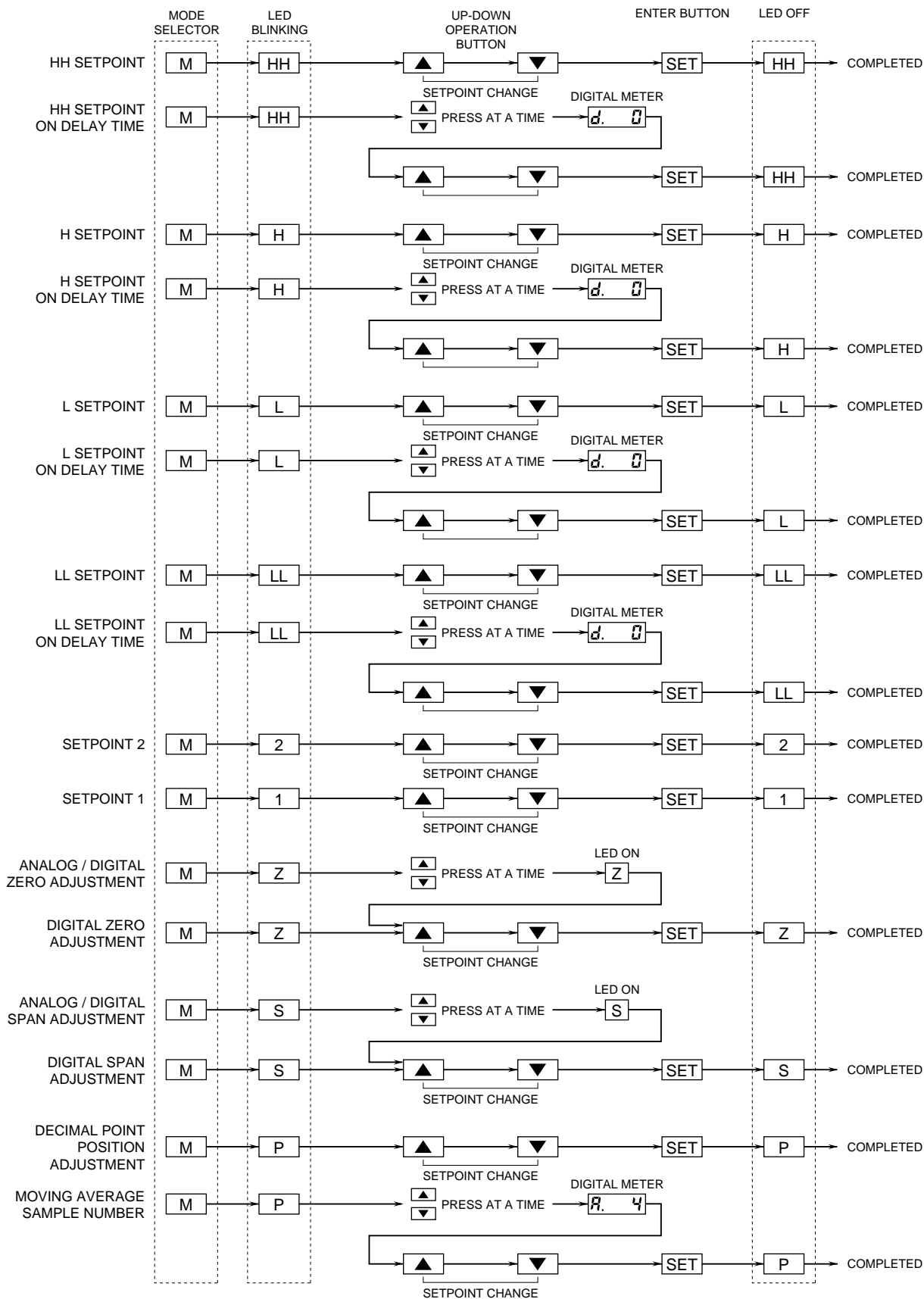

Remark 1: HH, H, L and LL setpoints are stored in the memory even the power is lost during operation.
If you need to adjust zero and span or digital meter, proceed before alarm setpoint adjustments.
Apply 0% and 100% input and adjust respective analog zero and span.

Remark 2: HH, H, L and LL Setpoint Adj. are deleted with model 48DV-0.
HH and LL Setpoint Adj. are deleted with model 48DV-2.

EXTERNAL DIMENSIONS & TERMINAL ASSIGNMENT mm (inch)

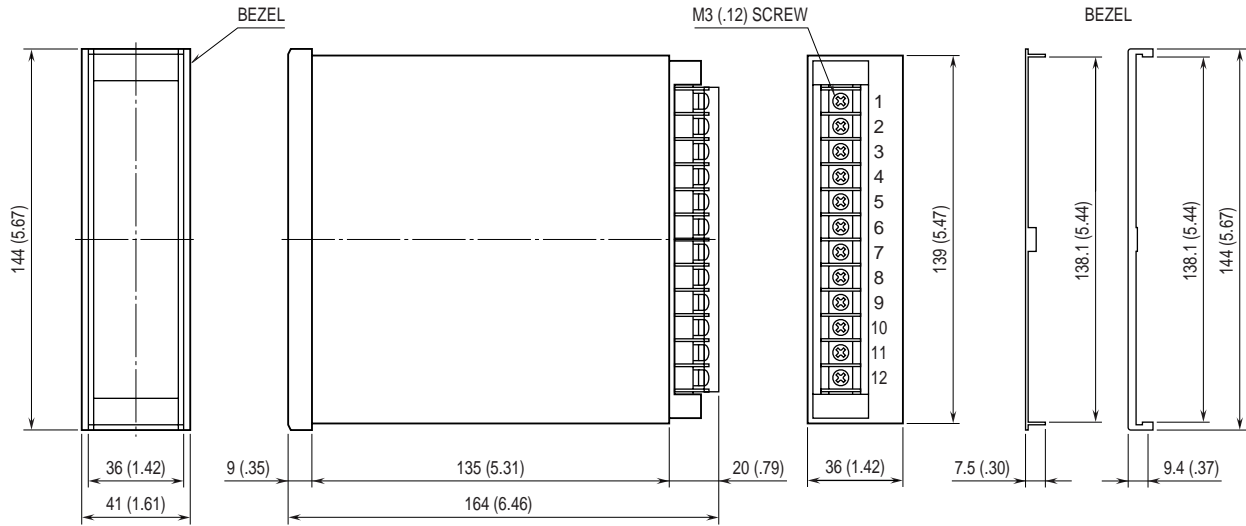

PANEL CUTOUT unit: mm

Panel thickness: 1.6 – 5.5 mm

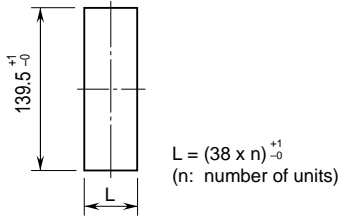

- Note 1. A bezel is required between units for high-density mounting.
- Note 2. Observe at the minimum of 5 cm above and below the units for heat dissipation.