

# Coaxial Low Noise Amplifier

## ZX60-05113LN+

50Ω 5 to 11 GHz

### The Big Deal

- Ultra low noise figure, 1.7 dB typ @ 8.5 GHz
- Low current consumption, 42 mA typ.
- High gain broadband performance
- Voltage regulated internally and reverse voltage protected



CASE STYLE: GC957

### Product Overview

Mini-Circuits' ZX60-05113LN+ is a wideband low noise connectorized amplifier providing a unique combination of low noise figure, high IP3 and flat gain over a very wide frequency range, supporting a wide range of sensitive, high-dynamic range receiver applications and many systems where high performance over wideband is needed. This design operates on a single 5 V supply and comes in a rugged, compact unibody case (0.74 x 0.75 x 0.46") with SMA connectors, making it an excellent candidate for tough operating conditions and crowded system layouts.

### Key Features

Feature	Advantages
Ultra-wideband with excellent gain flatness, $\pm 0.7$ dB typ. for 5-8.5 GHz	Enables a single amplifier to be used in a wide range of applications including microwave radios and C and X-band applications, instrumentation and more.
Low noise over the whole band	Enables lower system noise figure performance.
High gain, 22 dB typ.	Reduces the number of gain stages, lowering component count and overall system cost.
Low operating voltage, 5V	The amplifier features low operating voltage and low current consumption.
Rugged, unibody construction	Mini-Circuits unibody construction integrates the RF connector into the case body, providing high reliability and excellent survivability in critical applications.

#### Notes

A. Performance and quality attributes and conditions not expressly stated in this specification document are intended to be excluded and do not form a part of this specification document.

B. Electrical specifications and performance data contained in this specification document are based on Mini-Circuit's applicable established test performance criteria and measurement instructions.

C. The parts covered by this specification document are subject to Mini-Circuits standard limited warranty and terms and conditions (collectively, "Standard Terms"); Purchasers of this part are entitled to the rights and benefits contained therein. For a full statement of the Standard Terms and the exclusive rights and remedies thereunder, please visit Mini-Circuits' website at [www.minicircuits.com/MCLStore/terms.jsp](http://www.minicircuits.com/MCLStore/terms.jsp)



# Coaxial Low Noise Amplifier

## ZX60-05113LN+

50Ω 5 to 11 GHz

### Features

- Ultra low noise figure, 1.7 dB typ @ 8.5 GHz
- High gain 22 dB typ at 8.5 GHz
- Excellent Gain flatness,  $\pm 0.7$  dB over 5.0 to 8.5 GHz and 6V

### Applications

- Microwave radios
- C-band application
- X-band application
- Instrumentation and lab use



Generic photo used for illustration purposes only

CASE STYLE: GC957

Connectors	Model
SMA	ZX60-05113LN+

### +RoHS Compliant

The +Suffix identifies RoHS Compliance. See our web site for RoHS Compliance methodologies and qualifications

### Electrical Specifications at 25°C and 5V, unless noted

Parameter	Condition (GHz)	V <sub>DD</sub> =5.0			Units
		Min.	Typ.	Max.	
Frequency Range		0.5		11.0	GHz
Noise Figure	5.0-7.0		2.3		dB
	7.0-9.0		1.8		
	9.0-11.0		1.7		
Gain	5.0-7.0		22.2		dB
	7.0-9.0	17.5	21.4		
	9.0-11.0		20.1		
Input Return Loss	5.0-7.0		6.7		dB
	7.0-9.0		12.1		
	9.0-11.0		9.0		
Output Return Loss	5.0-7.0		13.0		dB
	7.0-9.0		17.0		
	9.0-11.0		11.5		
Output Power at 1dB Compression <sup>(1)</sup>	5.0-7.0		12.4		dBm
	7.0-9.0		13.0		
	9.0-11.0		13.0		
Output IP3	5.0-7.0		25.0		dBm
	7.0-9.0		24.5		
	9.0-11.0		24.0		
Device Operating Voltage (V <sub>DD</sub> )	—	4.9	5.0	9.0	V
Device Operating Current (I <sub>DD</sub> )			42	53	mA

1. Current increases at P1dB

2. OIP3 measured with 0 dBm tones and 1 MHz spacing.

### Notes

A. Performance and quality attributes and conditions not expressly stated in this specification document are intended to be excluded and do not form a part of this specification document.

B. Electrical specifications and performance data contained in this specification document are based on Mini-Circuit's applicable established test performance criteria and measurement instructions.

C. The parts covered by this specification document are subject to Mini-Circuits standard limited warranty and terms and conditions (collectively, "Standard Terms"); Purchasers of this part are entitled to the rights and benefits contained therein. For a full statement of the Standard Terms and the exclusive rights and remedies thereunder, please visit Mini-Circuits' website at [www.minicircuits.com/MCLStore/terms.jsp](http://www.minicircuits.com/MCLStore/terms.jsp)



## Absolute Maximum Ratings<sup>4</sup>

Parameter	Ratings
Operating Temperature (ground lead)	-40°C to 85°C
Storage Temperature	-55°C to 100°C
Total Power Dissipation	0.6 W
Input Power (CW), Vd=5V	17 dBm
DC Voltage	9V

4. Permanent damage may occur if any of these limits are exceeded.  
Electrical maximum ratings are not intended for continuous normal operation.

## Outline Drawing

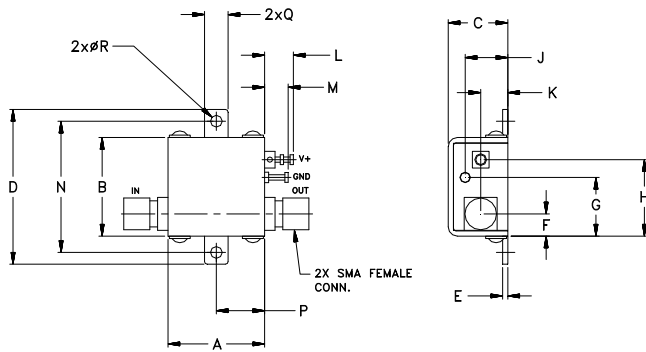

**!** NOTE: When soldering the DC connections, caution must be used to avoid overheating the DC terminal. See Application Note. [AN-40-010](#).

## Outline Dimensions (inch/mm)

A	B	C	D	E	F	G	H	J	K	L	M	N	P	Q	R	wt
.74	.75	.46	1.18	.04	.17	.45	.59	.33	.21	.22	.18	1.00	.37	.18	.106	grams
18.80	19.05	11.68	29.97	1.02	4.32	11.43	14.99	8.38	5.33	5.59	4.57	25.40	9.40	4.57	2.69	23.0

### Notes

- Performance and quality attributes and conditions not expressly stated in this specification document are intended to be excluded and do not form a part of this specification document.
- Electrical specifications and performance data contained in this specification document are based on Mini-Circuit's applicable established test performance criteria and measurement instructions.
- The parts covered by this specification document are subject to Mini-Circuits standard limited warranty and terms and conditions (collectively, "Standard Terms"); Purchasers of this part are entitled to the rights and benefits contained therein. For a full statement of the Standard Terms and the exclusive rights and remedies thereunder, please visit Mini-Circuits' website at [www.minicircuits.com/MCLStore/terms.jsp](http://www.minicircuits.com/MCLStore/terms.jsp)



FREQUENCY (MHz)	GAIN (dB)	DIRECTIVITY (dB)	VSWR (:1)		POWER OUT @1 dB COMPR. (dBm)	POWER OUT @3 dB COMPR. (dBm)	NF (dB)	IP3 (dBm)
			5V					
			IN	OUT				
5000	21.99	22.45	1.60	1.56	10.19	11.40	2.49	22.91
5400	22.26	20.60	1.15	1.58	10.65	12.19	2.39	23.70
5800	22.33	19.31	1.32	1.71	11.53	12.94	2.30	25.30
6200	22.29	18.35	1.42	1.72	11.72	13.18	2.21	25.26
6600	22.15	17.60	1.47	1.62	11.39	13.22	2.11	24.84
7000	21.97	17.06	1.49	1.41	11.77	13.39	2.05	25.14
7400	21.74	16.70	1.63	1.22	11.65	13.46	1.93	24.67
7800	21.49	16.51	1.79	1.15	12.08	13.72	1.83	25.11
8200	21.22	16.41	1.95	1.28	11.95	13.72	1.75	24.49
8600	20.95	16.36	2.05	1.43	12.36	13.88	1.71	24.73
9000	20.68	16.38	2.07	1.55	12.55	13.89	1.64	24.81
9400	20.34	16.54	2.00	1.59	12.52	13.64	1.65	24.67
9800	19.88	16.94	1.92	1.57	12.16	13.20	1.68	24.54
10200	19.26	17.66	1.90	1.64	12.32	13.16	1.78	24.72
11000	17.72	19.71	3.17	1.64	12.24	13.13	1.94	24.95

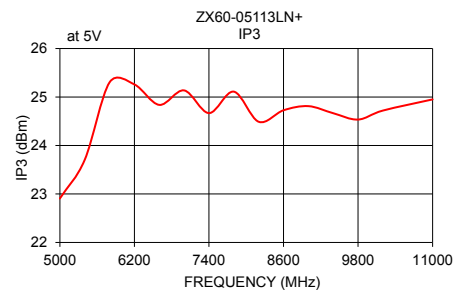
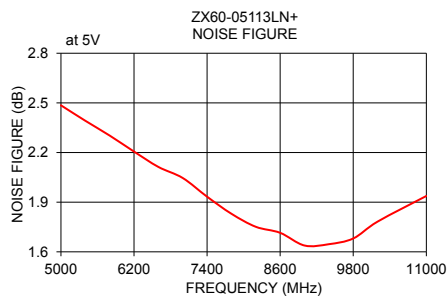
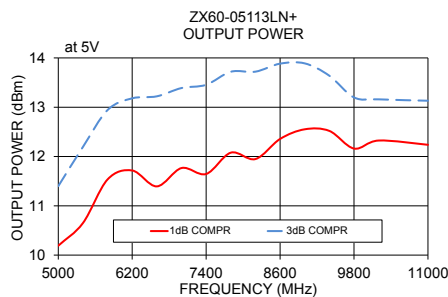
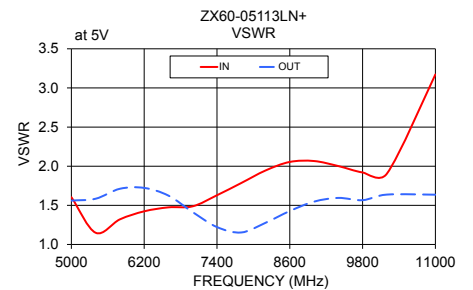
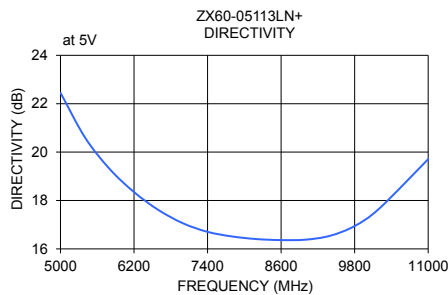
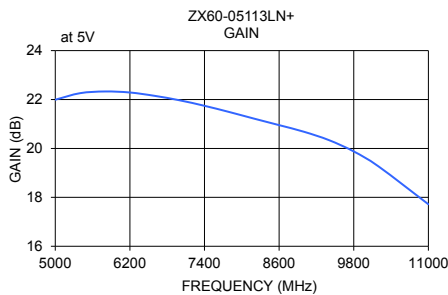

**Notes**

- A. Performance and quality attributes and conditions not expressly stated in this specification document are intended to be excluded and do not form a part of this specification document.
- B. Electrical specifications and performance data contained in this specification document are based on Mini-Circuit's applicable established test performance criteria and measurement instructions.
- C. The parts covered by this specification document are subject to Mini-Circuits standard limited warranty and terms and conditions (collectively, "Standard Terms"); Purchasers of this part are entitled to the rights and benefits contained therein. For a full statement of the Standard Terms and the exclusive rights and remedies thereunder, please visit Mini-Circuits' website at [www.minicircuits.com/MCLStore/terms.jsp](http://www.minicircuits.com/MCLStore/terms.jsp)

