

# RL-5012

## COMMON MODE TOROIDS VERTICAL MOUNT

### DESCRIPTION

- Vertical Mount Toroids

### ENVIRONMENTAL DATA

- Storage temperature range: -55°C to +130°C
- Operating temperature range: Contact Engineering

### PACKAGING INFORMATION

- Packaging information: pg. 495

### FEATURES & APPLICATIONS

- Effective in filtering supply lines having in-phase signals of equal amplitude
- Allows equipment to meet FCC and electrical radiation specifications
- Broad frequency ranges can be filtered
- Typical applications include: power line filter, suppress EMI in switched-mode, and power supplies
- Dielectric withstanding voltage rated at 2000 VAC line to line

Verify operation with sample in actual circuit. Order samples at [www.rencousa.com](http://www.rencousa.com).

### MECHANICAL DIMENSIONS

U.S. Standard (mm)

PART NUMBER	A (MIN.)	B	C (MAX.)	D (MAX.)	E (MAX.)	F (MAX.)
RL-5012	0.250 (6.35)	0.90 (22.86)	1.10 (27.94)	0.20 (5.08)	1.55 (39.37)	1.45 (36.83)

PART NUMBER	PART WEIGHT
RL-5012	29.0g (1.02oz)

G	H (MAX.)	I (REF.)	J (REF.)
0.60 (15.24)	0.90 (22.86)	0.90 (22.86)	0.60 (15.24)

FRONT VIEW

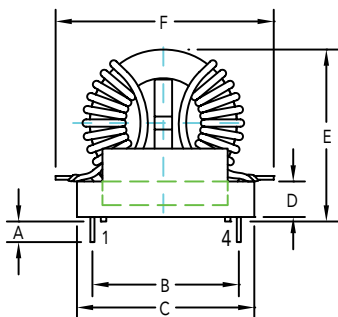

SIDE VIEW

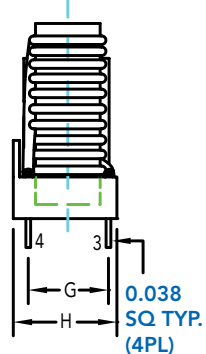

RECOMMENDED LAND PATTERN

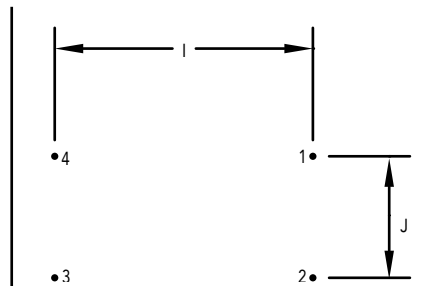

SCHEMATIC

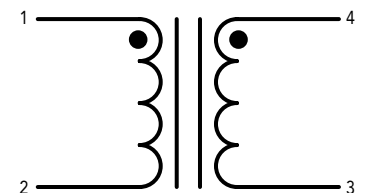

**RENCO ELECTRONICS INC.**

595 International Place, Rockledge, FL 32955-4200 USA • [www.rencousa.com](http://www.rencousa.com) • ISO 9001 Certified  
Toll Free Engineering Hot Line: 800.645.5828 • P: 321.637.1000 • F: 321.637.1600



# RL-5012

Renco Part No. RL-5012	Inductance (mH)-0+60%	DCR Max. (Ohms)	Leakage Inductance ( $\mu$ H) Typ.
RL-5012-7.5-1	7.5	0.306	81.0
RL-5012-13-1	13.0	0.400	190.0
RL-5012-3.8-2	3.8	0.104	43.0
RL-5012-6.5-2	6.5	0.143	105.0
RL-5012-1.9-4	1.9	0.042	20.5
RL-5012-3.3-4	3.3	0.054	54.0
RL-5012-1.5-6	1.5	0.030	17.0
RL-5012-2.6-6	2.6	0.040	40.0
RL-5012-0.9-9	0.9	0.016	11.2
RL-5012-1.5-9	1.5	0.021	22.0
RL-5012-0.7-12	0.7	0.012	8.0
RL-5012-1.2-12	1.2	0.016	17.0
RL-5012-0.5-15	0.5	0.008	10.0
RL-5012-0.8-15	0.8	0.009	14.0

**NOTES:**

1. ELECTRICAL SPECIFICATIONS MEASURED AT 25°C
2. ALL TERMINALS 0.038 SQUARE (WILL FIT PRINTED BOARD HOLE = #16 AWG)
3. INDUCTANCE TESTED AT 10 kHz, 0.25 Vrms

