

ITS 500 00 Series
Front Panel Mount Square Flange Receptacle
Assembly for Jacketed Cables

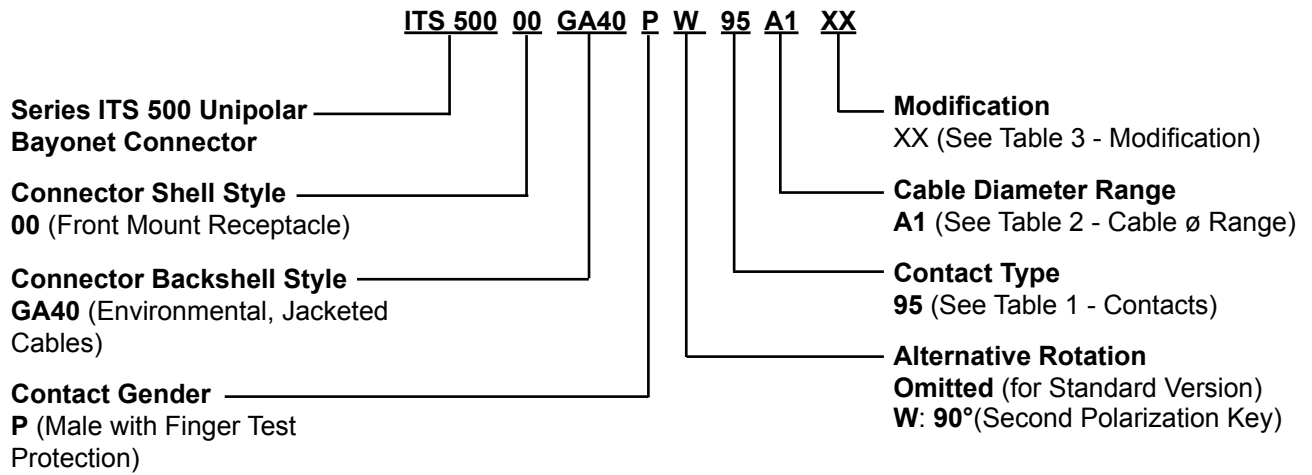

Application Notes:

- Front mount receptacle with backshell for jacketed cable. RoHS Compliant.
- Working voltage: 3000 Vcc. Test voltage: 12000 Vcc (1 min.).
- Water proof : IP67 level (coupled connectors).
- Contact resistance: 0.2 mOhm Max
- Temperature range: -55 +125°C.
- Contact: copper alloy with silver plating.
- Insulator: black thermoplastic resin according with UL94V0-NFF16-102:I2F1 (Exigency 4).
- Shells: Aluminium alloy with electrodeposited black paint.

ITS 500 00 Series
Front Panel Mount Square Flange Receptacle
Assembly for Jacketed Cables

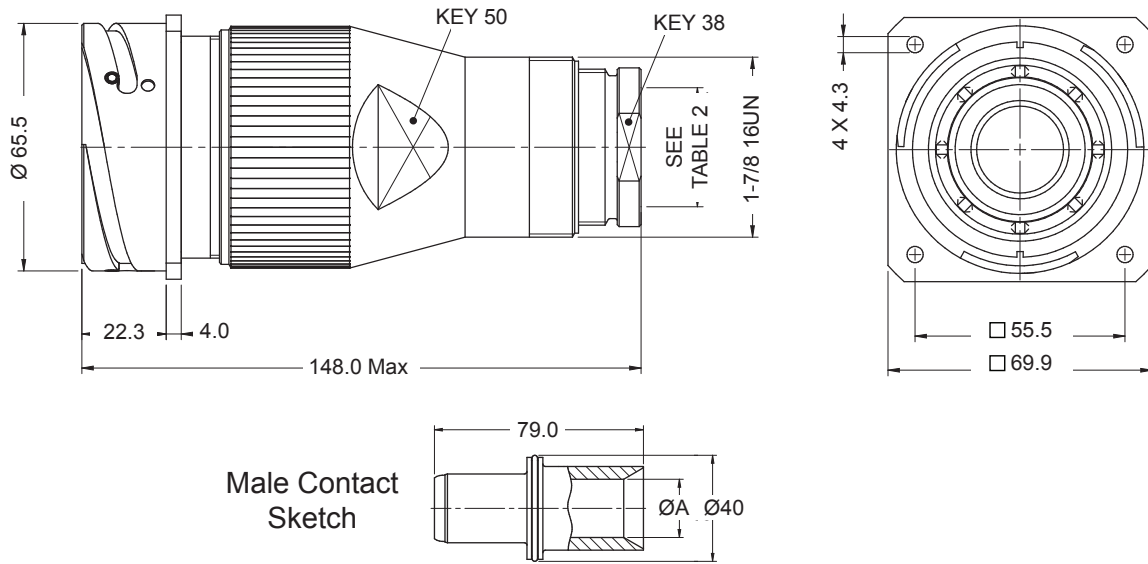

TABLE 1 - CONTACTS

Contact Type	Contact Gender	Contact P/N	Cable AWG *	Cable Section (mmq)	Working Current (A) **	Max Current (A) **	Conductor Min. Ø (mm)	Conductor Max Ø (mm)	Crimp Bucket - ØA - (mm)
95	Male	ITS 500-1420PG10	3/0	95	350	400	12.5	14.0	14.2
120	Male	ITS500-1600PG10	-	120	450	500	14.2	15.5	16.0
262 MCM	Male	ITS500-1750PG10	262 MCM	-	450	520	15.8	16.5	17.5
150	Male	ITS500-1750PG10	-	150	550	630	15.8	16.5	17.5
444 MCM	Male	ITS500-2200PG10	444 MCM	-	640	735	19.6	21.1	22.0
240	Male	ITS500-2200PG10	-	240	750	800	19.6	21.1	22.0
535 MCM	Male	ITS500-2680PG10	535 MCM	-	750	800	21.0	24.5	26.8

* For different cable dimensions, please contact the factory.

** Related to cables ampacity.

TABLE 2 - CABLE Ø RANGE

Cable Range Code	Min. Cable Ø	Max Cable Ø
A1	13	23
A2	19	29
A3	26	32

TABLE 3 - MODIFICATION CODES

Name	Modification
Omitted	Standard
B0	Connector Less Contacts
F7	Conductive Black Plating
K1	Stainless Receptacle
K2	Stainless Plug Shell for Straight Plug

