

40V N-CHANNEL ENHANCEMENT MODE MOSFET

MAIN CHARACTERISTICS

I_D	100A
V_{DSS}	40V
$R_{DS(on)-typ}(@V_{GS}=10V)$	< 6.5mΩ (Type:4.5 mΩ)

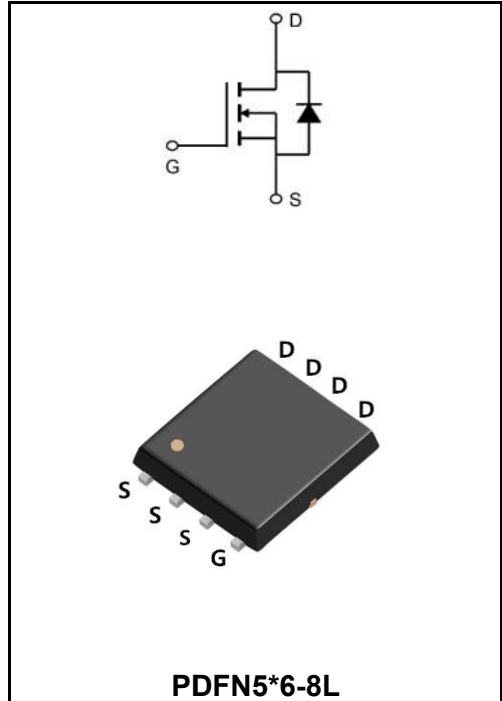

Application

- ◆ Battery protection
- ◆ Load switch
- ◆ Uninterruptible power supply



Product Specification Classification

Part Number	Package	Marking	Pack
YFW85N04NF	PDFN5*6-8L	YFW 85N04NF XXXXX	5000PCS/Tape

Maximum Ratings at Tc=25°C unless otherwise specified

Characteristics	Symbols	Value	Units
Drain-Source Voltage	V_{DS}	40	V
Gate - Source Voltage	V_{GS}	±20	V
Continuous Drain Current, V_{GS} @ 10V ¹ @T _C =25°C	I_D	85	A
Continuous Drain Current, V_{GS} @ 10V ¹ @T _C =100°C	I_D	58	A
Pulsed Drain Current ²	I_{DM}	150	A
Single Pulse Avalanche Energy ³	E_{AS}	110.5	mJ
Avalanche Current	I_{AS}	47	A
Total Power Dissipation ⁴ @T _C =25°C	P_D	52.1	W
Storage Temperature Range	T_{STG}	-55 to +150	°C
Operating Junction Temperature Range	T_J	-55 to +150	°C
Thermal Resistance Junction-Ambient ¹	$R_{\theta JA}$	62	°C/W
Thermal Resistance Junction-Case ¹	$R_{\theta JC}$	2.4	°C/W

Maximum Ratings at Tc=25°C unless otherwise specified

Characteristics	Test Condition	Symbols	Min	Typ	Max	Units
Drain-Source Breakdown Voltage	$V_{GS}=0V, I_D=250\mu A$	BV_{DSS}	40	-	-	V
Static Drain-Source on-Resistance ²	$V_{GS}=10V, I_D=10A$	$R_{DS(ON)}$	-	4.5	6.5	mΩ
	$V_{GS}=4.5V, I_D=5A$		-	6.4	8.5	
Gate -Threshold Voltage	$V_{DS}=V_{GS}, I_D=250\mu A$	$V_{GS(th)}$	1.0	-	2.5	V
Drain -Source Leakage Current	$V_{DS}=32V, V_{GS}=0V, T_J=25^\circ C$	I_{DSS}	-	-	1	μA
	$V_{DS}=32V, V_{GS}=0V, T_J=55^\circ C$		-	-	5	
Gate-Source Leakage Current	$V_{GS}=\pm 20V, V_{DS}=0V$	I_{GSS}	-	-	±100	nA
Forward Transconductance	$V_{DS}=10V, I_D=5A$	g_{FS}	-	27	-	S
Total Gate Charge(4.5V)	$V_{DS}=20V$ $V_{GS}=4.5V$ $I_D=10A$	Q_g	-	20	-	nC
Gate-Source Charge		Q_{GS}	-	5.8	-	
Gate-Drain Charge		Q_{gd}	-	9.5	-	
Turn-on delay time	$V_{DD}=15V$ $V_{GS}=10V$ $R_G=3.3\Omega$ $I_D=1A$	$t_{d(on)}$	-	15.2	-	ns
Rise Time		T_r	-	8.8	-	
Turn-Off Delay Time		$t_{d(OFF)}$	-	74	-	
Fall Time		t_f	-	7	-	
Input Capacitance	$V_{DS}=15V$ $V_{GS}=0V$ $f=1.0MHz$	C_{iss}	-	2354	-	pF
Output Capacitance		C_{oss}	-	215	-	
Reverse Transfer Capacitance		C_{rss}	-	175	-	
Continuous Source Current ^{1,5}	$V_G=V_D=0V, \text{ Force Current}$	I_S	-	-	70	A
Diode Forward Voltage ²	$V_{GS}=0V, I_S=1A, T_J=25^\circ C$	V_{SD}	-	-	1	V

Note :

- 1.The data tested by surface mounted on a 1 inch² FR-4 board with 2OZ copper.
- 2.The data tested by pulsed , pulse width $\leq 300\mu s$, duty cycle $\leq 2\%$
- 3.The EAS data shows Max. rating . The test condition is $V_{DD}=25V, V_{GS}=10V, L=0.1mH, I_{AS}=47A$
- 4.The power dissipation is limited by 150°C junction temperature
- 5.The data is theoretically the same as ID and IDM , in real applications , should be limited by total power dissipation.

Ratings and Characteristic Curves

Typical Characteristics

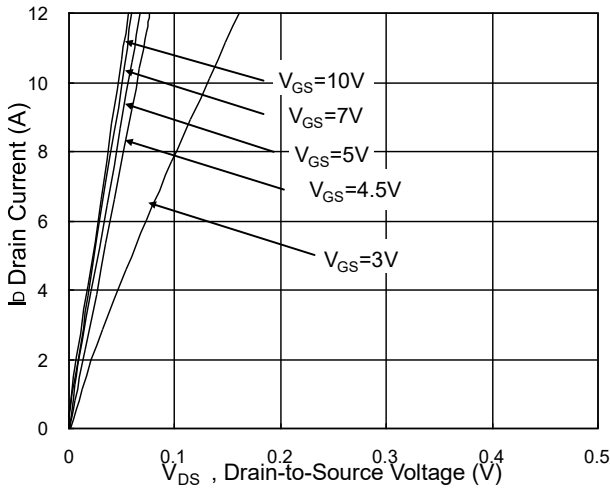

Fig.1 Typical Output Characteristics

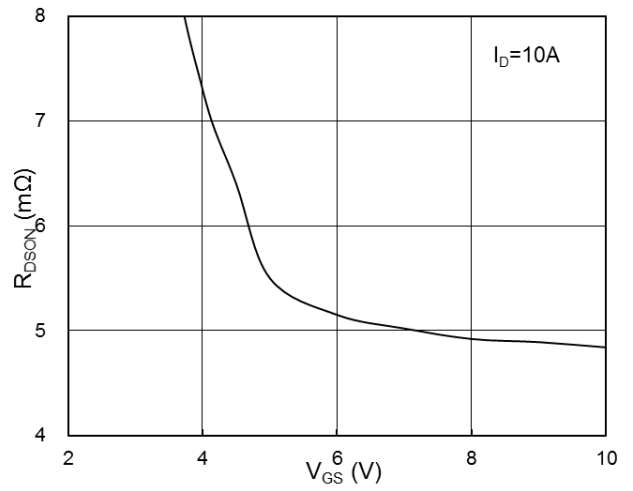

Fig.2 On-Resistance vs. G-S Voltage

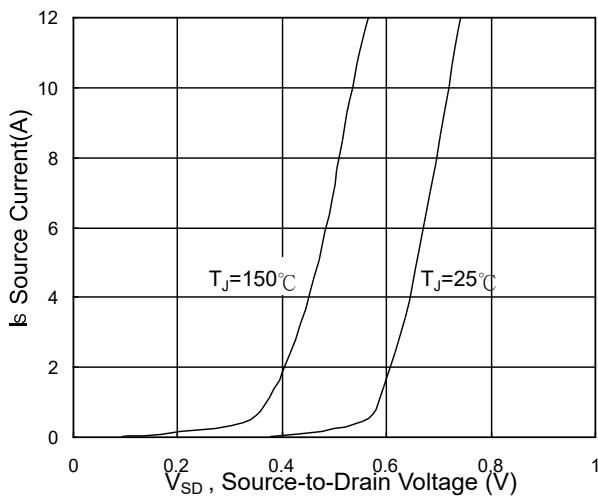

Fig.3 Forward Characteristics of Reverse

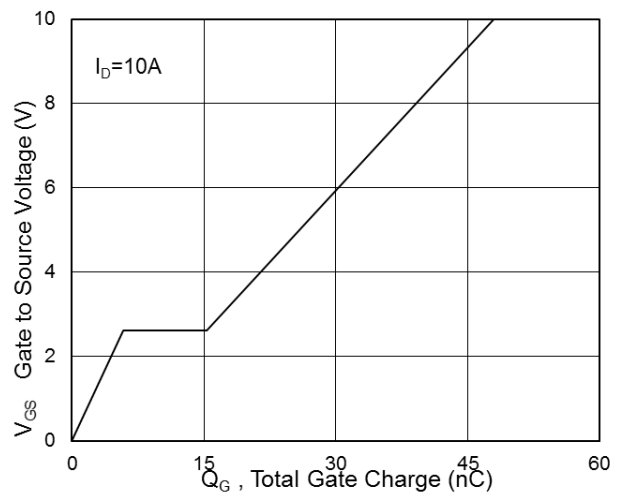

Fig.4 Gate-Charge Characteristics

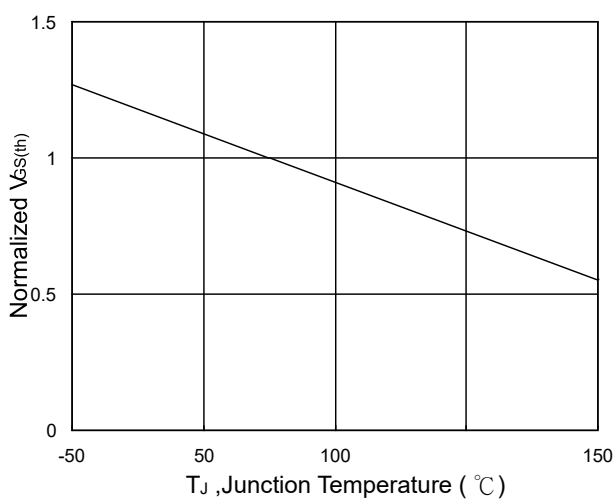

Fig.5 Normalized $V_{GS(th)}$ vs. T_J

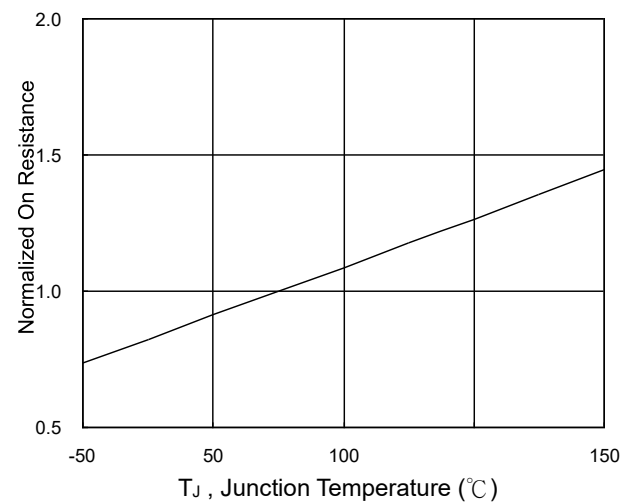

Fig.6 Normalized $R_{DS(on)}$ vs. T_J

Ratings and Characteristic Curves

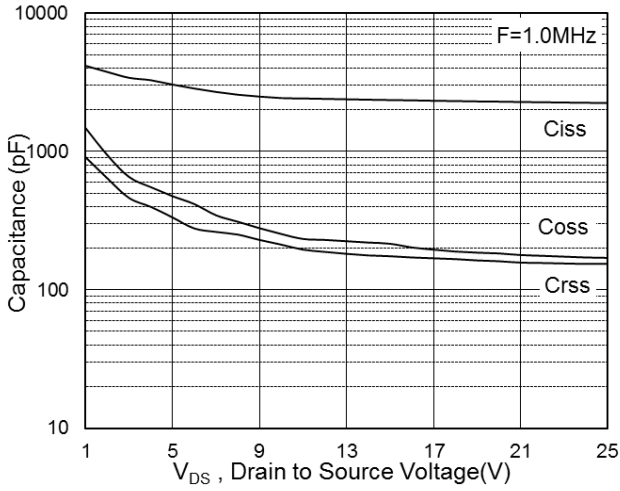

Fig.7 Capacitance

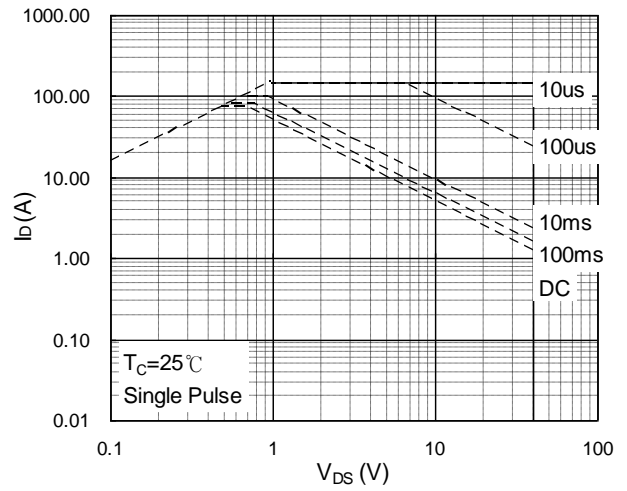

Fig.8 Safe Operating Area

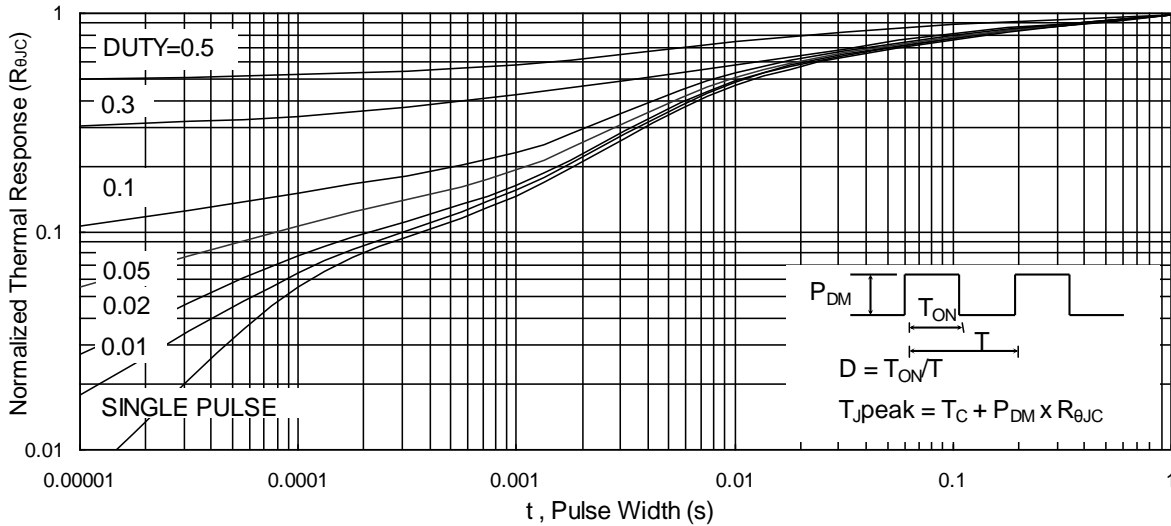

Fig.9 Normalized Maximum Transient Thermal Impedance

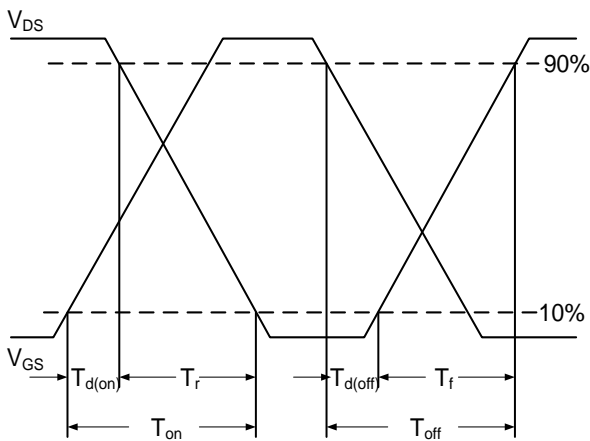

Fig.10 Switching Time Waveform

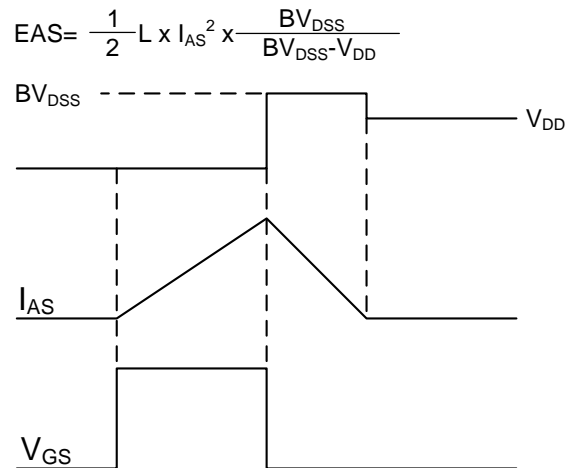
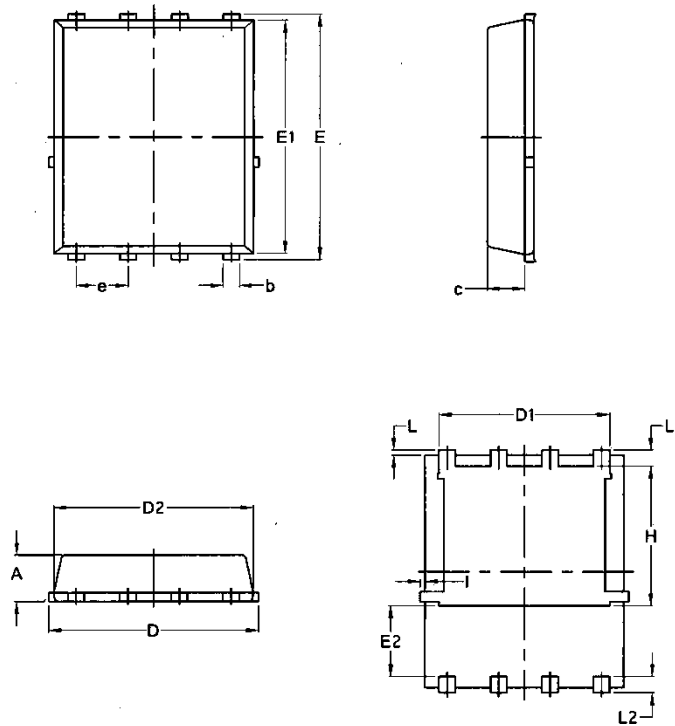

Fig.11 Unclamped Inductive Switching Wave

PDFN5*6-8L



Symbol	Common			
	mm		Inch	
	Min	Max	Min	Max
A	1.03	1.17	0.0406	0.0461
b	0.34	0.48	0.0134	0.0189
c	0.824	0.0970	0.0324	0.082
D	4.80	5.40	0.1890	0.2126
D1	4.11	4.31	0.1618	0.1697
D2	4.80	5.00	0.1890	0.1969
E	5.95	6.15	0.2343	0.2421
E1	5.65	5.85	0.2224	0.2303
E2	1.60	/	0.0630	/
e	1.27 BSC		0.05 BSC	
L	0.05	0.25	0.0020	0.0098
L1	0.38	0.50	0.0150	0.0197
L2	0.38	0.50	0.0150	0.0197
H	3.30	3.50	0.1299	0.1378
I	/	0.18	/	0.0070