

KGEA-BFCWX

103x20x9 mm (33 μ H – 500 μ H)

Emitter Antenna housing plastic base-potted and outside connector unsealed & sealed.

Characteristics

The antenna KGEA-BFCWX is designed for emission of a LF field to allow hands free access towards the Customer Device Identification for automotive application. This type antenna is inserted in the vehicle being integrated into the Access and Start Hand Free subsystem for requirements Passive Entry and Remote keyless Go System. Housing plastic base (materials PBT, PA-66 or ABS) assuring extreme conditions of humidity, liquids, substance and extreme environments. The antenna concept is similar to KGEA-BFCR series, but smaller in size.

The connector (sealed and unsealed) is optional and it can be customized to required features. Designed to allow long emitting-reading distances in the smallest volume.

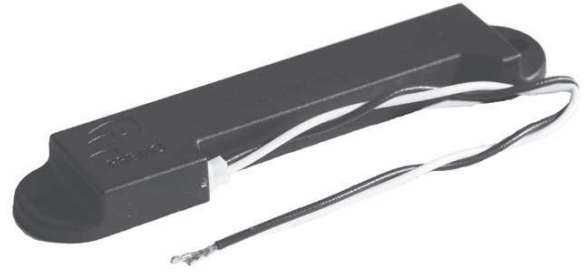

PKE emitter antennas

- Ideally used in keyless smart entry system
- Transmitting low frequency LF (20kHz, 125kHz and 134kHz).
- Low tolerances in the resonance frequency LC
- High stability in temperature (-40°C up to +85°C).
- Connector located outside assembly housing plastic base (Optional).
- Long reading distances and average current 2-4App.
- Strong anchor points which provide an easy assembly and will ensure mechanical robustness.
- Custom LCR value under demand.

Mechanical dimensions

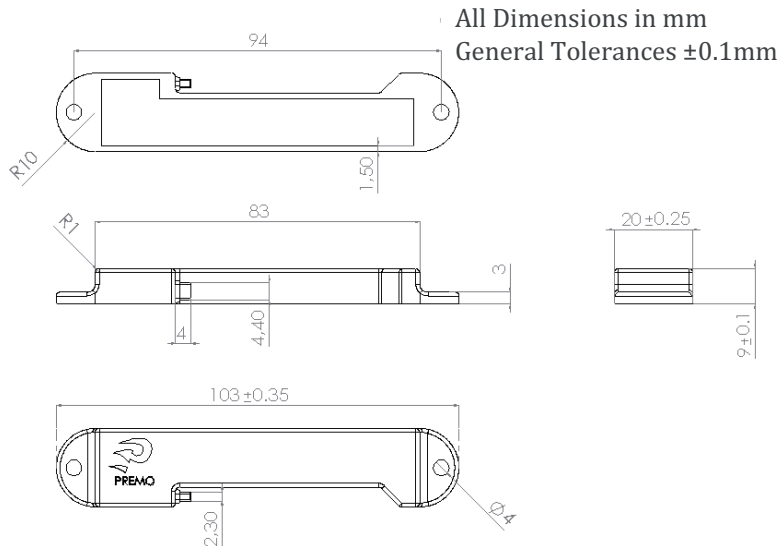

Electrical diagram

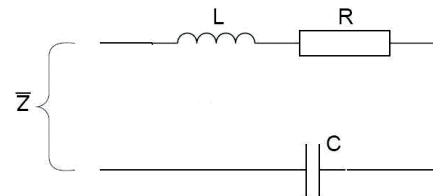

- L: Ferrite core coil inductance
- R: Copper resistance and connection
- C: Tuning internal capacitor NPO
- Rdc: Optional parallel resistor
- Z: External impedance

Nomenclature description

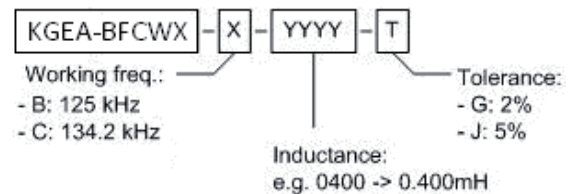

Electrical specifications

P/N	L (mH)	Cres (nF)	Q	SRF (MHz)	Freq. (kHz)
KGEA-BFCWX-B-0108J	0.108	15	>90	>3	125@
KGEA-BFCWX-B-0345J	0.345	4.7	>115	>3	125@
KGEA-BFCWX-B-0500J	0.500	3.3	>115	>3	125@
KGEA-BFCWX-C-0207J	0.207	6.8	>100	>3	134,2@
KGEA-BFCWX-C-0426J	0.426	3.3	>100	>3	134,2@

The specification chart is a reference guide for the most common required values at working frequencies of 125 kHz, 20 kHz and 134.2 kHz. Any other inductance value at LF or tighter tolerances can be provided. Please contact our sales department for any inquiry.