

LOC		DIST		REVISIONS			
A	66	P	LTM	DESCRIPTION	DATE	OWN	APVD
		-	-	SEE SHEET 1	-	-	-

FEED TYPE MECHANICAL

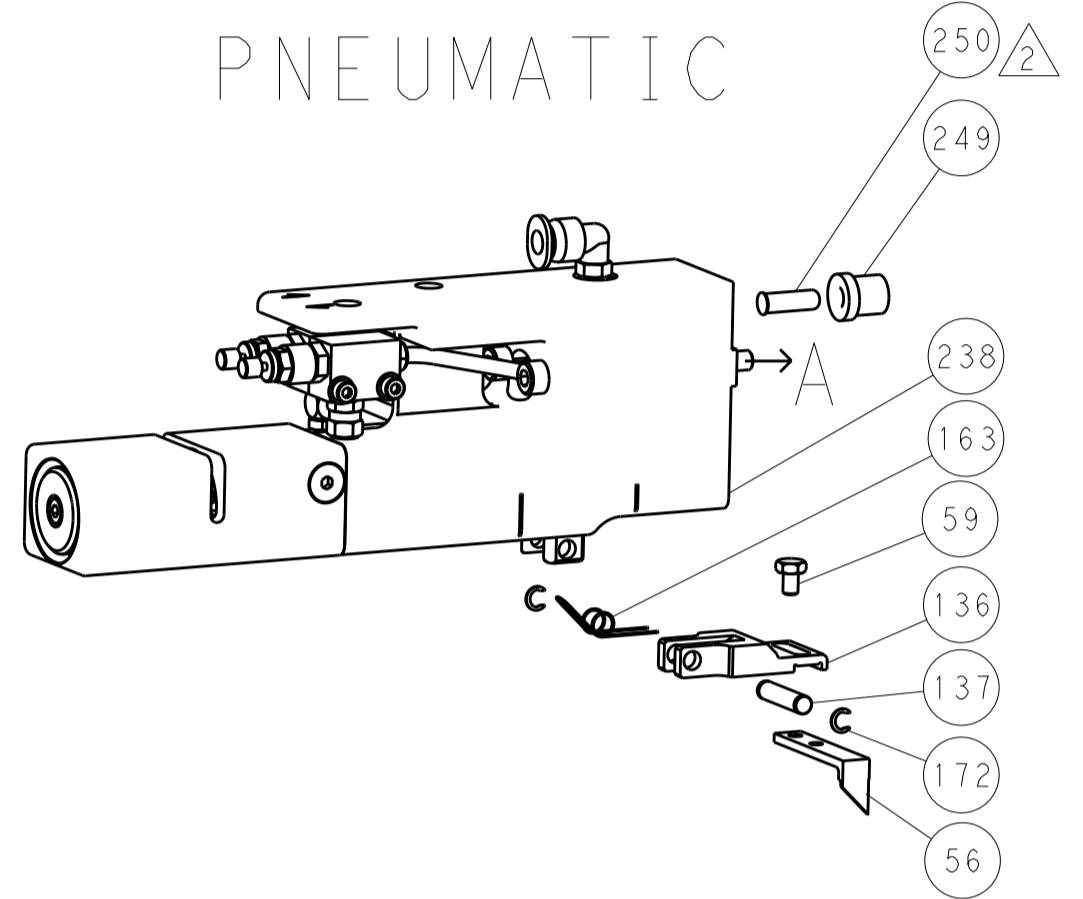

PNEUMATIC



SERVO LATCH PLATE



CAM POSITIONS

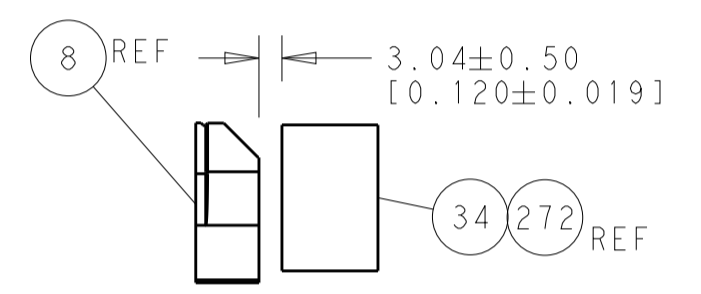
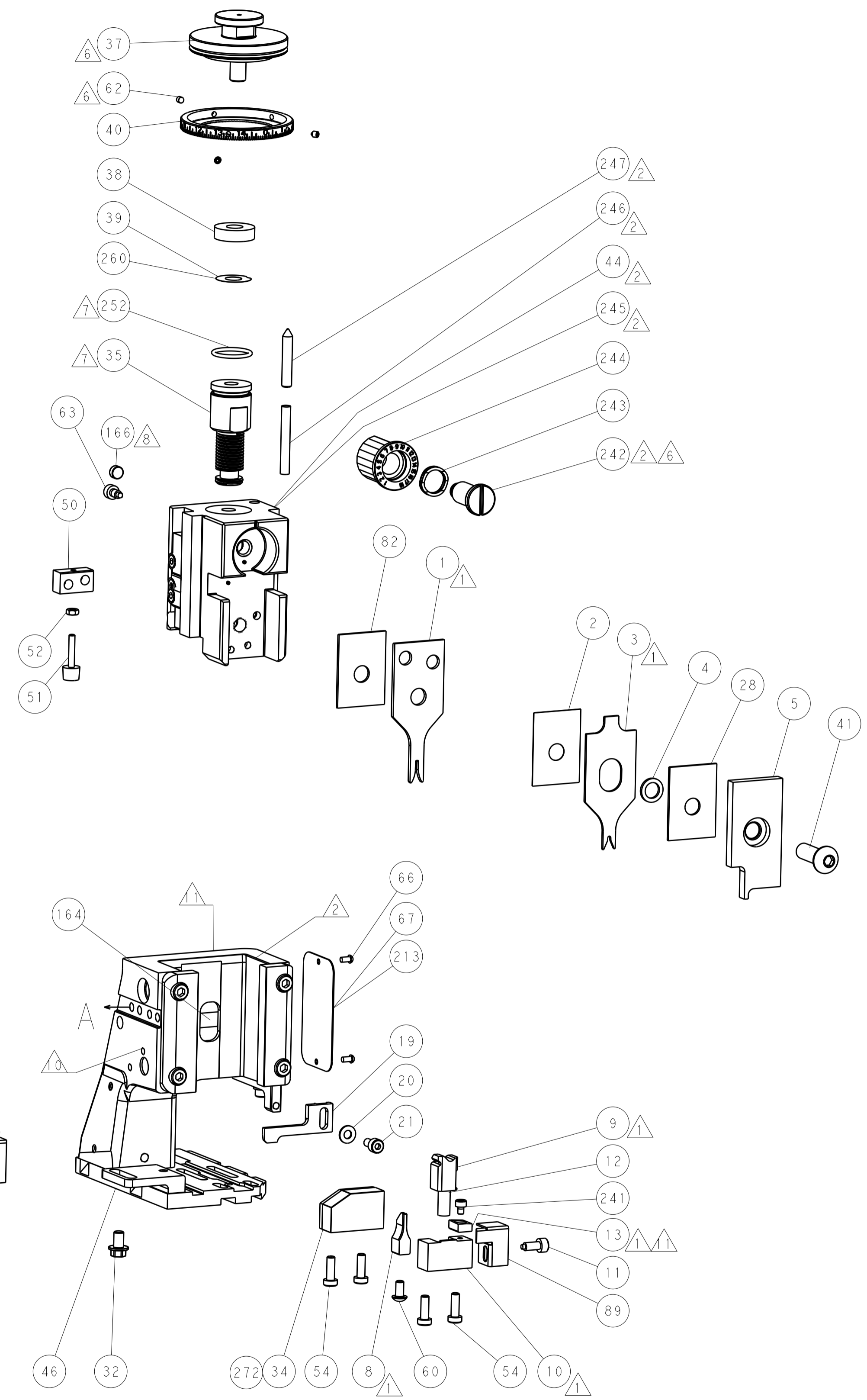

TERMINAL SUPPORT LOCATION

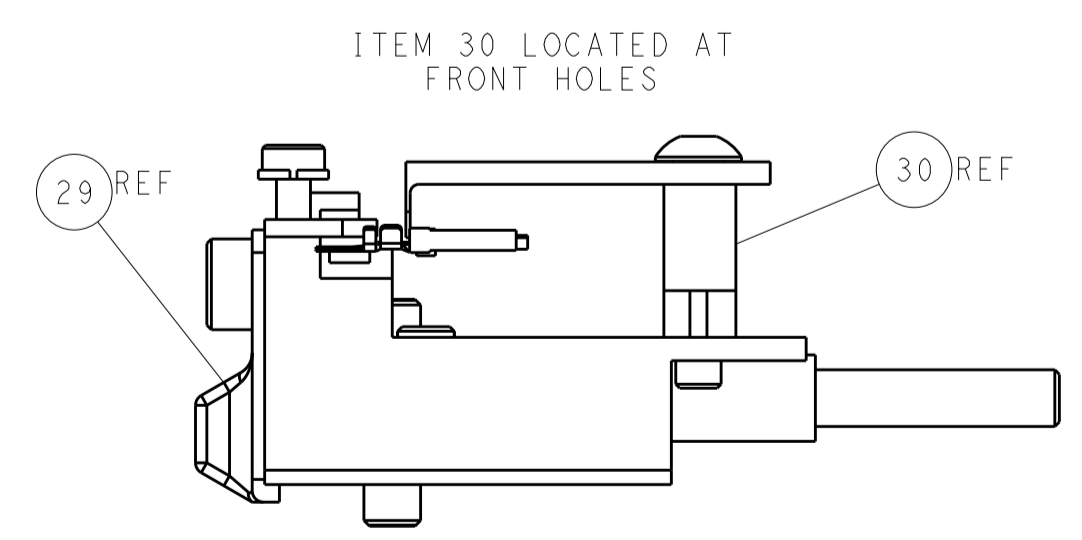

FEED TRACK POSITION GUIDE BY WIRE BARREL

ATLANTIC VERSION
 Shown on sheets 1 of 4 & 2 of 4
 (Pacific version shown on sheets 3 of 4 & 4 of 4)

DIMENSIONS:		TOLERANCES UNLESS OTHERWISE SPECIFIED:		DWN: EL_GROSS 29OCT2013		TE Connectivity	
mm	0 PLC ±0.5	1 PLC ±0.5	2 PLC ±0.13	3 PLC ±0.013	4 PLC ±0.001	APVD: T.ELBIN 29OCT2013	Harrisburg, PA 17105-3608
MATERIAL:		FINISH:		NAME: Ocean Side Feed Applicator		RESTRICTED TO:	
Customer Accessible Production Drawing		SCALE: 1:2		SHEET 2 of 4		REV A	

LOC		DIST		REVISIONS			
A	66	P	LTM	DESCRIPTION	DATE	DWN	APVD
		-		SEE SHEET 1			

FEED TYPE MECHANICAL



PNEUMATIC

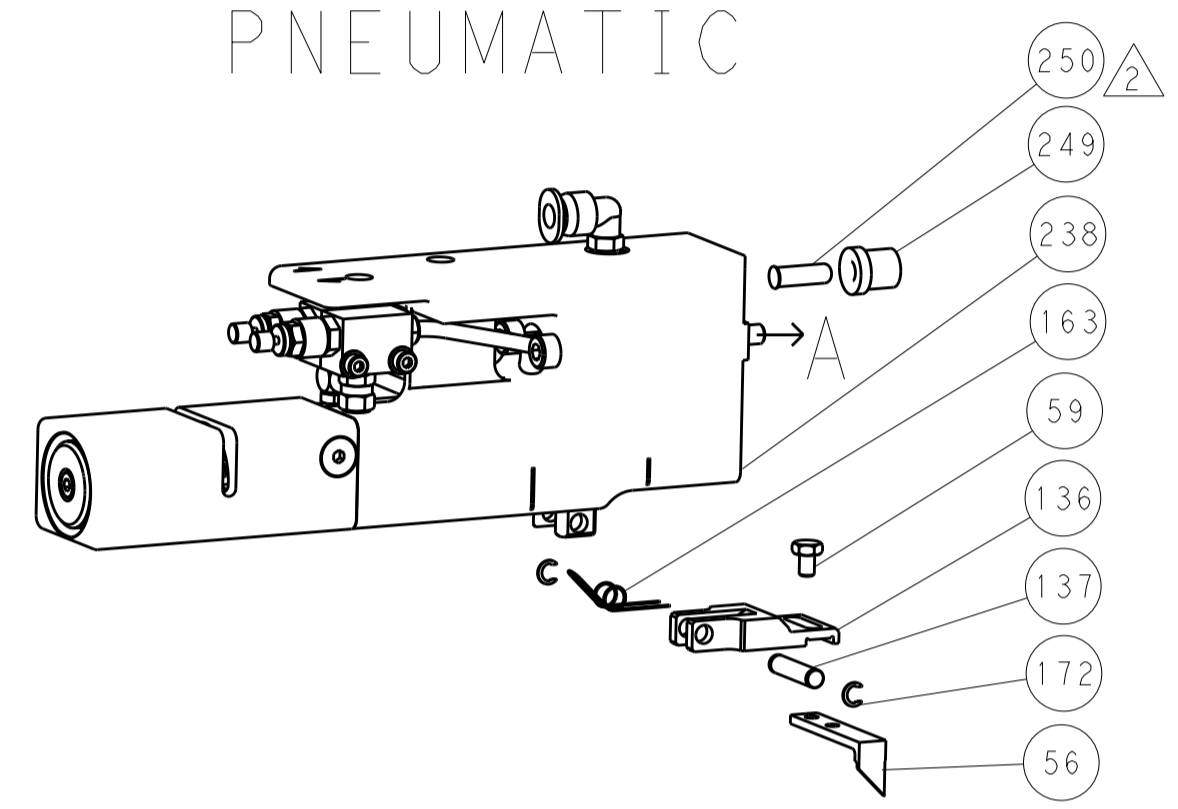

SERVO LATCH PLATE



CAM POSITIONS

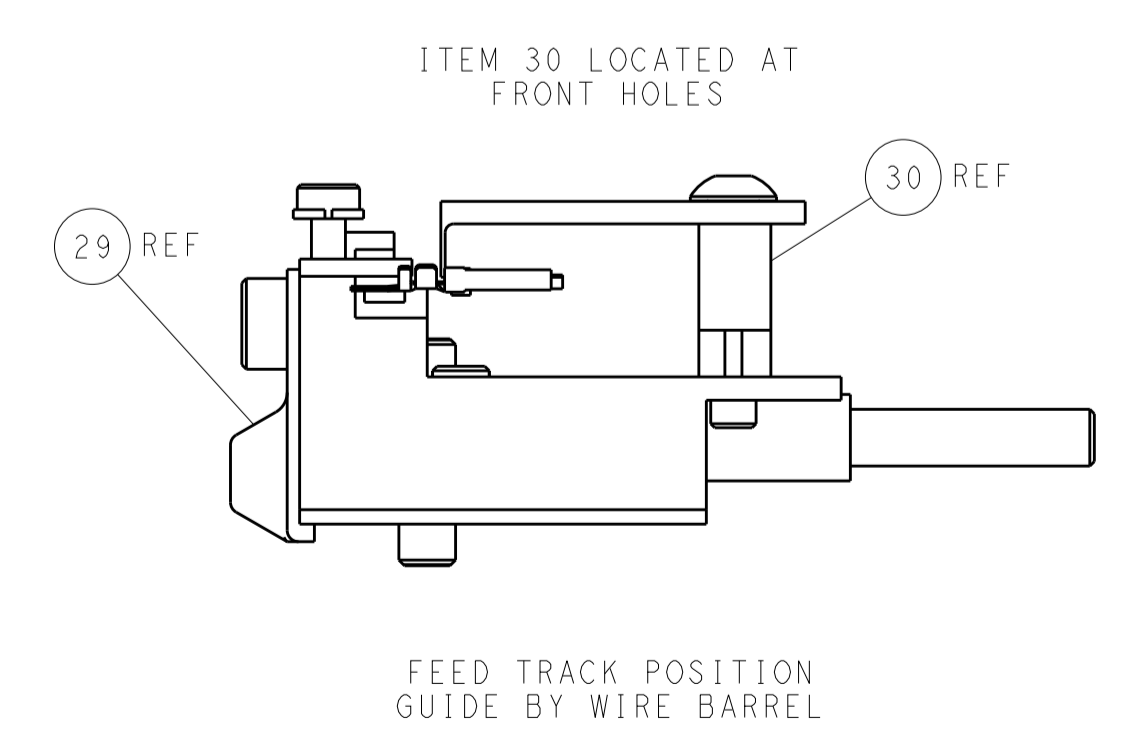
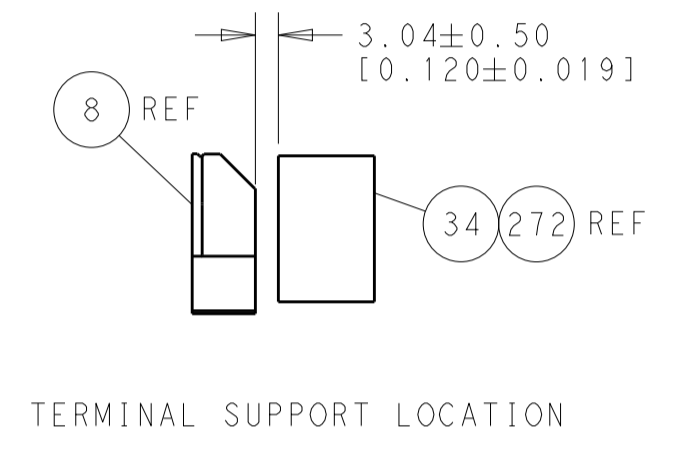
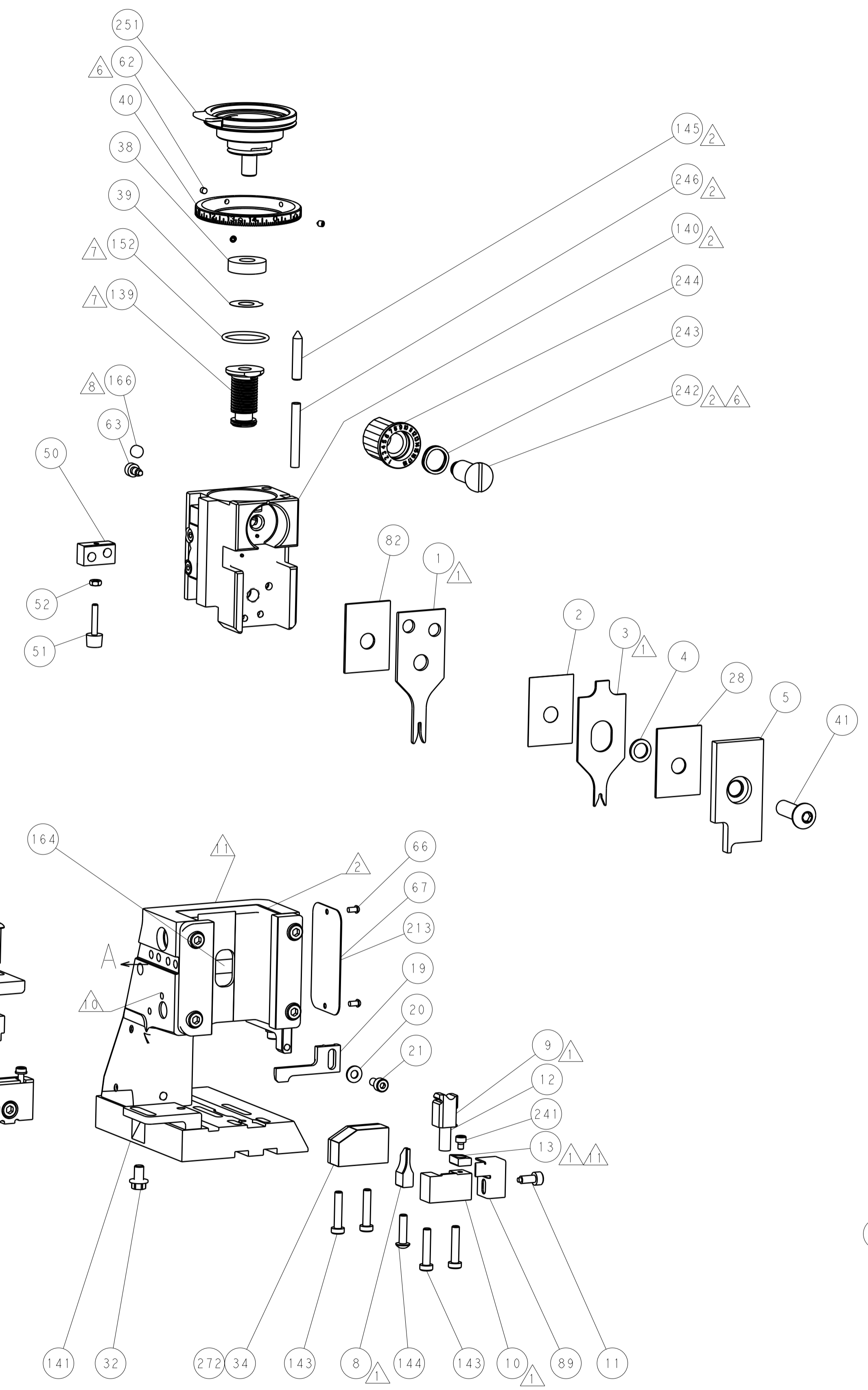

PACIFIC VERSION
 Shown on sheets 3 of 4 & 4 of 4
 (Atlantic version shown on sheets 1 of 4 & 2 of 4)

<small>THIS DRAWING IS UNPUBLISHED. RELEASED FOR PUBLICATION. IT IS THE PROPERTY OF TYCO ELECTRONICS CORPORATION. IT IS TO BE USED ONLY FOR THE PURPOSES AND IN THE QUANTITIES SPECIFIED IN THE ORDER. NO PARTS OF THIS DRAWING ARE TO BE REPRODUCED OR TRANSMITTED IN ANY FORM OR BY ANY MEANS, ELECTRONIC OR MECHANICAL, INCLUDING PHOTOCOPYING, RECORDING, OR BY ANY INFORMATION STORAGE AND RETRIEVAL SYSTEM, WITHOUT THE WRITTEN PERMISSION OF TYCO ELECTRONICS CORPORATION.</small>		DWN: L.GROSS 29OCT2013 CHK: T.ELBIN 29OCT2013 APVD: M.CLEFFORD 29OCT2013	NAME: Ocean Side Feed Applicator SIZE: A CAGE CODE: 00779 DRAWING NO: 2266143	RESTRICTED TO: - SCALE: 1:2 SHEET: 4 OF 4 REV: A
DIMENSIONS: mm TOLERANCES UNLESS OTHERWISE SPECIFIED: 0 PLC ±.5 1 PLC ±0.5 2 PLC ±0.13 3 PLC ±0.013 4 PLC ±0.001 ANGLES ±.1	MATERIAL: - FINISH: -	PRODUCT SPEC: - APPLICATION SPEC: - WEIGHT: -	CUSTOMER ACCESSIBLE PRODUCTION DRAWING	DATE: - DWN: - APVD: -