

1. Mechanical Dimensions:

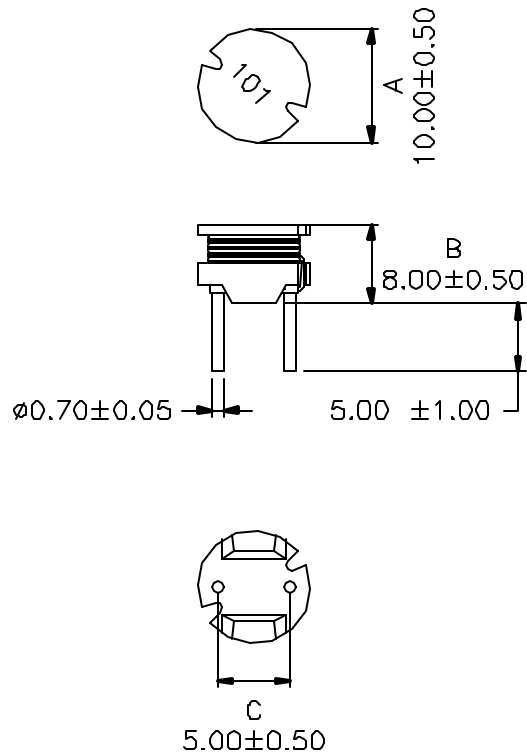

2. Schematic:

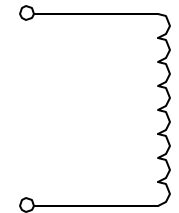

3. Electrical Specifications: @25°C

OCL: $100\mu\text{H} \pm 10\%$ @1.0KHz, 0.25V
 RATED CURRENT: 2.01ADC
 DCR: 0.23 Ohms Max

Note

1. Solderability: Leads shall meet MIL-STD-202, Method 208D for solderability.
2. Flammability: UL94V-0,
3. ASTM oxygen index: $> 28\%$,
4. Operating Temperature Range: All listed parameters are to be within tolerance from -40°C to $+85^\circ\text{C}$

DOC. REV: A/1

XFMRs Inc	Title: INDUCTOR		
	UNLESS OTHERWISE SPECIFIED	P/N: RLXF0810-101K	REV. A
TOLERANCES: N/A	DWN.	廖玉坤	Nov-14-00
Dimensions in MM	CHK.	李清儿	Nov-14-00
SHEET 1 OF 1	APP.	Joe Huff	Nov-14-00