

## 25 Amp Minature PCB Power Relay

## PC454



### FEATURES

- 25 Amp contact capacity
- 80 Amp Inrush
- 3.6 KV dielectric strength between coil and contacts
- .250 quick connect terminals for load
- 1 Hp @ 250 VAC
- Meets UL 873 spacing
- UL Class "F" insulation available



File # E93379

### UL/CUR RATINGS

Load Type	All Forms All Contacts
Resistive	25 Amps @ 120 VAC, 277 VAC & 30 VDC
Motor	1 1/2 Hp @ 250 VAC, 1 Hp @ 125 VAC
Maximum switched power	6380 VA, 750 W
Maximum switched voltage	300 VAC, 30 VDC

### CONTACT DATA

Material		AgSnO (Silver Tin Oxide)
Initial Contact Resistance		30 milliohms max @ 0.1A, 6VDC
Service Life	Mechanical	1 X 10 <sup>7</sup> Operations
	Electrical	1 X 10 <sup>5</sup> Operations

### CHARACTERISTICS

Operate Time	20 ms. Max.
Release Time	10 ms. Max.
Insulation Resistance	1,000 megohms min, at 500VDC, 50%RH
Dielectric Strength	3600 Vrms, 1 min. between coil and contacts 1200 Vrms, 1 min. between open contacts
Shock Resistance	10 g, 11ms, functional; 100 g, destructive
Vibration Resistance	DA 1.0 mm, 10 - 55 Hz
Power Consumption	.9 Watts
Ambient Temperature Range	-40 to 85 C, -40 to 130 C storage
Weight	31.5 grams approx.

### ORDERING INFORMATION

Example:	PC454	-1A	-12	P	F
Model					
Contact Form					
1A					
Coil Voltage					
Terminal Type					
Nil: QC + PC, P: All PC					
Insulation Material					
Nil: Class B, F: Class F (155 degrees C)					

**COIL DATA**

Coil Voltage	Resistance ohms $\pm 10\%$	Must Operate Voltage Max. (VDC)	Must Release Voltage Min. (VDC)	Continuous Voltage Max. (VDC)
5	27.7	3.75	0.5	5.5
6	40	4.5	0.6	6.6
9	90	6.75	0.9	9.9
12	160	9.0	1.2	13.2
24	640	18.0	2.4	26.4
48	2560	36.0	4.8	52.8
110	13440	82.5	11.0	121.0

Note: Custom coil voltages within the ranges shown are available on special order.

**Dimensions in Inches (millimeters)**

**Side View**

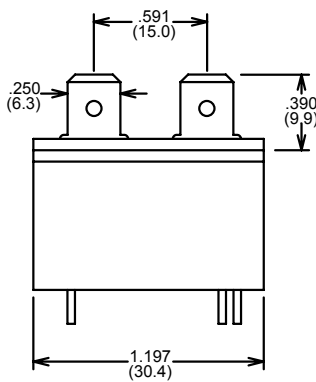

**End View**

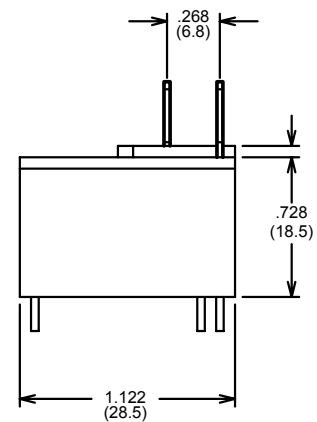

**Bottom View  
PC Board Layout**

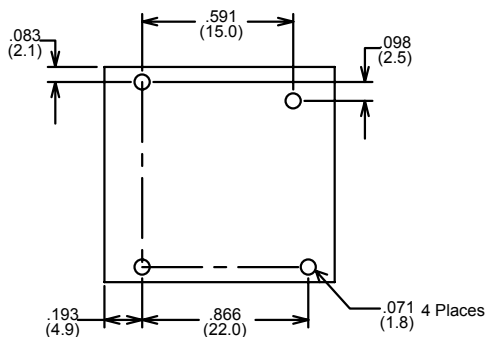

**Wiring Diagram**

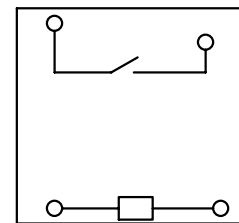

Tolerances  $\pm .010$  unless otherwise noted



3220 Commander Drive, Suite 102, Carrollton, Texas 75006

Sales: Call Toll Free (888) 997-3933 Fax (818) 342-5296 email: pickerwest@sbcglobal.net URL: pickercomponents.com