

IEC Appliance Inlet C14 with High Frequency Filter, X2Y Technology, ECO design, Front- or Rear Side Mounting

Standard- or Medical-Filter



Screw-on or rivet mounting
from front or rear side

Screw-on mounting from rear side
(integrated thread)

C14

70° C



Description

- Panel Mount:
Screw-on version from front or rear side
- 2 Functions:
Appliance Inlet, High frequency line filter as standard, industrial and medical version, Protection class I
- Quick connect terminals 6.3 x 0.8 mm

Approvals

- VDE License Number: 40023426
- UL License Number: E72928

Characteristics

- Very compact filter for frequencies up to 1 GHz
Patented X2Y Technologie for broadband high frequency filtering
- Double shielding for best filter performance
One single filter design for the given current range
- Designed for standard, industrial and medical applications
Suitable for assembly in metal plated plastic housings
- For use in equipment acc. IEC 60950/60601

Other versions on request

- Solder terminals

References

[General Product Information](#)

Weblinks

[Approvals](#), [RoHS](#), [CHINA-RoHS](#), [Mating Connectors](#), [e-Store](#), [Distributor-Stock-Check](#), [Accessories](#)

Technical Data

Ratings IEC	10A @ Ta 40 °C / 250VAC; 50Hz
Ratings UL/CSA	15A @ Ta 40 °C / 250VAC; 60Hz
Leakage Current	standard < 0.5 mA (250 V / 60Hz) medical < 43/80 µA (250 V / 60 Hz)
Dielectric Strength	> 1.7 kVDC between L-N > 2.7 kVDC between L/N-PE Test voltage (2 sec)
Allowable Operation Temp.	-25 °C to 85 °C
Climatic Category	25/085/21 acc. to IEC 60068-1
Degree of Protection	from front side IP 40 acc. to IEC 60529
Protection Class	Suitable for appliances with protection class 1 acc. to IEC 61140
Terminal	Quick connect terminals 6.3 x 0.8 mm
Panel Thickness s	Screw: max 8 mm Mounting screw torque max 0.5 Nm
Material: Housing	Thermoplast / steel tin-plated, black / metallic, UL 94V-0

Appliance-Inlet/-Outlet	C14 acc. to IEC/EN 60320-1, UL 498, CSA C22.2 no. 42 (for cold conditions) pin-temperature 70 °C, 10A, Protection Class 1
Line Filter	Standard, medical and industrial version, IEC 60939, IEC 60601-1, UL 1283, UL 544, CSA C22.2 no. 8 Technical details
MTBF	> 3'300'000h acc. to MIL-HB-217 F

Dimensions

54.5 mm
Front or rear side mounting for screws with nuts or blind rivets (panel cutout for frontside mounting)

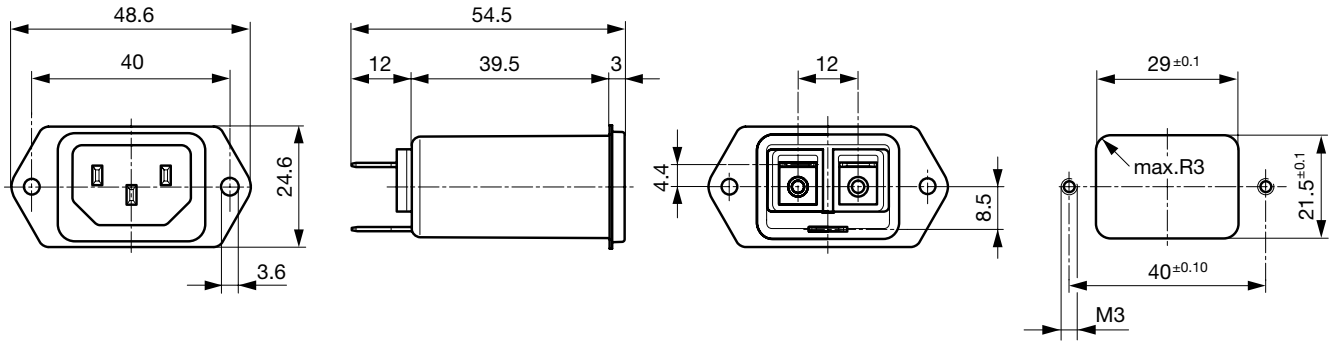

Rear side mounting with pre-formed, threaded holes for M3 screws (panel cutout for rear side mounting)

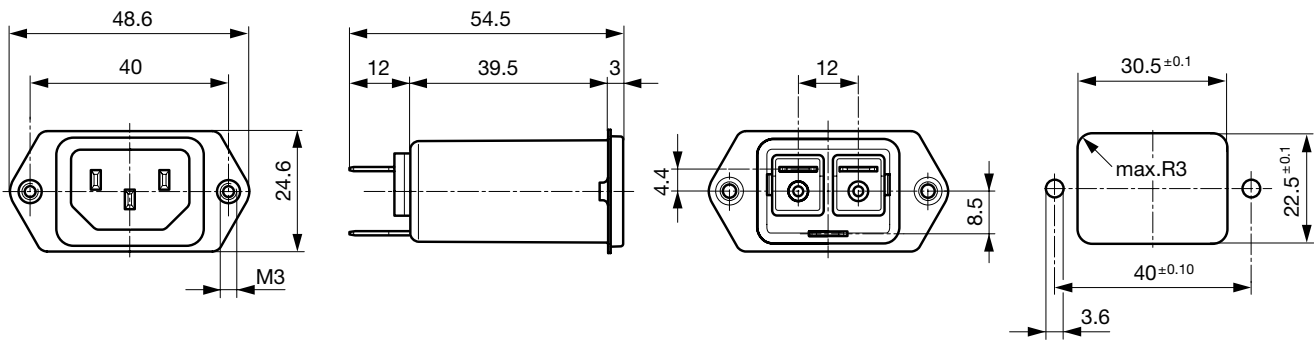

Technical Data of Filter-Components

Rated Current [A]	Filter-Type	Capacitance CX [nF]	Capacitance CY [nF]	R [MΩ]
10	Standard Version	1.25	2.5	-
10	Standard Version with Bleed Resistor	1.25	2.5	1
10	Industrial Version	2.35	4.7	-
10	Medical Version (M80)	0.225	0.45	1

Diagrams

Standard and industrial version

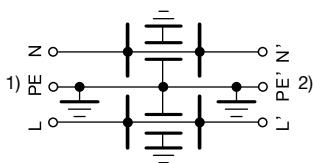

1) Line
2) Load

Medical M80 and standard version with bleed resistor

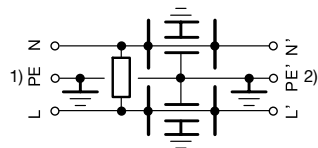

1) Line
2) Load

Attenuation Loss

- - - differential mode _____ common mode

Standard version
CISPR 17 Test Method

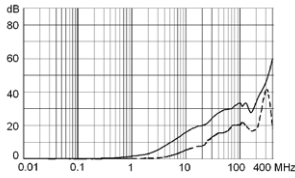

Alternate Test Method

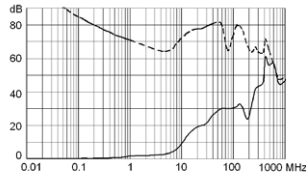

same attenuation loss with bleed resistor

Medical version (M80)
CISPR 17 Test Method

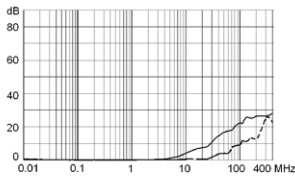

Alternate Test Method

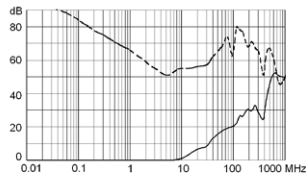

Industrial Version
CISPR 17 Test Method

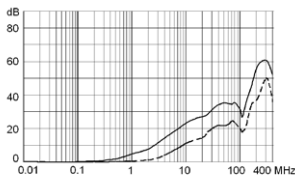

Alternate Test Method

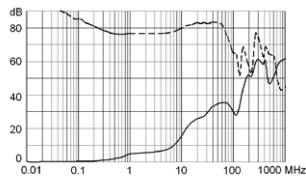

Comment about alternate test method
see table of variants

Variants

Rated Current IEC [A]	Rated Current UL [A]	Filter-Type	Panel mounting	Mounting side	Order Number
10	15	Standard Version	Screw-on/Rivet	Front-/Rear-Side	5150.0011.0
10	15	Standard Version	Screw	Rear-Side	5150.0011.1
10	15	Standard Version with Bleed Resistor	Screw-on/Rivet	Front-/Rear-Side	5150.0021.0
10	15	Standard Version with Bleed Resistor	Screw	Rear-Side	5150.0021.1
10	15	Industrial Version	Screw-on/Rivet	Front-/Rear-Side	5150.0041.0
10	15	Industrial Version	Screw	Rear-Side	5150.0041.1
10	15	Medical Version (M80)	Screw-on/Rivet	Front-/Rear-Side	5150.0031.0
10	15	Medical Version (M80)	Screw	Rear-Side	5150.0031.1

The Alternate Test Method allows the measurement in the GHz frequency range whereas the CISPR 17 method does not cover frequencies above 30MHz. The insertion loss is measured in a throughput method (common mode) and a cross coupled method (differential mode). The differential mode measurement of the alternate test method is not directly comparable to the conventional measurement acc. CISPR 17.

Further information on the X2Y filter technology and on the alternate insertion loss measurement method can be found under www.schurter.com/info_emc

Packaging unit 10 Pcs

Accessories

Description



Assorted Covers
Rear Cover

0859.0048



Cord retaining kits
Cord retaining strain relief

Flat head, E

4700.0005

Flat head, G

4700.0007

Mating Outlets/Connectors

Category / Description

Appliance Outlet Overview complete



IEC Appliance Outlet F, Screw-on Mounting, Front Side, Solder or Quick-connect Terminal

4787

IEC Appliance Outlet F, Snap-in Mounting, Front Side, Solder or Quick-connect Terminal

4788

IEC Appliance Outlet F or H, Screw-on Mounting, Front Side, Solder, PCB or Quick-connect Terminal

5091

IEC Appliance Outlet F or H, Screw-on Mounting, Front Side, Solder or Quick-connect Terminal

5092

[Appliance Outlet further types to 5150](#)

Connector Overview complete



IEC Connector C15, Rewireable, Straight

0101

IEC Connector C15A, Rewireable, Straight

0102

IEC Connector C15A, Rewireable, Straight

0102-G

IEC Connector C15A, Rewireable, Angled

0112

IEC Connector C13, Rewireable, Angled

4012

[Connector further types to 5150](#)

...

Power Cord Overview complete



Power Cord with IEC Connector C13, Angled

0311

Power Cord with IEC Connector C13, Angled

3011

Power Cord with IEC Connector C13, Angled

3012

Power Cord with IEC Connector C13, Angled

3013

Power Cord with IEC Connector C13

3020

[Power Cord further types to 5150](#)

...