

PATENT PENDING

PART NO.	"A" DIM	MATERIAL	TRAVEL
TCS-1	5.4[0.22]	RMS-01	3.0[0.12]
TCS-2		RMS-19	
TCS-3	4.2[0.16]	RMS-01	
TCS-4		RMS-19	

REV	MODIFICATION	DATE	DRN
1	PRODUCTION RELEASE	27/10/04	I.C
2	SCN 2004-206	02/12/04	I.C
3	SCN 2005-066	24/05/05	I.C
4	CO2010418	01/10/08	I.C
5	CO2010390	21/10/08	I.C
6	CO2010566	17/02/09	S.F

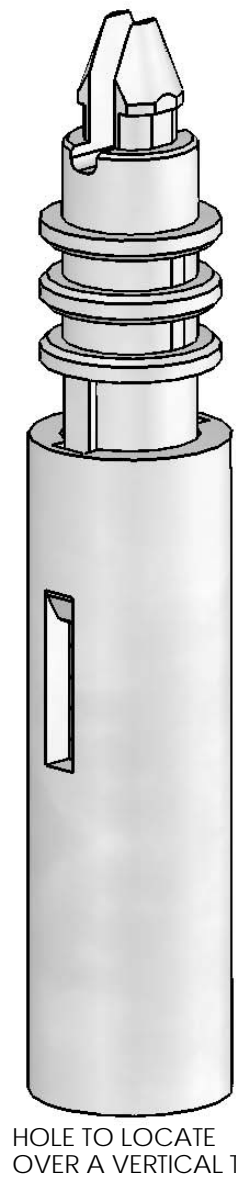
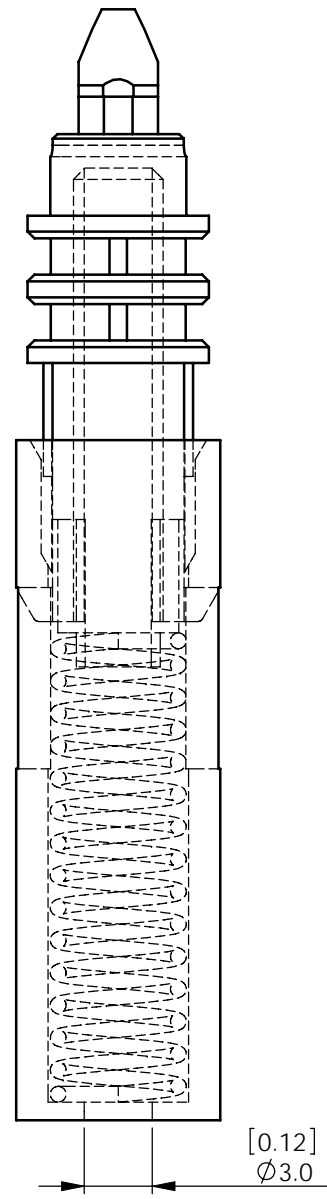
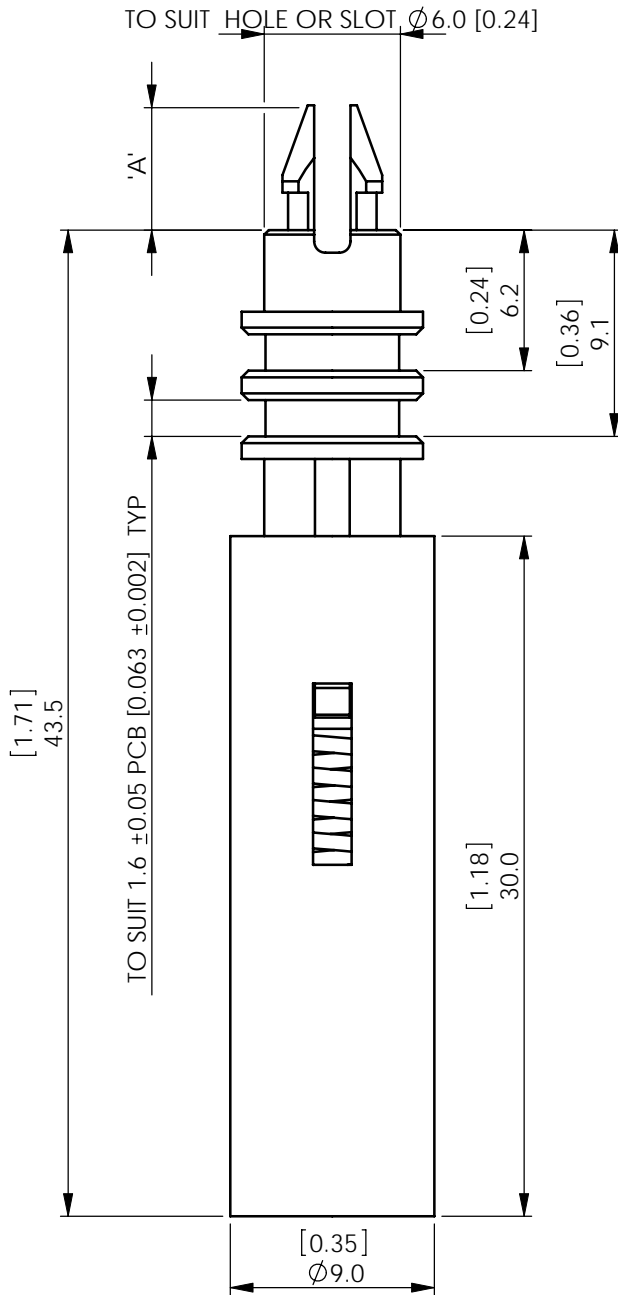

FIX TO SNAP-LOCK INTO :
 $\phi 4.2 \pm 0.05$ [0.165" ± 0.002] HOLE
 1.6 ± 0.05 [0.063" ± 0.002] PANEL THICKNESS

MATERIAL: NYLON 6/6 UL94 V-2 (RMS-01)
 OR NYLON 6/6 UL94 V-0 (RMS-19)
 SPRING: STAINLESS STEEL (RMS-230)

OTHER SPRING FORCES , MOUNTS
 & SPACER LENGTHS AVAILABLE
 BY SPECIAL ORDER.

ALTERNATE UNITS FOR REFERENCE ONLY

INFORMATION CONTAINED IN THIS DOCUMENT IS CONFIDENTIAL TO RICHCO INTERNATIONAL Co. Ltd. AND MAY NOT BE DISCLOSED OR REPRODUCED IN WHOLE OR PART WITHOUT THEIR WRITTEN CONSENT



METRIC GENERAL TOLERANCES ± 0.25
 ARE PRIMARY UNLESS OTHERWISE STATED
 1 DECIMAL PLACE ± 0.25
 2 DECIMAL PLACES ± 0.10
 ANGULAR $\pm 1^\circ$

IMPERIAL GENERAL TOLERANCES ± 0.010
 ARE FOR REFERENCE UNLESS OTHERWISE
 1 DECIMAL PLACE ± 0.01
 2 DECIMAL PLACES ± 0.005
 ANGULAR $\pm 1^\circ$

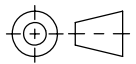
MATERIAL: SEE ABOVE		COLOUR: NATURAL	
TITLE: TOUCH CONTROL SPACER		PART No: TCS - X	
DRG No: 04-111	NPR REF: 2004-108	 SIZE A4	
DRN I.C	DATE 22/10/04		
SCALE 3:1		SHEET No 1 OF 1	