

4117



Open Type
13.2×15.3×18



Dust Covered
17.5×15×20

Features

- Superminiature, heavy power.
- Low coil power consumption.
- Switching current up to 20A.
- PC board mounting.
- Suitable for household appliances, electrical equipment, automation system, and automobile industry application.

Ordering Information

4117 C S 10 12VDC 1.0
1 2 3 4 5 6

1 Part number: 4117	4 Contact Current: 10:10A; 20:20A
2 Contact arrangement: A:1A;B:1B;C:1C;U:1U;V:1V;W:1W	5 Coil rated Voltage(V): DC:3,5,6,9,12,18,24
3 Enclosure: S: Sealed type; Z: Dust cover O: Open type	6 Coil power consumption: 1.0:1.0W; 1.2:1.2W

Contact Data

Contact Arrangement	1A(SPSTNO) 1B(SPSTNC) 1C (SPDT(B-M)) 1U(SPSTNODM) 1V(SPSTNCDB) 1W(SPDTNC-NO)	
Contact Material	AgNi AgSnO ₂	
Contact Rating (resistive)	1A,1B,1C: 10A/120VAC,28VDC 20A/14VDC ; 1U,1V,1W: 2×10A/120VAC,28VDC 2×20A/14VDC ;	
Max. Switching Power	1C: 280W 1200VA 1W: 2×280W 2×1200VA	
Max. Switching Voltage	75VDC 380VAC	Max. Switching Current:20A
Contact Resistance or Voltage drop	<50mΩ	Item 4.12 of IEC 61810-7
Operation life	Electrical	10 ⁶ Item 4.30 of IEC 61810-7
	Mechanical	10 ⁷ Item 4.31 of IEC 61810-7

Coil Parameter

Dash numbers	Coil voltage VDC		Coil resistance Ω ±10%	Pickup voltage VDC(max) (75% of rated voltage)	Release voltage VDC(min) (10% of rated voltage)	Coil power consumption W	Operate Time ms	Release Time ms
	Rated	Max.						
003-1000	3	3.9	9	2.25	0.3	1.0	≤10	<5
005-1000	5	6.5	25	3.75	0.5			
006-1000	6	7.8	36	4.50	0.6			
009-1000	9	11.7	85	6.75	0.9			
012-1000	12	15.6	145	9.00	1.2			
018-1000	18	23.4	324	13.5	1.8			
024-1000	24	31.2	576	18.0	2.4			
012-1200	12	15.6	120	9.00	1.2	1.2	<10	<5

CAUTION: 1.The use of any coil voltage less than the rated coil voltage will compromise the operation of the relay.
2.Pickup and release voltage are for test purposes only and are not to be used as design criteria.

Operation condition

Insulation Resistance	100MΩ min (at 500VDC)	Item 7 of IEC 61810-5
Dielectric Strength	50Hz 750V	Item 6 of IEC 61810-5
Between contacts	50Hz 1500V	Item 6 of IEC 61810-5
Between contact and coil		
Shock resistance	100m/s ² 11ms	IEC68-2-27 Test Ea
Vibration resistance	10~40Hz double amplitude 1.27mm	IEC68-2-6 Test Fc
Terminals strength	10N	IEC68-2-21 Test Ua1
Solderability	235℃ ± 2℃ 3 ± 0.5s	IEC68-2-20 Test Ta method 1
Ambient Temperature	-40~105℃	
Relative Humidity	85% (at 40℃)	IEC68-2-3Test Ca
Mass	9g (Open type) 12g	

Dimensions

mm /inch

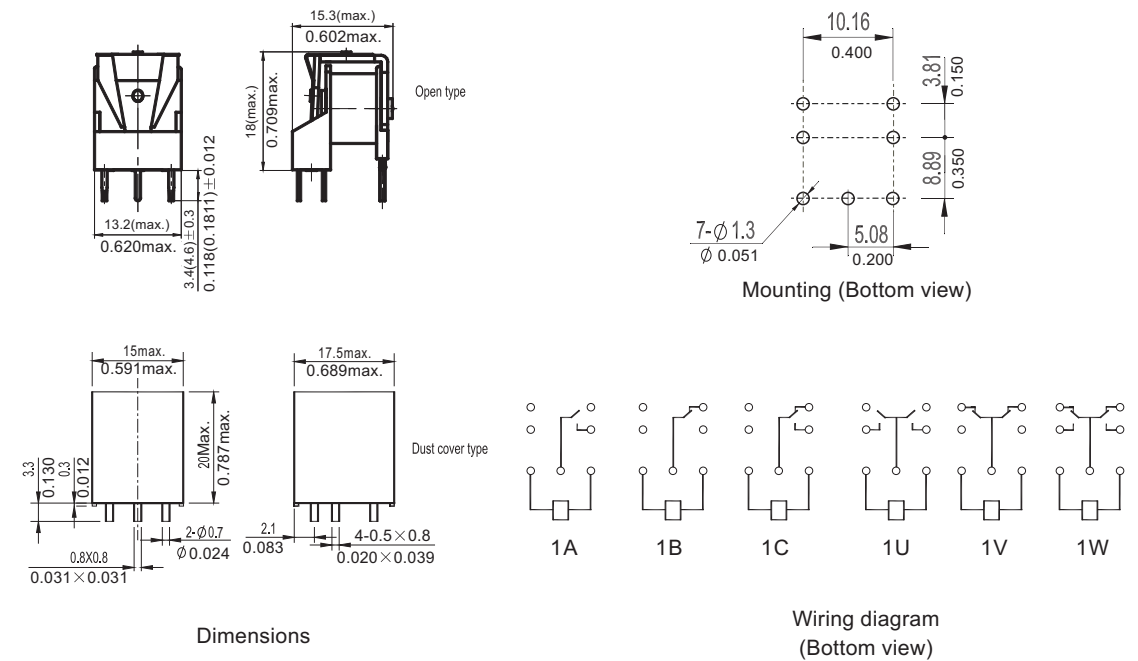

NOTES 1).Dimensions are in millimeters.
2).Inch equivalents are given for general information only.

Reference Data

