

## SOT-23 Plastic-Encapsulate Transistors

TRANSISTOR( NPN )

### Features

- Complementary to S9015

### Marking:

- J6

### Limiting Values (Absolute Maximum Rating)

Symbol	Parameter	Value	Unit
$V_{CB0}$	Collector-Base Voltage	50	V
$V_{CEO}$	Collector-Emitter Voltage	45	V
$V_{EBO}$	Emitter-Base Voltage	5	V
$I_C$	Collector Current	100	mA
$P_C$	Collector Power Dissipation	200	mW
$R_{\theta JA}$	Thermal Resistance From Junction To Ambient	625	°C/W
$T_j$	Junction Temperature	150	°C
$T_{stg}$	Storage Temperature	-55~+150	°C

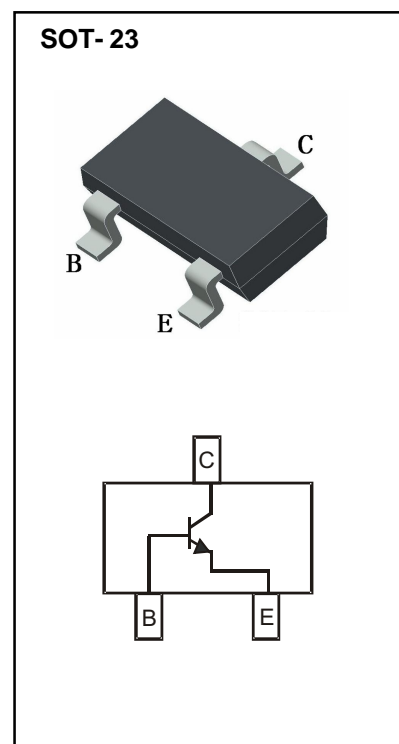

### Electrical Characteristics (Ta=25°C Unless otherwise specified)

Parameter	Symbol	Test conditions	Min	Typ	Max	Unit
Collector-base breakdown voltage	$V_{(BR)CBO}$	$I_C = 100\mu A, I_E = 0$	50			V
Collector-emitter breakdown voltage	$V_{(BR)CEO}$	$I_C = 0.1 mA, I_B = 0$	45			V
Emitter-base breakdown voltage	$V_{(BR)EBO}$	$I_E = 100\mu A, I_C = 0$	5			V
Collector cut-off current	$I_{CBO}$	$V_{CB} = 50 V, I_E = 0$			0.1	$\mu A$
Collector cut-off current	$I_{CEO}$	$V_{CE} = 35 V, I_B = 0$			1	$\mu A$
Emitter cut-off current	$I_{EBO}$	$V_{EB} = 3 V, I_C = 0$			0.1	$\mu A$
DC current gain	$h_{FE}$	$V_{CE} = 5 V, I_C = 1 mA$	200		1000	
Collector-emitter saturation voltage	$V_{CE(sat)}$	$I_C = 100 mA, I_B = 5 mA$			0.3	V
Base-emitter saturation voltage	$V_{BE(sat)}$	$I_C = 100 mA, I_B = 5 mA$			1	V
Transition frequency	$f_T$	$V_{CE} = 5 V, I_C = 10 mA$ $f = 30 MHz$	150			MHz

### CLASSIFICATION OF $h_{FE}$

Rank	L	H
Range	200-450	450-1000

# Typical Characteristics

Static Characteristic

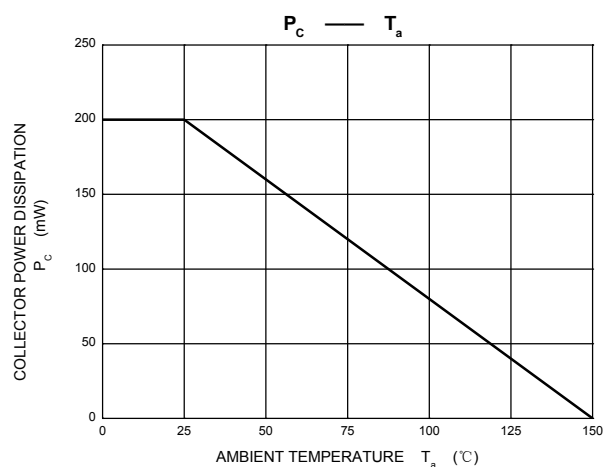
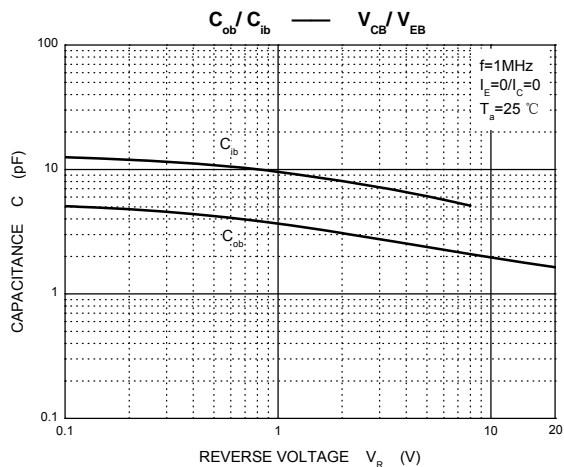
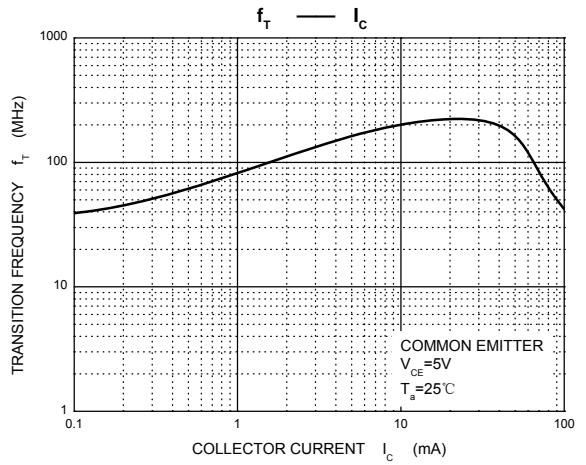
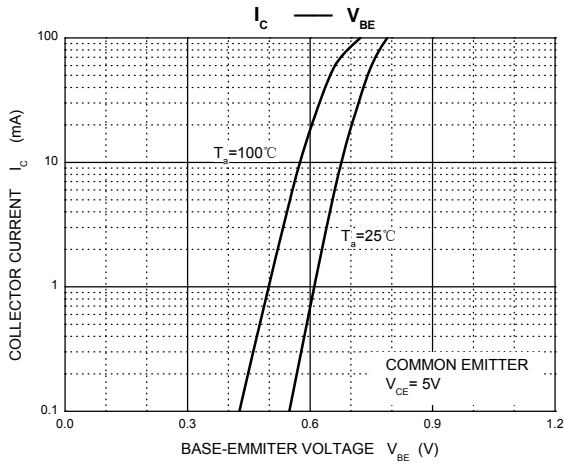
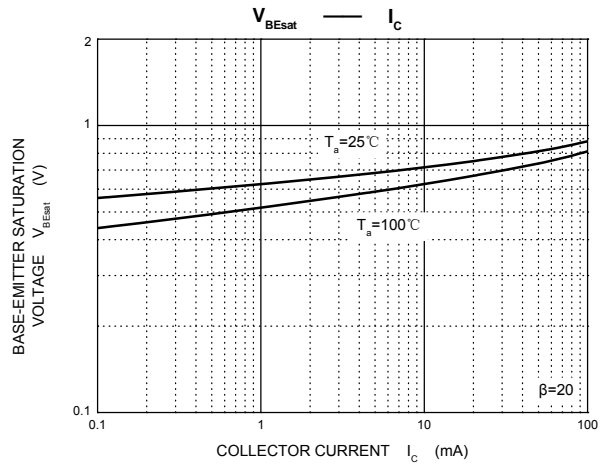
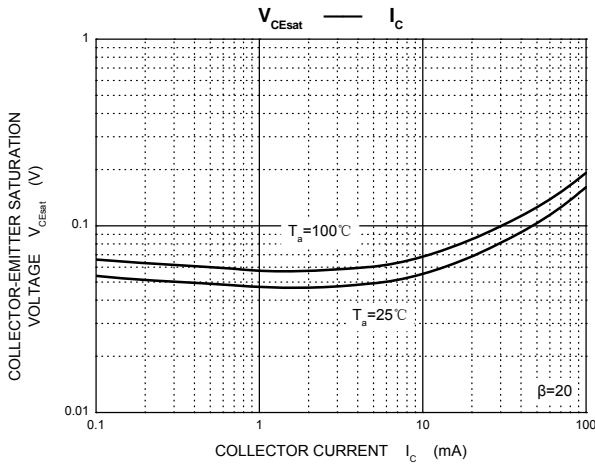
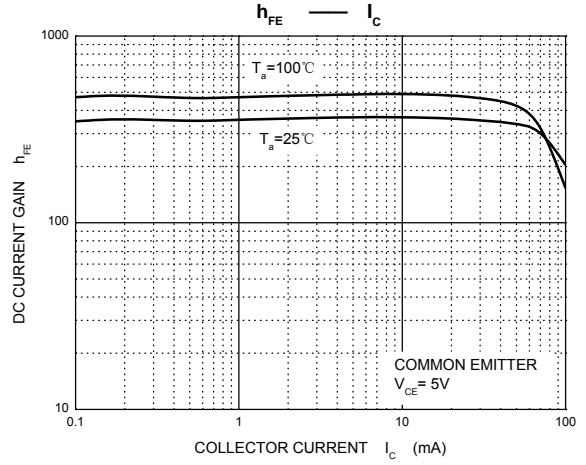
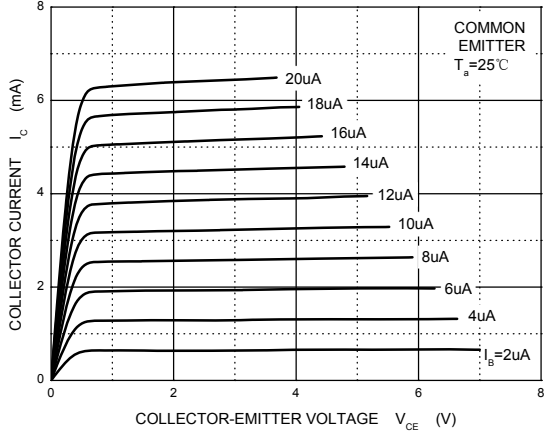

## SOT-23 Package Outline Dimensions

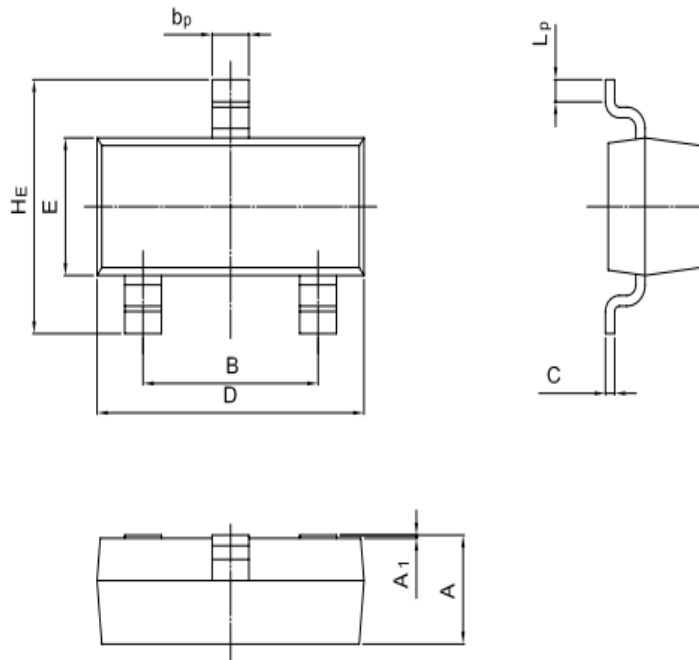

UNIT	A	B	bp	C	D	E	HE	A1	Lp
mm	1.40 0.95	2.04 1.78	0.50 0.35	0.19 0.08	3.10 2.70	1.65 1.20	3.00 2.20	0.100 0.013	0.50 0.20

## SOT-23 Suggested Pad Layout

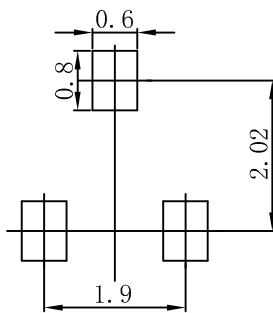

### Note:

1. Controlling dimension: in millimeters.
2. General tolerance:  $\pm 0.05$  mm.
3. The pad layout is for reference purposes only.

### NOTICE

JSJD reserve the right to make modifications, enhancements, improvements, corrections or other changes without further notice to any product herein. JSJD does not assume any liability arising out of the application or use of any product described herein.

# Reel Taping Specifications For Surface Mount Devices-SOT-23

## SOT-23 Embossed Carrier Tape

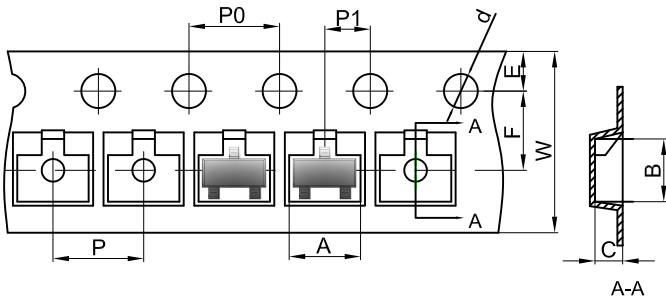

### Packaging Description:

SOT-23 parts are shipped in tape. The carrier tape is made from a dissipative (carbon filled) polycarbonate resin. The cover tape is a multilayer film (Heat Activated Adhesive in nature) primarily composed of polyester film, adhesive layer, sealant, and anti-static sprayed agent. These reeled parts in standard option are shipped with 3,000 units per 7" or 17.8cm diameter reel. The reels are clear in color and is made of polystyrene plastic (anti-static coated).

Dimensions are in millimeter

Pkg type	A	B	C	d	E	F	P0	P	P1	W
SOT-23	3.15	2.77	1.22	Ø1.50	1.75	3.50	4.00	4.00	2.00	8.00

## SOT-23 Tape Leader and Trailer

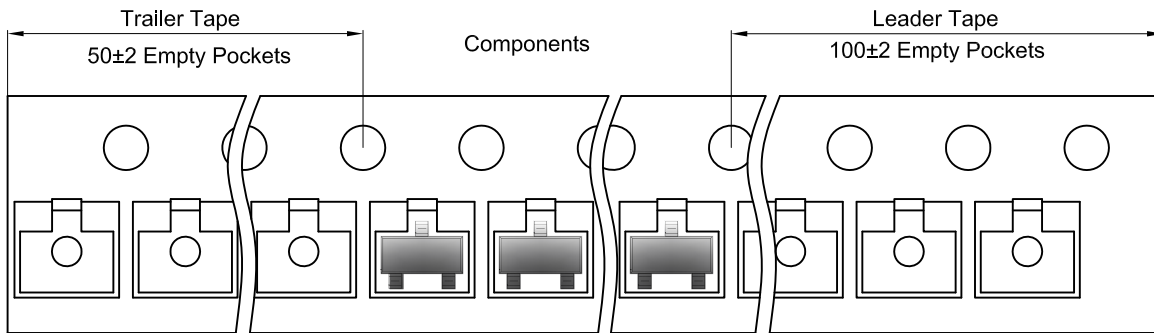

## SOT-23 Reel

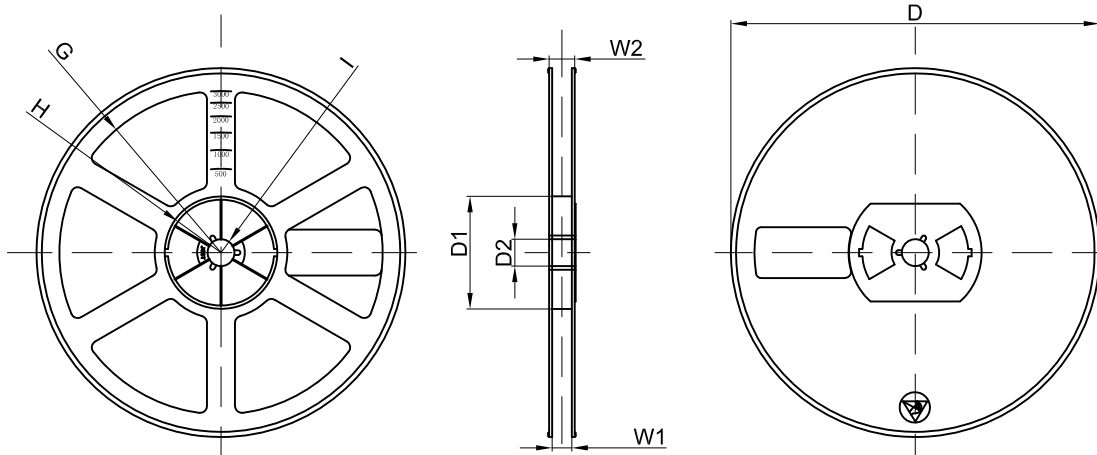

Dimensions are in millimeter

Reel Option	D	D1	D2	G	H	I	W1	W2
7" Dia	Ø178.00	54.40	13.00	R78.00	R25.60	R6.50	9.50	12.30

REEL	Reel Size	Box	Box Size(mm)	Carton	Carton Size(mm)	G.W.(kg)
3000 pcs	7 inch	45,000 pcs	203×203×195	180,000 pcs	438×438×230	