

| | |
|-----|-------------|
| B12 | GND |
| B9 | VBUS |
| B5 | CC2 |
| A5 | CC1 |
| A9 | VBUS |
| A12 | GND |
| PIN | SIGNAL NAME |

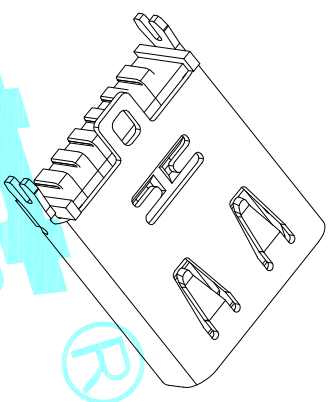
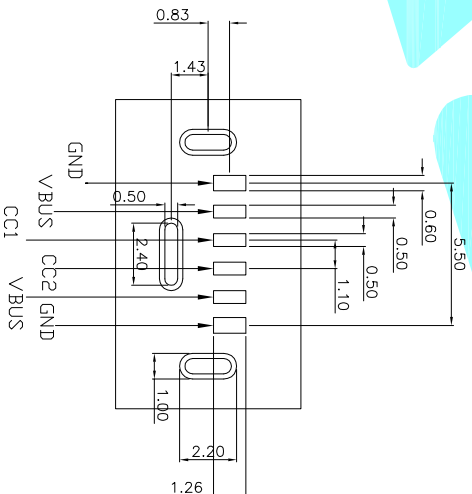
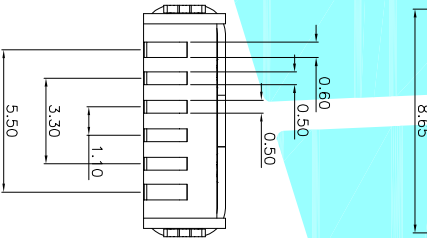
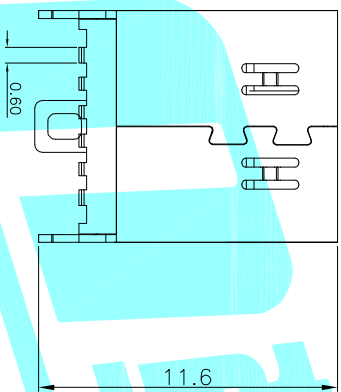
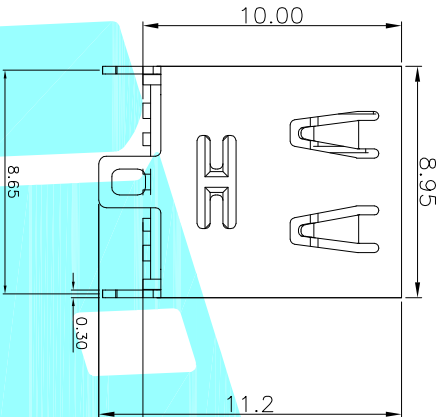
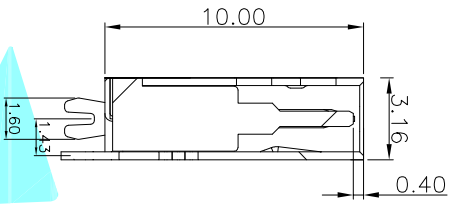

NOTES:

- 1.MATERIAL:**
MOLDING: LCP UL94 V-0
CONTACT: COPPER ALLOY.
GOLD PLATED MIN ON CONTACT AREA, 100u"
Min TIN (LEAD FREE) ON SOLDER AREA,
SHELL: SUS304-H,T=0.30±0.03mm
50u" NICKEL PLATING OVER ALL.
- 2.MECHANICAL:**
INSERTION: 5~20N.
EXTRACTION: 8~20N AFTER TEST.
DURABILITY: 10000 CYCLES
- 3.ELECTRICAL:**
CURRENT: 5A FOR VBUS;
1.25A FOR GND PIN.
0.25A FOR OTHER.
VOLTAGE: 20 V MAX
WITHSTANDING VOLTAGE: 100V AC R.M.S.
CONTACT RESISTANCE: 40mΩ MAX.
INSULATION RESISTANCE: 100MΩ MIN.

| | | | | | |
|------|-----------|---------|------|-----------------|-----------|
| ③ | Shell | — | 1 | STAINLESS STEEL | Ni Plated |
| ② | Contact | — | 6 | COPPER ALLOY | Au Plated |
| ① | Housing | — | 1 | LCP | Black |
| ITEM | PART NAME | TER'NO. | QTY. | MATERIAL | FINISHING |

| | | | |
|-----------|------------|------------|---------------------|
| APPROVALS | DATE | TITLE: | USB CONNECTOR |
| DRAWN | JIANKUN LU | 2020.07.01 | ELECTRONICS CO.,LTD |

| | | | |
|----------------|---------------|----------|----------------|
| CHECKED | | | |
| APPROVALS | | PART NO. | TYPE-C-31-D-02 |
| TOLERANCES ARE | 30~0.1L ±0.30 | ANGLE | SCALE: 1:1 |
| | 10~30 ±0.25 | | PROJ: |
| | 5~10 ±0.20 | | SHEET 1 OF 1 |
| | ~5 ±0.15 | | |

| | | | | | | |
|---------|------|-------|--------------|---------|--------|--------|
| ECN NO. | REV. | DATE. | DESCRIPTION. | CHANGE. | CHECK. | APPRO. |
| | A | | NEW | | | |