

DWG. NO.		260-510-0850G	
REV	DESCRIPTION	BY DATE	APPRO
B	REVISED CONTACT PER ECR 8576	JKM 08/19/05	DCM

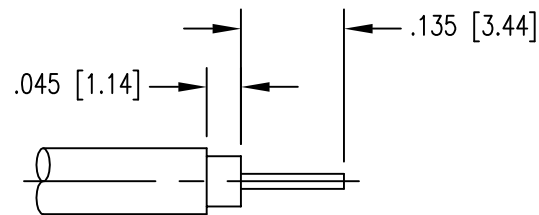
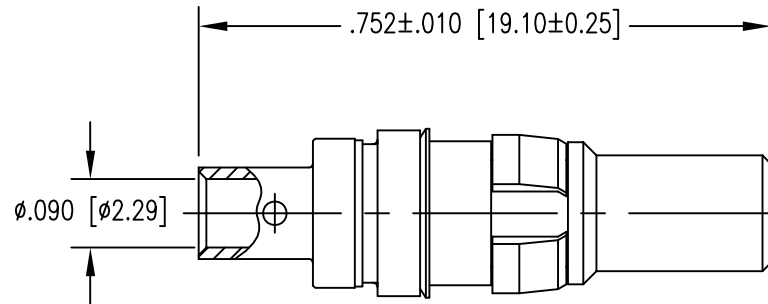
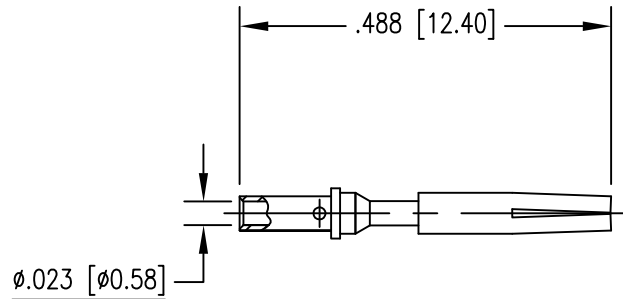

CABLE TRIMMING DIMENSIONS

NOTES:

- MATERIALS:
 BODY: BRASS PER ASTM B16
 CONTACT: COPPER ALLOY
 INSULATOR: TEFLON PER ASTM D1710
 CLIP RING: BERYLLIUM COPPER PER ASTM B194
 SPRING WASHER: PHOSPHOR BRONZE PER ASTM B103
- FINISH:
 CLIP RING: .000100 MIN. NICKEL PER QQ-N-290 OVER COPPER FLASH
 SPRING WASHER: .000050 MIN. GOLD PER MIL-G-45204 OVER .000050 MIN. NICKEL PER QQ-N-290
 ALL OTHER METAL PARTS: .000030 MIN. GOLD PER MIL-G-45204 OVER .000050 MIN. NICKEL PER QQ-N-290
- FOR USE WITH .085 SEMI-RIGID CABLE OR EQUIVALENT.
- FOR CABLING PROCEDURES USE CAP 5-15 WITH TRIMMING DIMENSIONS SHOWN.

PER ASME Y14.5M-1994 UNLESS OTHERWISE SPECIFIED: DIMENSIONS ARE IN INCHES [MM]		NORTROP GRUMMAN	
TOLERANCES: DECIMALS .XX ± .01 [0.254] XXX ± .005 [0.127] ANGLES ± 2°		Winchester Electronics 400 Park Road Watertown, CT 06795	
SCALE: 4:1		TITLE	
CUSTOMER DRAWING		RDM 50 OHM PLUG	
DRAWN JWH	DATE 8/13/02	CHECKED JED	DATE 8/26/02
APPROVED JEM	DATE 8/22/02	APPROVED KJT	DATE 8/26/02
A		260-510-0850G	SHT. OF REV. 1 1 B