

Super-mini Signal Conditioners Mini-M Series

DC ALARM

(thumbwheel switch adjustment; single SPDT output)

Functions & Features

- Provides a SPDT relay output at a preset DC input level
- Thumbwheel switch setpoint adjustments
- Adjustable deadband
- Latching or non-latching output
- Relays energized or de-energized at tripped condition

Typical Applications

- Annunciator
- Various alarm applications

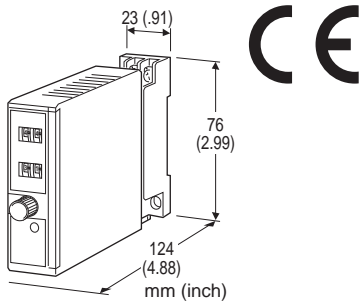

MODEL: M2AS1-[1][2][3][4]-[5][6]

ORDERING INFORMATION

- Code number: M2AS1-[1][2][3][4]-[5][6]
- Specify a code from below for each of [1] through [6].
(e.g. M2AS1-6111-M2/CE/Q)
- Specify the specification for option code /Q
(e.g. /C01/S01)

[1] INPUT

Current

A: 4 - 20 mA DC (Input resistance 250 Ω)

Voltage

4: 0 - 10 V DC (Input resistance 1 MΩ min.)

5: 0 - 5 V DC (Input resistance 1 MΩ min.)

6: 1 - 5 V DC (Input resistance 1 MΩ min.)

[2] ALARM OUTPUT

1: Hi (coil energized at alarm)

2: Hi (coil de-energized at alarm)

3: Lo (coil energized at alarm)

4: Lo (coil de-energized at alarm)

[3] ON DELAY TIME

1: 0.05 second

2: 0.1 second

3: 0.2 second

4: 0.5 second

5: 1 second

6: 2 seconds

7: 5 seconds

8: 10 seconds

[4] POWER ON DELAY TIME

1: 1 second

2: 2 seconds

3: 3 seconds

4: 4 seconds

[5] POWER INPUT

AC Power

M2: 100 - 240 V AC (Operational voltage range 85 - 264 V, 47 - 66 Hz)

DC Power

R: 24 V DC

(Operational voltage range 24 V ±10 %, ripple 10 %p-p max.)

R2: 11 - 27 V DC

(Operational voltage range 11 - 27 V, ripple 10 %p-p max.)

(Select 'N' for 'Standards & Approvals' code.)

P: 110 V DC

(Operational voltage range 85 - 150 V, ripple 10 %p-p max.)

[6] OPTIONS (multiple selections)

Standards & Approvals (must be specified)

/N: Without CE

/CE: CE marking

Other Options

blank: none

/Q: Option other than the above (specify the specification)

SPECIFICATIONS OF OPTION: Q (multiple selections)

COATING (For the detail, refer to M-System's web site.)

/C01: Silicone coating

/C02: Polyurethane coating

/C03: Rubber coating

TERMINAL SCREW MATERIAL

/S01: Stainless steel

GENERAL SPECIFICATIONS

Construction: Plug-in

Connection: M3 screw terminals (torque 0.8 N·m)

Screw terminal: Chromated steel (standard) or stainless steel

Housing material: Flame-resistant resin (black)

Isolation: Input to output to power

Overrange input: -14 to +113.5 %

When the relay's untripped point relative to the preset alarm setpoint and deadband is out of this range, the relay remains latched.

Setpoint adjustments: Thumbwheel switches (front);

0 - 99 % independently; 1 % increments

Deadband (hysteresis) : Thumbwheel switches (front);

1 - 99 % independently; 1 % increments

(latching output when set to 00)

Front LED: Red light turns on when the coil is energized.

Reset input: Latched output reset with the front control button or remotely via base socket terminals.

INPUT SPECIFICATIONS

■ DC Current:

Shunt resistor attached to the input terminals (0.5 W)

■ Reset Contact Input

ON resistance: $\leq 1 \text{ k}\Omega$

Detecting level: $\leq 0.43 \text{ V}$

OFF resistance: $\geq 50 \text{ k}\Omega$

Detecting level: $\geq 4 \text{ V}$

OUTPUT SPECIFICATIONS

■ Relay Contact:

120 V AC @5 A ($\cos \phi = 1$)

240 V AC @2.5 A ($\cos \phi = 1$)

30 V DC @5 A (resistive load)

Maximum switching voltage: 250 V AC or 120 V DC

Maximum switching power: 600 VA or 150 W

Minimum load: 5 V DC @10 mA

Mechanical life: 5×10^7 cycles

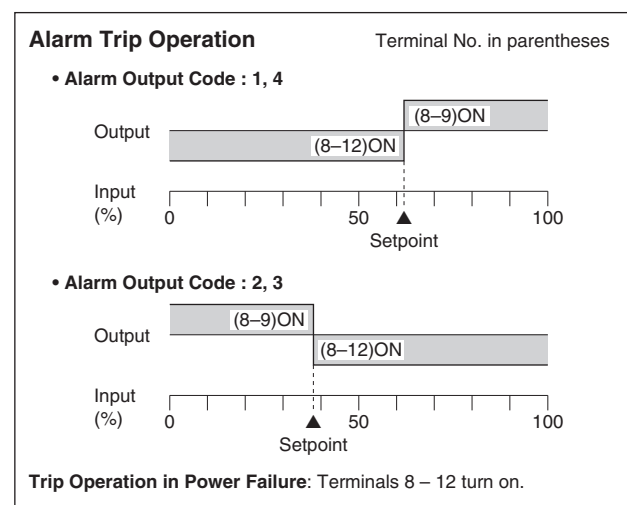

INSTALLATION

Power Consumption

•AC:

Approx. 3 VA at 100 V

Approx. 4 VA at 200 V

Approx. 5 VA at 264 V

•DC: Approx. 3 W

Operating temperature: -5 to +55°C (23 to 131°F)

Operating humidity: 30 to 90 %RH (non-condensing)

Mounting: Surface or DIN rail

Installation Base (model: M2BS) is not adaptable.

Weight: 150 g (0.33 lb)

PERFORMANCE in percentage of span

Setpoint accuracy: $\pm 0.5 \%$

Deadband setpoint accuracy: $\pm 0.5 \%$

Power ON timer: Rating $\pm 0.5 \text{ sec.}$ or 20 %, whichever is greater.

Trip point repeatability: $\pm 0.05 \%$

Temp. coefficient: $\pm 0.015 \%/^{\circ}\text{C}$ ($\pm 0.008 \%/^{\circ}\text{F}$)

Delay time (response time with 90 % setpoint for a step input 0 - 100 %)

Codes 1, 2: Rating $\pm 25 \text{ msec.}$

Codes 3 to 8: Rating $\pm 20 \%$

Line voltage effect: $\pm 0.1 \%$ over voltage range

Insulation resistance: $\geq 100 \text{ M}\Omega$ with 500 V DC

Dielectric strength: 2000 V AC @1 minute (input to output to power to ground)

STANDARDS & APPROVALS

EU conformity:

EMC Directive

EMI EN 61000-6-4

EMS EN 61000-6-2

Low Voltage Directive

EN 61010-1

Measurement Category II (output)

Installation Category II (power)

Pollution Degree 2

Input or output to power: Reinforced insulation (300 V)

Input to output: Basic insulation (300 V)

RoHS Directive

EN 50581

EXTERNAL VIEW

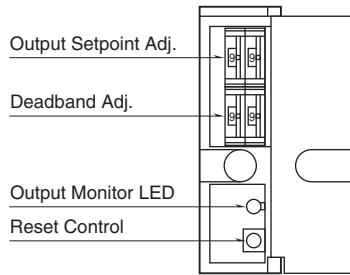

EXTERNAL DIMENSIONS unit: mm (inch)

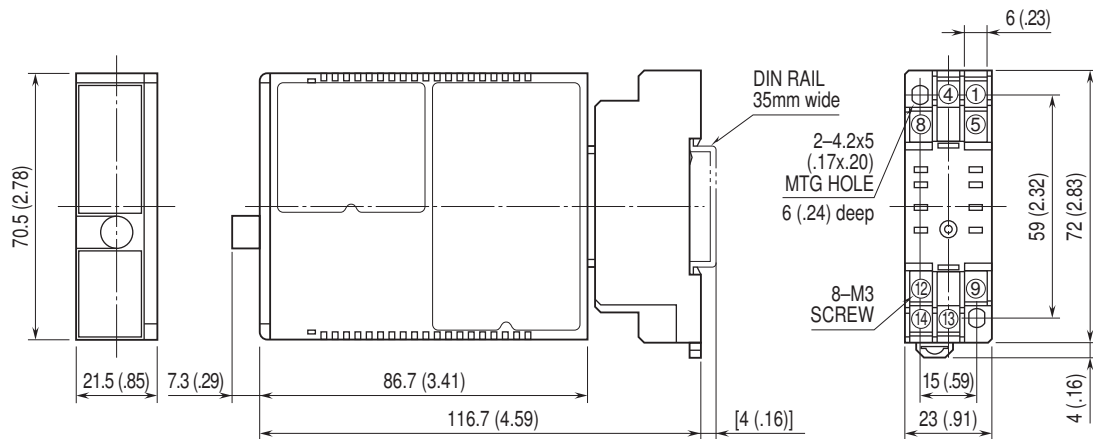

• When mounting, no extra space is needed between units.

TERMINAL ASSIGNMENTS unit: mm (inch)

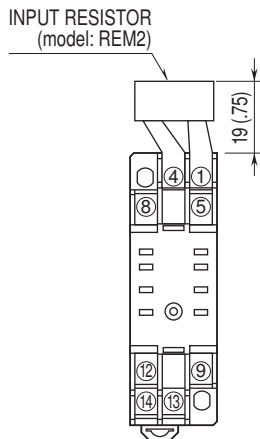

Input shunt resistor attached for current input.

SCHEMATIC CIRCUITRY & CONNECTION DIAGRAM

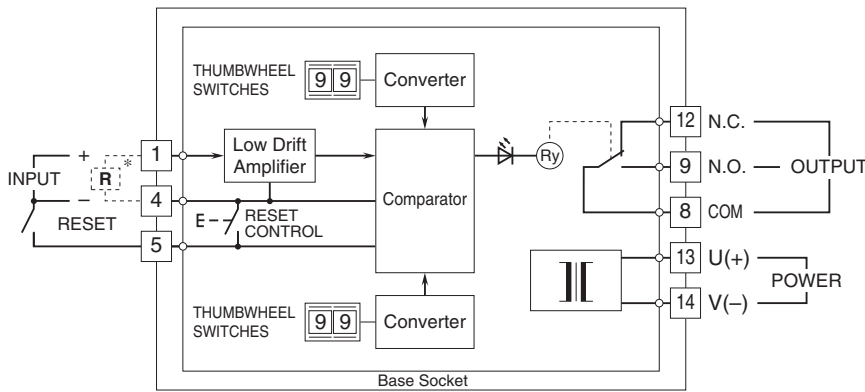

Relay Protection • AC Powered

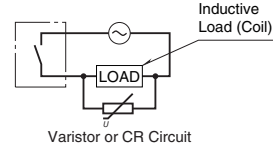

• DC Powered

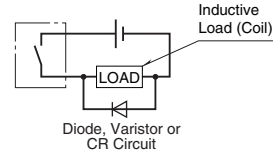

FUNCTIONS

■ **HIGH ALARM:** When the signal input exceeds the preset setpoint, the relay provides a tripped condition.

• Hi Alarm

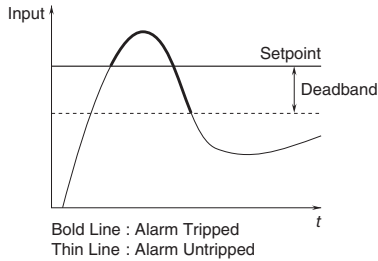

■ **POWER ON DELAY TIME:** The relay does not provide a tripped condition for a duration of the preset Power ON Delay Time (TDP) after the power supply is turned on, even when the signal input is in an alarm range.

• Power ON Delay Time (TDP) with Hi Alarm

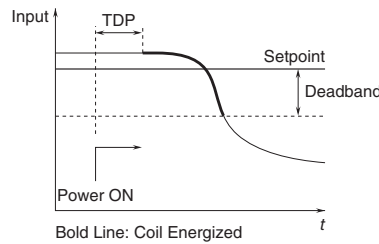

■ **LOW ALARM:** When the signal input goes below the preset setpoint, the relay provides a tripped condition

• Lo Alarm

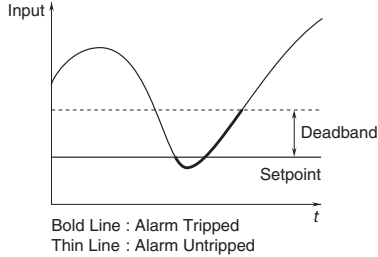

■ **LATCHING OUTPUT:** The relay does not return to an untripped condition once the signal input goes across the threshold, unless:

- (1) the Reset control button is pressed,
- (2) the Reset input terminal is closed, or
- (3) the power supply is removed.

• Latching Output with Hi Alarm

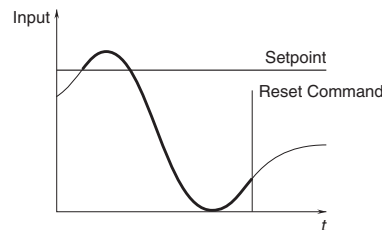

■ **ON DELAY TIME:** The relay status does not change until after the preset ON Delay Time (TD) once the signal input goes across the threshold.

• ON Delay Time (TD) with Hi Alarm

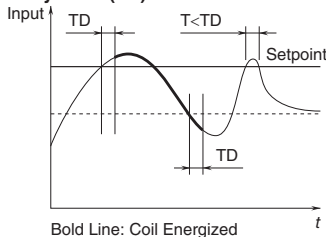



Specifications are subject to change without notice.