

Features

- Baseline JPEG Compression/Decompression
- MPEG-1 Encode/Decode at 24 fps QVGA
- Compatible with Various Types of Display Devices
- Video Encoder Including Line Driver for NTSC/PAL TV Signal
- Digital Outputs Include Composite, 16-bit YC, RGB 565
- SDRAM Interface – Supports from 16M Bits to 256M Bits
- Unified Memory Architecture (All Program and Data Stored in SDRAM)
- Support for Most Flash Card Interfaces (MMC, SD, SSFDC, Memory Stick™, CompactFlash®)
- USB 1.1 Host/Slave Controller and USART Interfaces
- Up to Nine External Interrupts and Wake-up Pin
- Serial Peripheral Interface for Loading Boot Code and Controlling System
- Two DACs for Audio Output
- Audio Data Interface for Connection to External Stereo ADC/DAC
- Three General-Purpose Timers for Waveform Generation (PWM, etc.) and Event Monitoring
- Up to 2M Bytes Program Space
- Support for RTOS
- All Low-level Software, Application Samples are Provided
- 208-ball BGA Package
- 1.8-volt Core and 3.3 V I/O Operation

Figure 1. Typical DSC Application Using AT76C113P

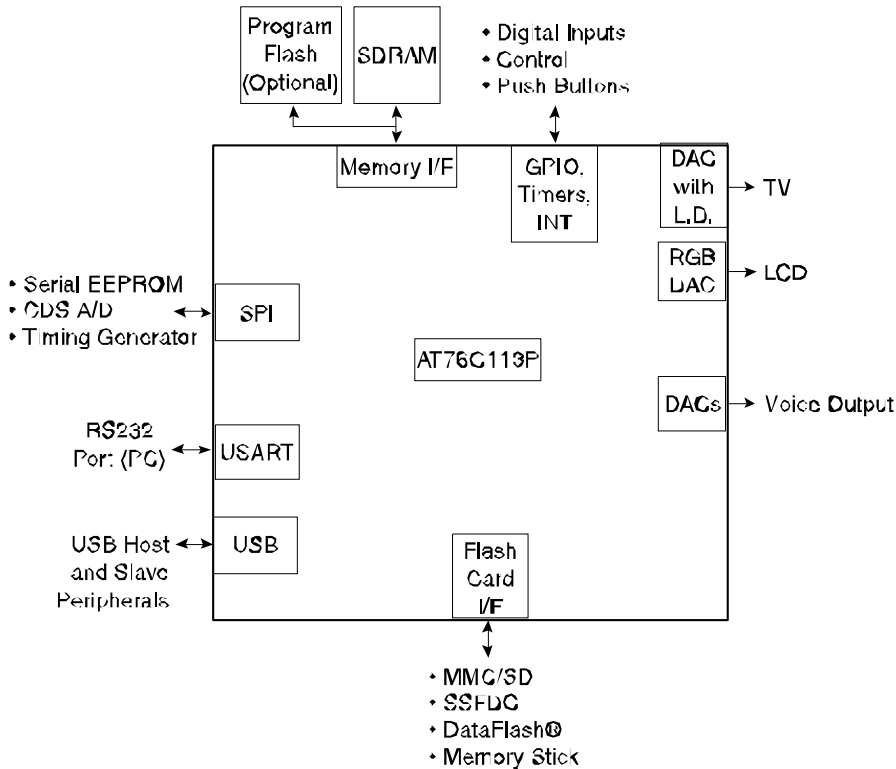

High-Performance Digital Media Processor

AT76C113P Summary

5657AS-IMAGE-01/04



Note: This is a summary datasheet. A complete document is available under NDA. For more information, please contact your local Atmel Sales Office.



Description

The AT76C113P is a highly integrated media processor. It combines a number of required functions listed below:

- Image/Video/Audio decoding
- Image display
- Image processing and image storing
- Control of general-purpose I/O functions
- Data communication
- Control of user functions
- On-screen Display

The device is based on an ARM[®] microprocessor that controls the entire chip. A number of hardware resources, controlled by ARM, perform media functions such as image processing, JPEG coding/decoding, MPEG-1 decoding, DMA access to SDRAM, and video encoding. All these computationally-intensive functions are implemented in hardware which can be programmed according to user specifications, thus allowing ARM to be free for other user-defined functions.

Part Versions

The AT76C113P device comes in two versions, each with slightly different features. These features are summarized in Table 1.

Table 1. AT76C113 Part Versions

Part Number	Maximum Imager Resolution (Pixels)	Maximum SDRAM Size (Mbytes)	USB Functionality
AT76C113-P	> 2M	512	Slave Only
AT76C113-PU	> 2M	512	Slave and Host



Atmel Corporation

2325 Orchard Parkway
San Jose, CA 95131, USA
Tel: 1(408) 441-0311
Fax: 1(408) 487-2600

Regional Headquarters

Europe

Atmel Sarl
Route des Arsenaux 41
Case Postale 80
CH-1705 Fribourg
Switzerland
Tel: (41) 26-426-5555
Fax: (41) 26-426-5500

Asia

Room 1219
Chinachem Golden Plaza
77 Mody Road Tsimshatsui
East Kowloon
Hong Kong
Tel: (852) 2721-9778
Fax: (852) 2722-1369

Japan

9F, Tonetsu Shinkawa Bldg.
1-24-8 Shinkawa
Chuo-ku, Tokyo 104-0033
Japan
Tel: (81) 3-3523-3551
Fax: (81) 3-3523-7581

Atmel Operations

Memory

2325 Orchard Parkway
San Jose, CA 95131, USA
Tel: 1(408) 441-0311
Fax: 1(408) 436-4314

Microcontrollers

2325 Orchard Parkway
San Jose, CA 95131, USA
Tel: 1(408) 441-0311
Fax: 1(408) 436-4314

La Chantrerie
BP 70602
44306 Nantes Cedex 3, France
Tel: (33) 2-40-18-18-18
Fax: (33) 2-40-18-19-60

ASIC/ASSP/Smart Cards

Zone Industrielle
13106 Rousset Cedex, France
Tel: (33) 4-42-53-60-00
Fax: (33) 4-42-53-60-01

1150 East Cheyenne Mtn. Blvd.
Colorado Springs, CO 80906, USA
Tel: 1(719) 576-3300
Fax: 1(719) 540-1759

Scottish Enterprise Technology Park
Maxwell Building
East Kilbride G75 0QR, Scotland
Tel: (44) 1355-803-000
Fax: (44) 1355-242-743

RF/Automotive

Theresienstrasse 2
Postfach 3535
74025 Heilbronn, Germany
Tel: (49) 71-31-67-0
Fax: (49) 71-31-67-2340

1150 East Cheyenne Mtn. Blvd.
Colorado Springs, CO 80906, USA
Tel: 1(719) 576-3300
Fax: 1(719) 540-1759

Biometrics/Imaging/Hi-Rel MPU/ High Speed Converters/RF Datacom

Avenue de Rochepleine
BP 123
38521 Saint-Egreve Cedex, France
Tel: (33) 4-76-58-30-00
Fax: (33) 4-76-58-34-80

Literature Requests

www.atmel.com/literature

Disclaimer: Atmel Corporation makes no warranty for the use of its products, other than those expressly contained in the Company's standard warranty which is detailed in Atmel's Terms and Conditions located on the Company's web site. The Company assumes no responsibility for any errors which may appear in this document, reserves the right to change devices or specifications detailed herein at any time without notice, and does not make any commitment to update the information contained herein. No licenses to patents or other intellectual property of Atmel are granted by the Company in connection with the sale of Atmel products, expressly or by implication. Atmel's products are not authorized for use as critical components in life support devices or systems.

© Atmel Corporation 2004. All rights reserved. Atmel® and combinations thereof and DataFlash® are the registered trademarks of Atmel Corporation or its subsidiaries. ARM® is a registered trademark of ARM, Ltd. Memory Stick™ is a trademark of Sony Electronics Inc. CompactFlash® is a registered trademark of Sandisk Corporation.

Other terms and product names may be the trademarks of others.



Printed on recycled paper.