**FEATURES**

- 100 mm² Square Active Area
- Responsivity @ 3 nm 0.16 A/W
- Detection Range 1 nm to 12 nm
- Shipped with Protective Cover

ELECTRO-OPTICAL CHARACTERISTICS AT 25°C

PARAMETERS	TEST CONDITIONS	MIN	TYP	MAX	UNITS
Active Area	10 mm x 10 mm		100		mm ²
Responsivity, \mathcal{R}	@3 nm		0.16		A/W
Shunt Resistance, Rsh	@ ± 10 mV	20			Ohms
Reverse Breakdown Voltage, V_R	$I_R = 1 \mu\text{A}$	5	10		Volts
Capacitance, C	$V_R = 0$ V		10	44	nF

THERMAL PARAMETERS

STORAGE AND OPERATION TEMPERATURE RANGE	
Ambient	-10° to 40°C
Nitrogen or Vacuum	-20°C to 80°C
Maximum Junction Temperature	70°C
Lead Soldering Temperature ¹	260°C

¹0.08" from case for 10 seconds.

TYPICAL RESPONSIVITY at 25° C

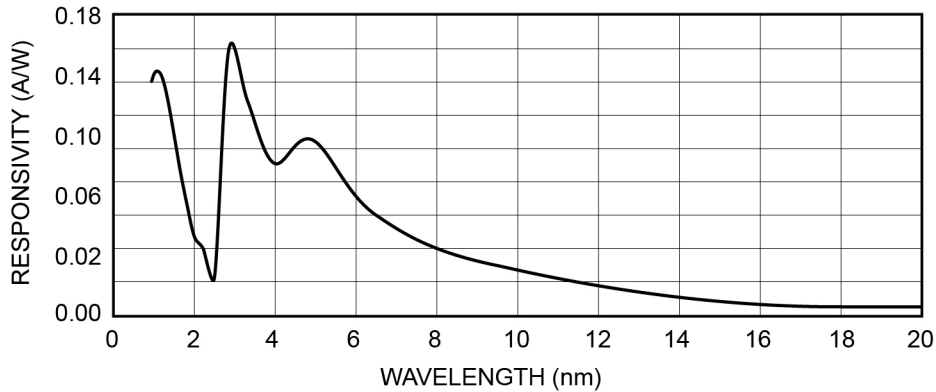

PACKAGE INFORMATION

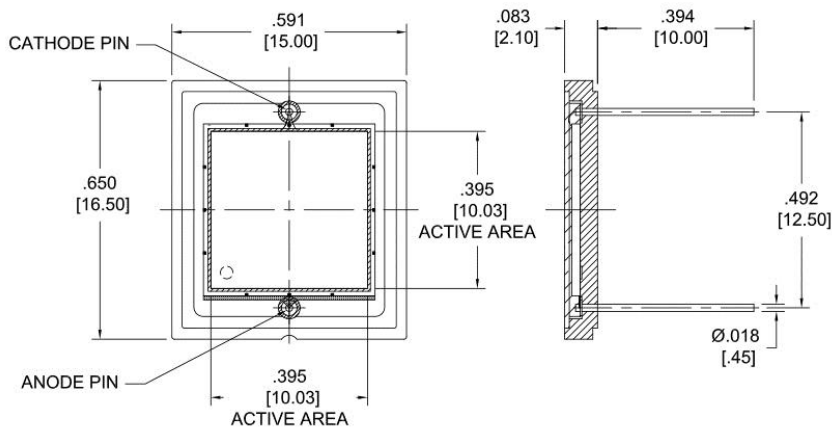

ORDERING INFORMATION

ODD-AXU-019 Ceramic Carrier with Protective Cover in Black Plastic Container

