

1. Synopsis

1-1. General Description

The 2.0SMCJ Series Has Been Designed To Protect Sensitive Equipment Against Electro-Static Discharges According to IEC 61000-4-2, MIL STD 883 Method 3015, And Electrical Over Stress Such as IEC 61000-4-4 and 5. They Are Generally For Surges Below 2000 W (10/1000 μ s).

This Technology Makes It Compatible With High-End Equipment And SMPS Where Low Leakage Current And High Junction Temperature Are Required To Provide Reliability And Stability Over Time. Their Low Clamping Voltages Provide a Better Safety Margin to Protect Sensitive Circuits With Extended Life Time Expectancy.

Packaged in SMCJ, This Minimizes PCB Space Consumption.

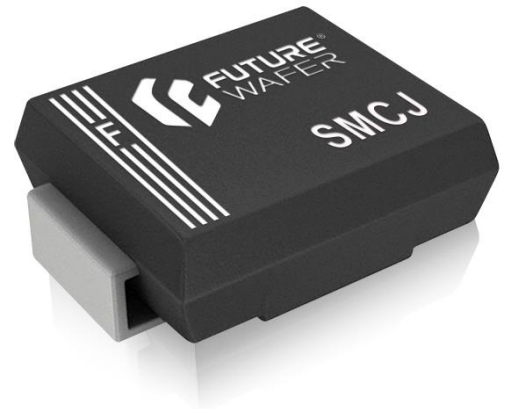

SMCJ

1-2. Feature List

- Bi / Uni-Directional Configurations
- Plastic Package Has Underwriters
- Glass Passivated Chip Junction in SMCJ Package
- 2000 Watts Peak Pulse Power ($t_p = 10/1000\mu$ s)
- Halogen Free and RoHS Compliant
- Fast Response Time: Typically Less Than
1.0ps From 0 Volts to V(BR) For Uni-Directional and
5.0ns For Bi-Directional Types
- High Temperature Soldering Guaranteed:
250°C / 10 Seconds at Terminals

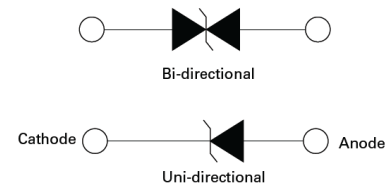

1-3. Applications

- Power Supply Protection
- Industrial Application
- Power Manager

1-4. IEC Compatibility

- EN61000-4
- 61000-4-2(ESD): Contact: > \pm 30KV, Air: > \pm 30KV
- 61000-4-4(EFT)
- 61000-4-5(Surge): 10/1000uS

1-5. Mechanical Characteristics

- Molded JEDEC SMCJ Package
- Packing: Tape and Reel
- Flammability Rating UL 94V-0
- Halogen Free
- JEDEC MSL Classification: Level 1



2. Contents

1. Synopsis	1
1-1. General Description	1
1-2. Feature List	1
1-3. Applications	1
1-4. IEC Compatibility	1
1-5. Mechanical Characteristics	1
2. Contents	2
3. Electrical Property	3
3-1. Absolute Maximum Ratings	3
3-2. Electrical Characteristics ($T_{amb}=25^{\circ}C$)	4
3-3. I-V Curve Characteristics	5
3-4. Ratings and Characteristics Curve ($T_A=25^{\circ}C$ unless otherwise noted)	5
3-4. Ratings and Characteristics Curve ($T_A=25^{\circ}C$ unless otherwise noted)	6
4. Soldering Parameters	7
5. Package Information	8
5-1. Dimension	8
5-2. PCB Pad Layout Recommendation	8
6. Packing	9
6-1. Taping and Reel Specification	9
6-2. Embossed Carrier Tape Specification	9
6-3. Surface Mount Reel Specification	10
6-4. Tape Leader and Trailer Specification	10
7. Family Members	11
8. Ordering Information	12
9. Version	12
9-1. History	12
9-2. Company Profile	12

3. Electrical Property

3-1. Absolute Maximum Ratings

Maximum Ratings@25°C Unless Otherwise Specified			
Parameter	Symbol	Value	Units
Peak Pulse Power (tp=10/1000us)	P_{PP}	2000	W
Power Dissipation On Infinite Heat Sink at $T_L = 50^\circ\text{C}$	P_D	4.5	
Peak Forward Surge Current, 8.3mS Signal Half Sine Wave Uni-Directional Only	I_{FSM}	250	A
Maximum instantaneous Forward Voltage at 100A For Uni-Direction Only	V_F	3.5	V
Operating Temperature	T_J	-55~+150	°C
Storage Temperature	T_{STG}		
Typical Thermal Resistance Junction to Lead	$R_{\theta JL}$	15	°C/W
Typical Thermal Resistance Junction to Ambient	$R_{\theta JA}$	75	

3-2. Electrical Characteristics (Tamb=25°C)

Part Number		Reverse Stand-off Voltage	Breakdown Voltage		Test Current	Reverse Leakage	Max. Clamp Voltage	Peak Pulse Current	Marking	
		V_{RWM}	$V_{BR} @ I_T$		I_T	$I_R @ V_{RWM}$	$V_C @ I_{PP}$	$I_{PP}(10/1000\mu s)$		
Uni	Bi	V	Min V	Max V	mA	μA	V	A	Uni	Bi
2000 W Surface Mount Transient Voltage Suppressors 2.0SMCJ SERIES										
2.0SMCJ5.0A	2.0SMCJ5.0CA	5.00	6.40	7.07	10.0	200.0	9.2	217.4	FGDE	FBDE
2.0SMCJ6.0A	2.0SMCJ6.0CA	6.00	6.67	7.37	10.0	200.0	10.3	194.2	FGDG	FBDG
2.0SMCJ6.5A	2.0SMCJ6.5CA	6.50	7.22	7.98	10.0	100.0	11.2	178.6	FGDK	FBDK
2.0SMCJ7.0A	2.0SMCJ7.0CA	7.00	7.78	8.60	10.0	100.0	12.0	166.7	FGDM	FBDM
2.0SMCJ7.5A	2.0SMCJ7.5CA	7.50	8.33	9.21	1.0	100.0	12.9	155.0	FGDP	FBDP
2.0SMCJ8.0A	2.0SMCJ8.0CA	8.00	8.89	9.83	1.0	100.0	13.6	147.1	FGDR	FBDR
2.0SMCJ8.5A	2.0SMCJ8.5CA	8.50	9.44	10.40	1.0	20.0	14.4	138.9	FGDT	FBDT
2.0SMCJ9.0A	2.0SMCJ9.0CA	9.00	10.00	11.10	1.0	10.0	15.4	129.9	FGDV	FBDV
2.0SMCJ10A	2.0SMCJ10CA	10.00	11.10	12.30	1.0	10.0	17.0	117.6	FGDX	FBDX
2.0SMCJ11A	2.0SMCJ11CA	11.00	12.20	13.50	1.0	1.0	18.2	109.9	FGDZ	FBDZ
2.0SMCJ12A	2.0SMCJ12CA	12.00	13.30	14.70	1.0	1.0	19.9	100.5	FGEE	FBEE
2.0SMCJ13A	2.0SMCJ13CA	13.00	14.40	15.90	1.0	1.0	21.5	93.0	FGEG	FBEG
2.0SMCJ14A	2.0SMCJ14CA	14.00	15.60	17.20	1.0	1.0	23.2	86.2	FG EK	FB EK
2.0SMCJ15A	2.0SMCJ15CA	15.00	16.70	18.50	1.0	1.0	24.4	82.0	FGEM	FBEM
2.0SMCJ16A	2.0SMCJ16CA	16.00	17.80	19.70	1.0	1.0	26.0	76.9	FGEP	FBEP
2.0SMCJ17A	2.0SMCJ17CA	17.00	18.90	20.90	1.0	1.0	27.6	72.5	FGER	FBER
2.0SMCJ18A	2.0SMCJ18CA	18.00	20.00	22.10	1.0	1.0	29.2	68.5	FGET	FBET
2.0SMCJ20A	2.0SMCJ20CA	20.00	22.20	24.50	1.0	1.0	32.4	61.7	FG EV	FB EV
2.0SMCJ22A	2.0SMCJ22CA	22.00	24.40	26.90	1.0	1.0	35.5	56.3	FG EX	FB EX
2.0SMCJ24A	2.0SMCJ24CA	24.00	26.70	29.50	1.0	1.0	38.9	51.4	FG EZ	FB EZ
2.0SMCJ26A	2.0SMCJ26CA	26.00	28.90	31.90	1.0	1.0	42.1	47.5	FG FE	FB FE
2.0SMCJ28A	2.0SMCJ28CA	28.00	31.10	34.40	1.0	1.0	45.4	44.1	FG FG	FB FG
2.0SMCJ30A	2.0SMCJ30CA	30.00	33.30	36.80	1.0	1.0	48.4	41.3	FG FK	FB FK
2.0SMCJ33A	2.0SMCJ33CA	33.00	36.70	40.60	1.0	1.0	53.3	37.5	FG FM	FB FM
2.0SMCJ36A	2.0SMCJ36CA	36.00	40.00	44.20	1.0	1.0	58.1	34.4	FG FP	FB FP
2.0SMCJ40A	2.0SMCJ40CA	40.00	44.40	49.10	1.0	1.0	64.5	31.0	FG FR	FB FR
2.0SMCJ43A	2.0SMCJ43CA	43.00	47.80	52.80	1.0	1.0	69.4	28.8	FG FT	FB FT
2.0SMCJ45A	2.0SMCJ45CA	45.00	50.00	55.30	1.0	1.0	72.7	27.5	FG FV	FB FV
2.0SMCJ48A	2.0SMCJ48CA	48.00	53.30	58.90	1.0	1.0	77.4	25.8	FG FX	FB FX
2.0SMCJ51A	2.0SMCJ51CA	51.00	56.70	62.70	1.0	1.0	82.4	24.3	FG FZ	FB FZ
2.0SMCJ54A	2.0SMCJ54CA	54.00	60.00	66.30	1.0	1.0	87.1	23.0	FG GE	FB GE
2.0SMCJ58A	2.0SMCJ58CA	58.00	64.40	71.20	1.0	1.0	93.0	21.5	FG GG	FB GG
2.0SMCJ60A	2.0SMCJ60CA	60.00	66.70	73.70	1.0	1.0	96.0	20.8	FG GK	FB GK
2.0SMCJ64A	2.0SMCJ64CA	64.00	71.10	78.60	1.0	1.0	103.0	19.4	FG GM	FB GM
2.0SMCJ70A	2.0SMCJ70CA	70.00	77.80	86.00	1.0	1.0	113.0	17.7	FG GP	FB GP
2.0SMCJ75A	2.0SMCJ75CA	75.00	83.30	92.10	1.0	1.0	121.0	16.5	FG GR	FB GR
2.0SMCJ78A	2.0SMCJ78CA	78.00	86.70	95.80	1.0	1.0	126.0	15.9	FG GT	FB GT
2.0SMCJ85A	2.0SMCJ85CA	85.00	94.40	104.00	1.0	1.0	137.0	14.6	FG GV	FB GV
2.0SMCJ90A	2.0SMCJ90CA	90.00	100.00	111.00	1.0	1.0	146.0	13.7	FG GX	FB GX
2.0SMCJ100A	2.0SMCJ100CA	100.00	111.00	123.00	1.0	1.0	162.0	12.3	FG GZ	FB GZ
2.0SMCJ110A	2.0SMCJ110CA	110.00	122.00	135.00	1.0	1.0	177.0	11.3	FG HE	FB HE
2.0SMCJ120A	2.0SMCJ120CA	120.00	133.00	147.00	1.0	1.0	193.0	10.4	FG HG	FB HG
2.0SMCJ130A	2.0SMCJ130CA	130.00	144.00	159.00	1.0	1.0	209.0	9.6	FG HK	FB HK
2.0SMCJ150A	2.0SMCJ150CA	150.00	167.00	185.00	1.0	1.0	243.0	8.2	FG HM	FB HM
2.0SMCJ160A	2.0SMCJ160CA	160.00	178.00	197.00	1.0	1.0	259.0	7.7	FG HP	FB HP
2.0SMCJ170A	2.0SMCJ170CA	170.00	189.00	209.00	1.0	1.0	275.0	7.3	FG HR	FB HR
2.0SMCJ180A	2.0SMCJ180CA	180.00	200.00	220.00	1.0	1.0	291.6	6.9	FG HT	FB HT
2.0SMCJ190A	2.0SMCJ190CA	190.00	211.00	232.00	1.0	1.0	307.8	6.5	FG HV	FB HV

3-3. I-V Curve Characteristics

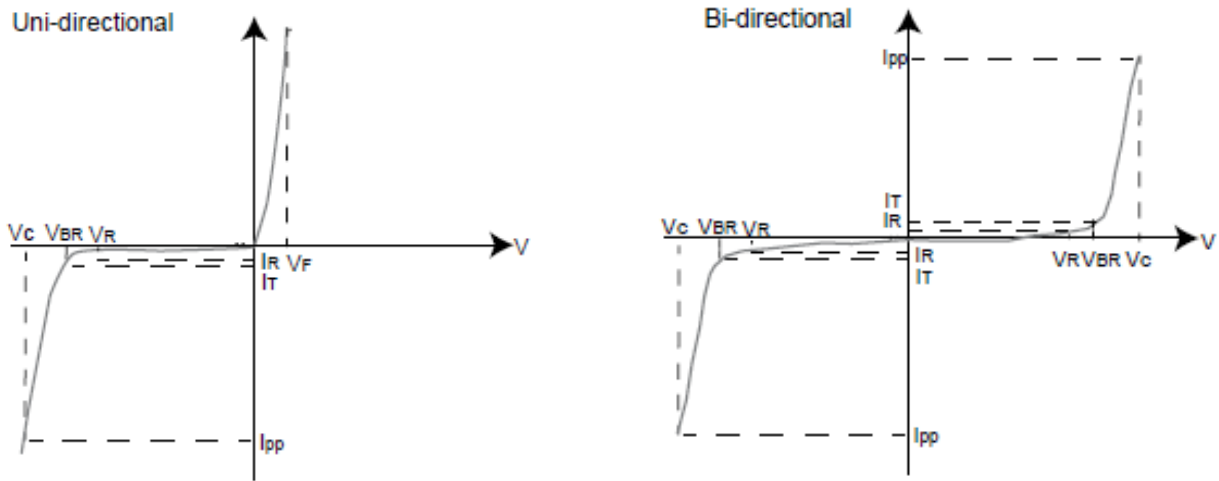

- P_{PPM}** **Peak Pulse Power Dissipation**-Max Power Dissipation
- V_R** **Stand-off Voltage**-Maximum Voltage That Can be Applied to The TVS Without Operation
- I_R** **Reverse Leakage Current**-Current Measured at V_R
- V_F** **Forward Voltage Drop for Uni-directional**
- V_{BR}** **Breakdown Voltage**-Maximum Voltage that Flows Though the TVS at a Specified Test Current (I_T)
- V_C** **Clamping Voltage**-Peak Voltage Measured Across the Suppressor at a Specified I_{ppm}
(Peak Impulse Current)

3-4. Ratings and Characteristics Curve (TA=25°C unless otherwise noted)

Fig 1. Peak Pulse Power Rating Curve

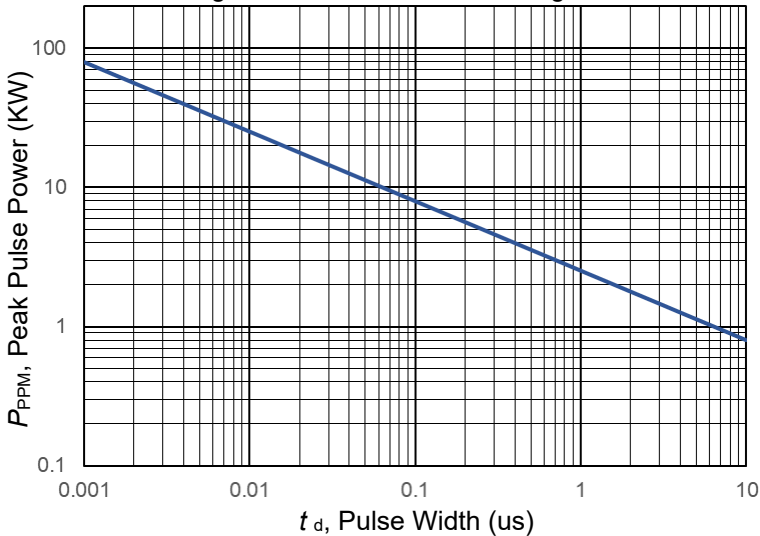
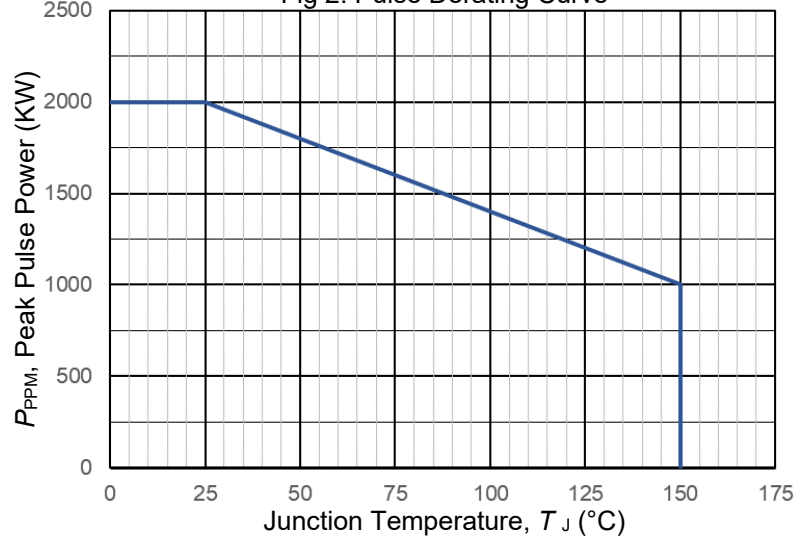

Fig 2. Pulse Derating Curve



3-4. Ratings and Characteristics Curve ($T_A=25^\circ\text{C}$ unless otherwise noted)

Fig 3. Maximum Non-repetitive Forward Surge Current Uni-direction Only

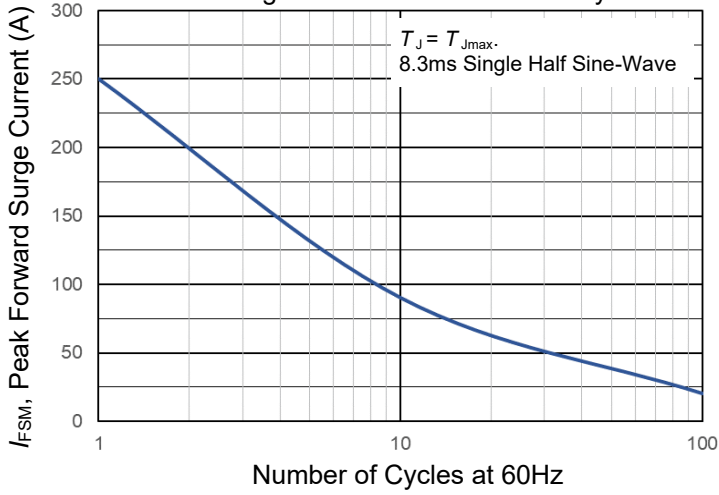

Fig 4. Typical Junction Capacitance

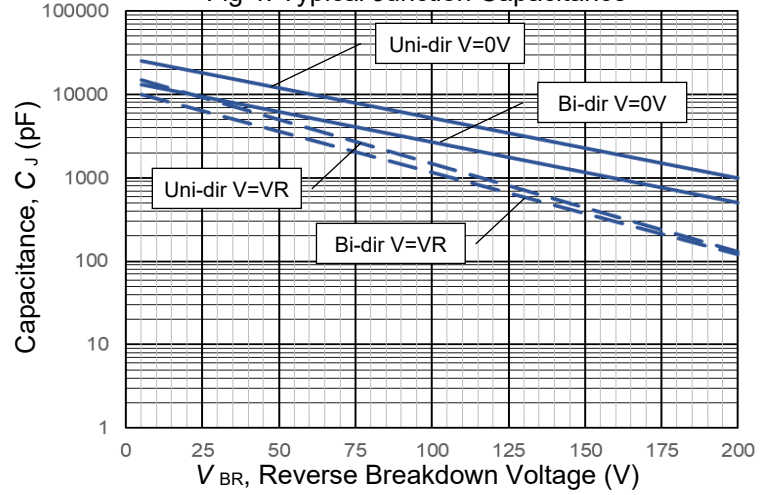

Fig 5. Maximum Forward Voltage

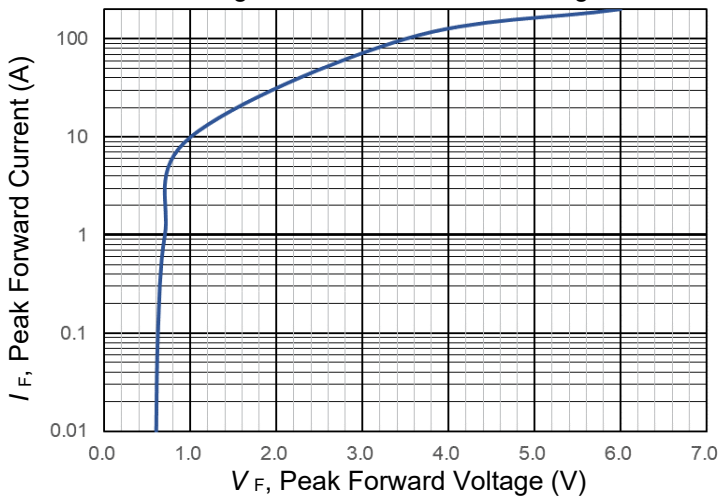

Fig 6. Typical Transient Thermal Impedance

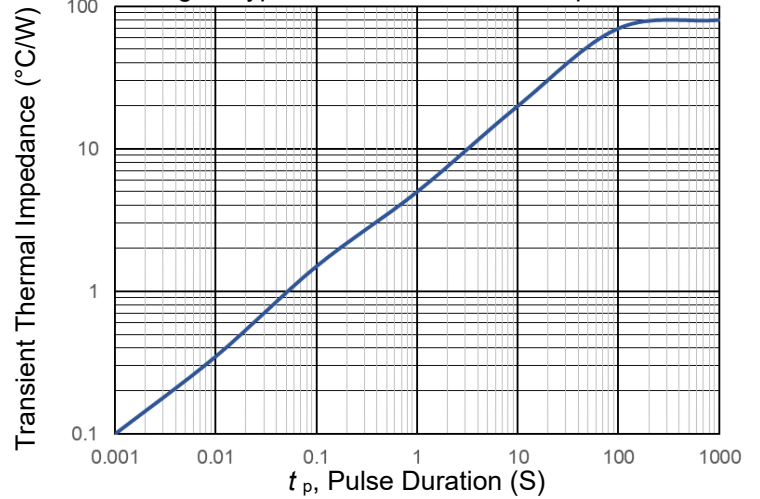
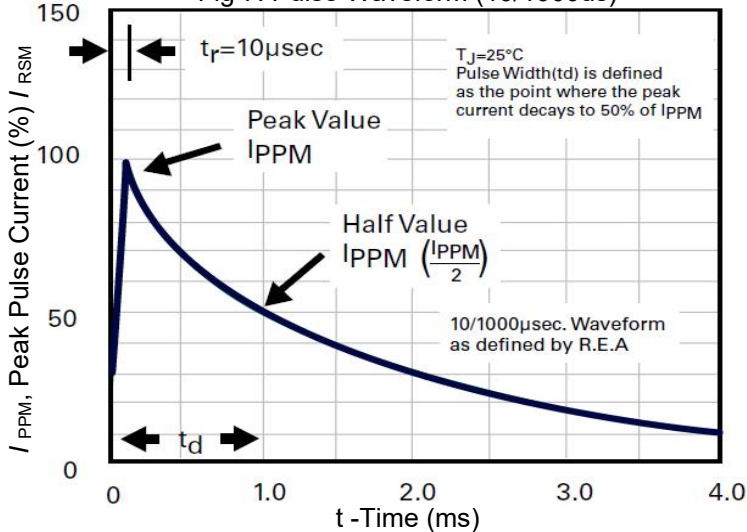

Fig 7. Pulse Waveform (10/1000us)



4. Soldering Parameters

Profile Feature	SnPb eutectic assembly	Pb-free assembly
Average ramp-up rate (T _{smax} to T _p)	3 °C/s maximum	3 °C/s maximum
Preheat		
Temperature minimum (T _{smin})	100 °C	150 °C
Temperature maximum (T _{smax})	150 °C	200 °C
Time (t _{smin} to t _{smax})	60 s to 120 s	60 s to 180 s
Time maintained above		
Temperature (T _L)	183 °C	217 °C
Time (t _L)	60 s to 150 s	60 s to 150 s
Peak/classification temperature (T)	235 °C	260 °C
Number of allowed reflow cycles	3	3
Time within 5 °C of actual peak temperature (t _p)	10 s to 30 s	20 s to 40 s
Ramp-down rate	6 °C/s maximum	6 °C/s maximum
Time 25 °C to peak temperature	6 minutes maximum	8 minutes maximum

temperature

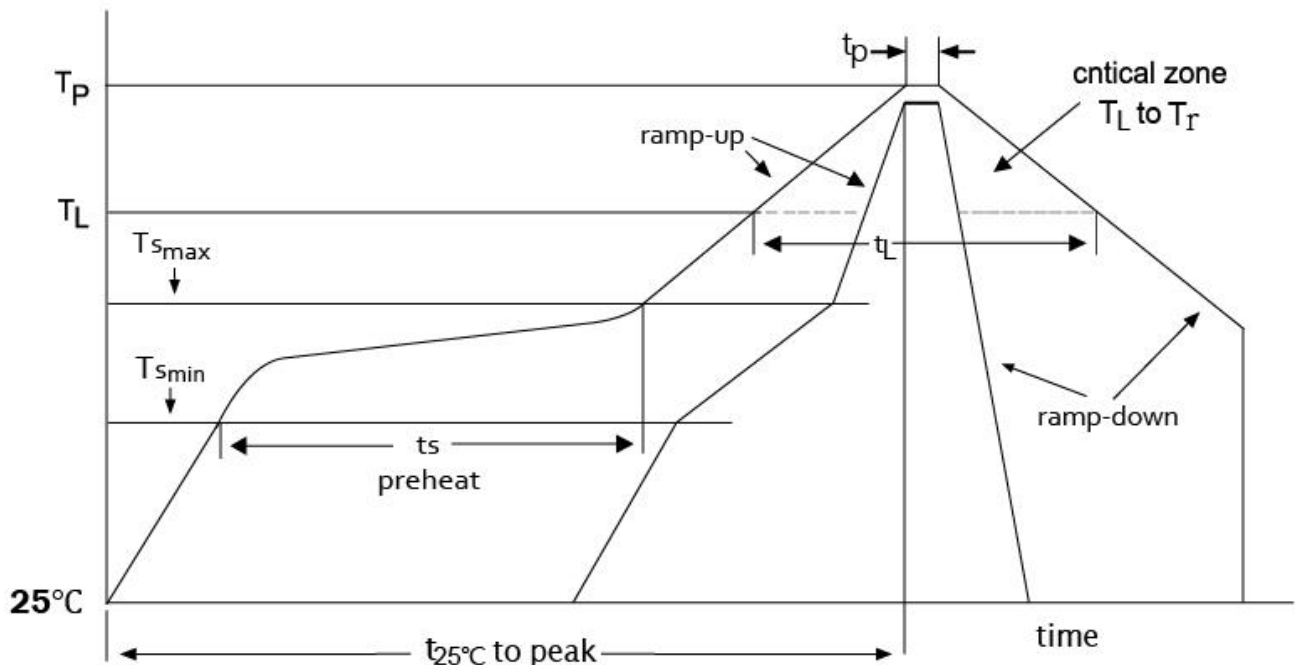

5. Package Information

5-1. Dimension

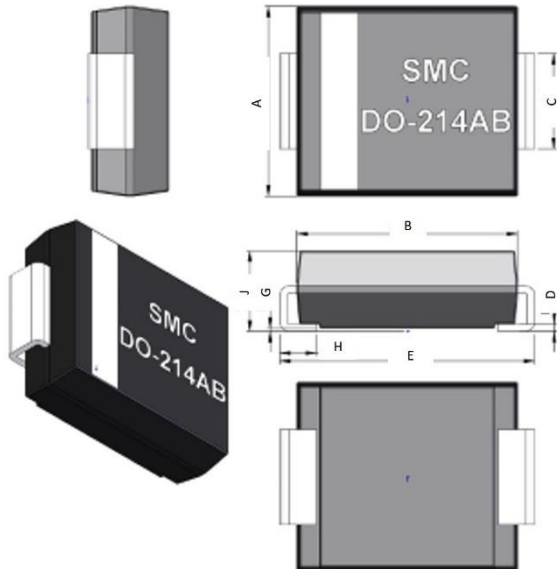

SMCJ		
Dim	Min.	Max.
A	5.67	6.15
B	6.75	7.05
C	2.80	3.10
D	0.10	0.20
E	7.65	8.15
G	0.04	0.16
H	0.90	1.60
J	2.05	2.95

Unit:mm

5-2. PCB Pad Layout Recommendation

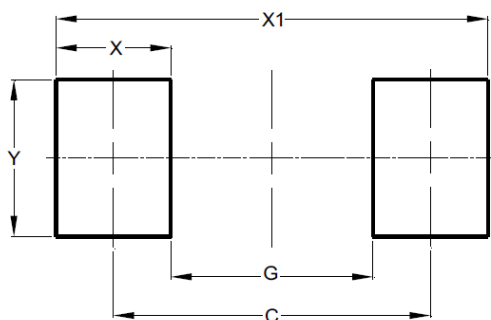

Dimensions	Value
C	6.90
G	4.40
X	2.50
X1	9.40
Y	3.30

Unit:mm

6. Packing

6-1. Taping and Reel Specification

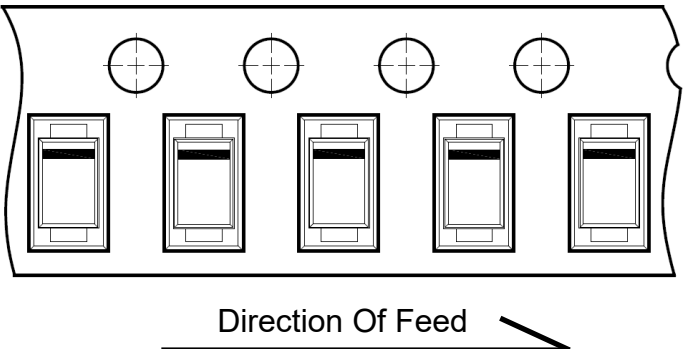
Taping Width	Tape Orientation
16mm	

6-2. Embossed Carrier Tape Specification

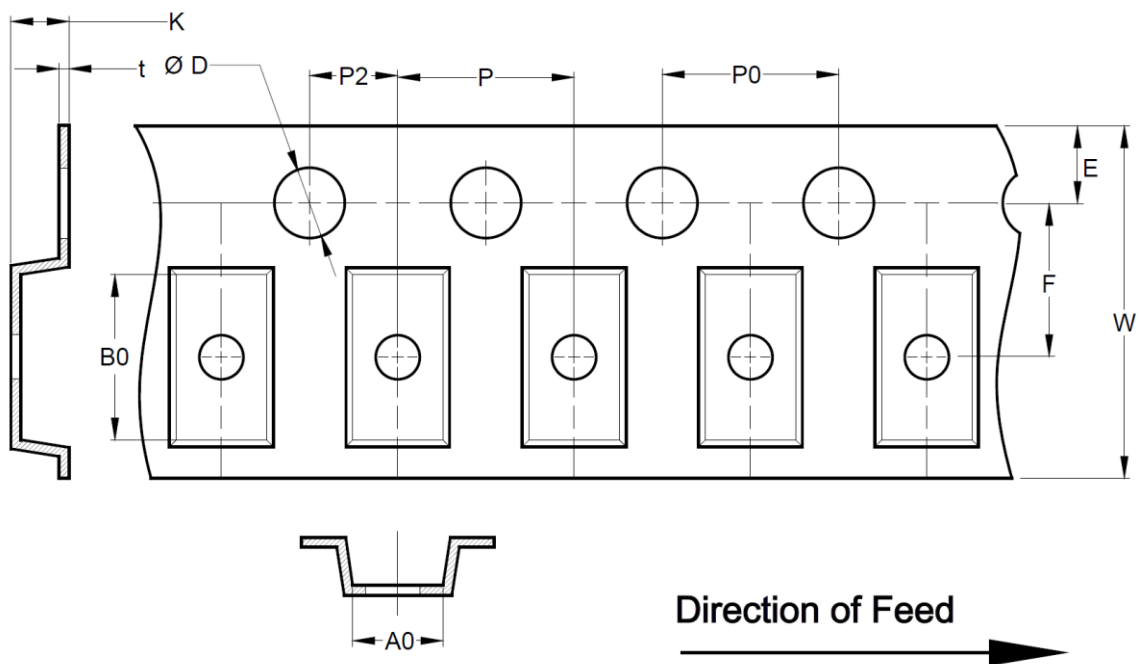

Unit:mm

Dimension	W	D	D1	E	F	K	P	P0	P2	t
Value	16 mm	1.5 +0.1/-0.0	1.4 mm	1.75 ±0.10	7.5 ±0.10	3.7 Max.	8.0 ±0.10	4.0 ±0.10	2.0 ±0.10	0.4 Max.
A0 / B0 / K0	Determined by Component Size. The Clearance Between The Component And The Cavity Must Comply to The Rotational and Lateral Movement Requirement Provided in Figures in The "Maximum Component Movement in Tape Pocket" Section.									

6-3. Surface Mount Reel Specification

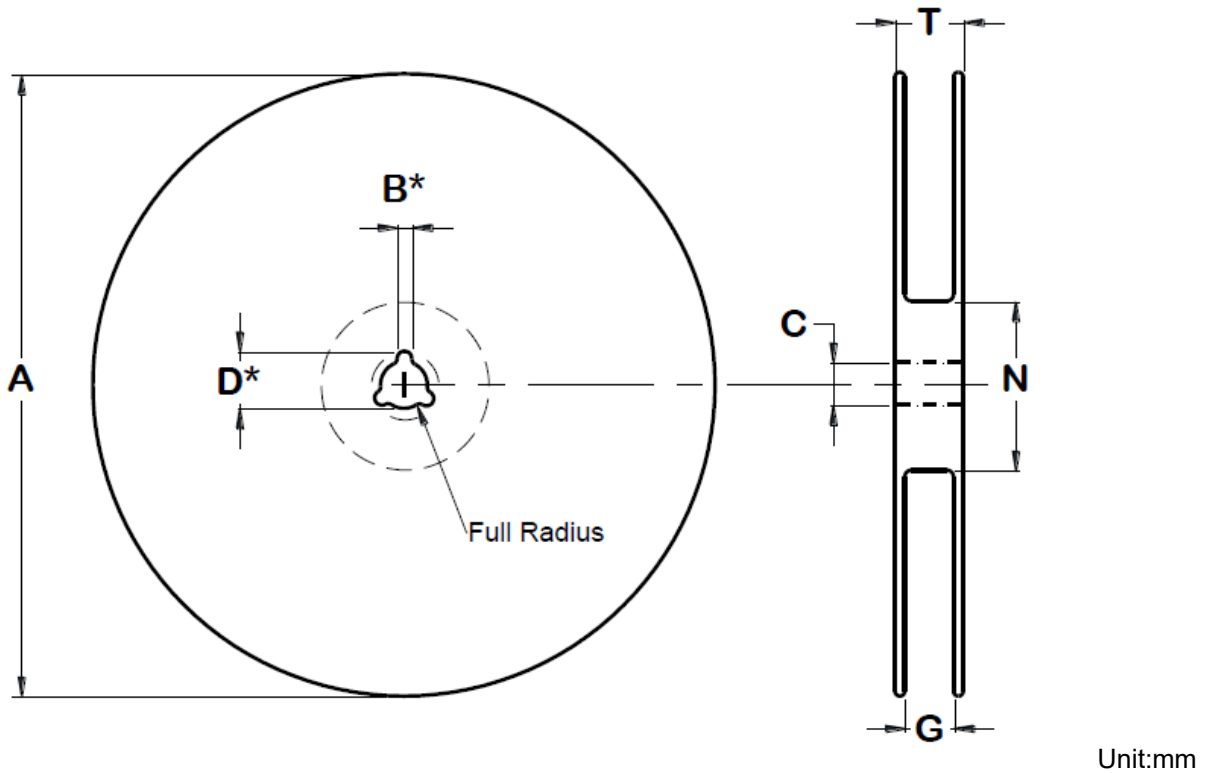

Unit:mm

Dimension	Tape Width	Reel Size	A	B	C	D	N	G	T
Value	16 mm	13"	330 ±2	2.0 +0.5-0	13 +0.5-0.2	20.5 ±0.2	100 ±5	16.4 +1.5/-0.0	22.4

6-4. Tape Leader and Trailer Specification

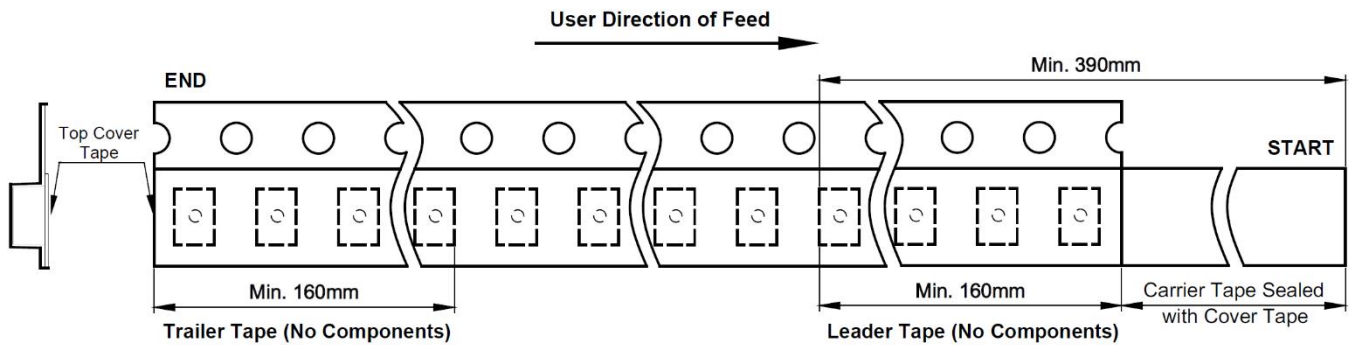

7. Family Members

Part Number	Component Package	Watts	Working Voltage $V_{RWM}(V)$	
SMF Series	SOD-123FL	300W	5.0V ~ 190V	
NVS4M Series		400W	5.0V ~ 58V	
NVS4D Series	DFN2020-3L	400W	3.3V ~ 58V	
SMAJ Series	SMAJ	400W	5.0V ~ 190V	
SMA6J Series		600W	12V ~ 58V	
NVS6A Series	SMAF	600W	12V ~ 58V	
SMBJ Series	SMBJ	600W	5.0V ~ 190V	
SMB10J Series		1000W		
NVS15B Series	SMBF	1500W	5.0V ~ 58V	
SMPJ Series	TO-277	1500W	5.0V ~ 200V	
SMCJ Series	SMCJ	1500W	5.0V ~ 190V	
2.0SMCJ Series		2000W		
3.0SMCJ Series		3000W		
4.0SMCJ Series		4000W		12V ~ 58V
5.0SMCJ Series		5000W		12V ~ 170V
6KA Series		6600W		21V ~ 58V
5KP Series		P600		5000W
10KP Series	10000W		17V ~ 180V	
15KP Series	15000W			
20KP Series	20000W		20V ~ 180V	

8. Ordering Information

Part Number	Marking Code	Quantity	Component Package	Packaging Option
2.0SMCJxxA	Series	3,000PCS	SMCJ	13"reel
2.0SMCJxxCA				

9. Version

9-1. History

Version	Date	File No.	Recording	Basis
2.0	16-May-2021	F12121X	New Create	System
2.1	19-Jul-2021		Update Version	System