

Product Features:

Surface Mount Package
 Reflow Compatible
 Compatible with Leadfree Processing

Applications:

Test Equipment
 Server & Storage
 Sonet /SDH

Frequency	180 MHz to 622.08 MHz
Output Level LVDS LVPECL	V _{od} = 393 mV Typ., 475 mV Max. '0' = V _{cc} - 1.63 V Max. '1' = V _{cc} - 1.02 V Min.
Duty Cycle	Specify 50% ±10% or ±5% See Table in Part Number Guide
Rise / Fall Time	0.6 nS Max.
Output Load LVDS LVPECL	100 Ω Differential 50 Ω to V _{cc} - 2.0 VDC
Frequency Stability	See Frequency Stability Table in Part Number Guide (Includes room temperature tolerance and stability over operating temperature)
Start-up Time	10 mS Max.
Enable / Disable Time	100 nS Max.
Supply Voltage	See Input Voltage Table, tolerance ±5 %
Current	LVDS = 90 mA Max. *** LVPECL = 130 mA Max. ***
RMS Phase Jitter	0.5 Typical, 1 ps Max. (12 kHz to 20 MHz)
Operating	See Operating Temperature Table in Part Number Guide
Storage	-55° C to +125° C

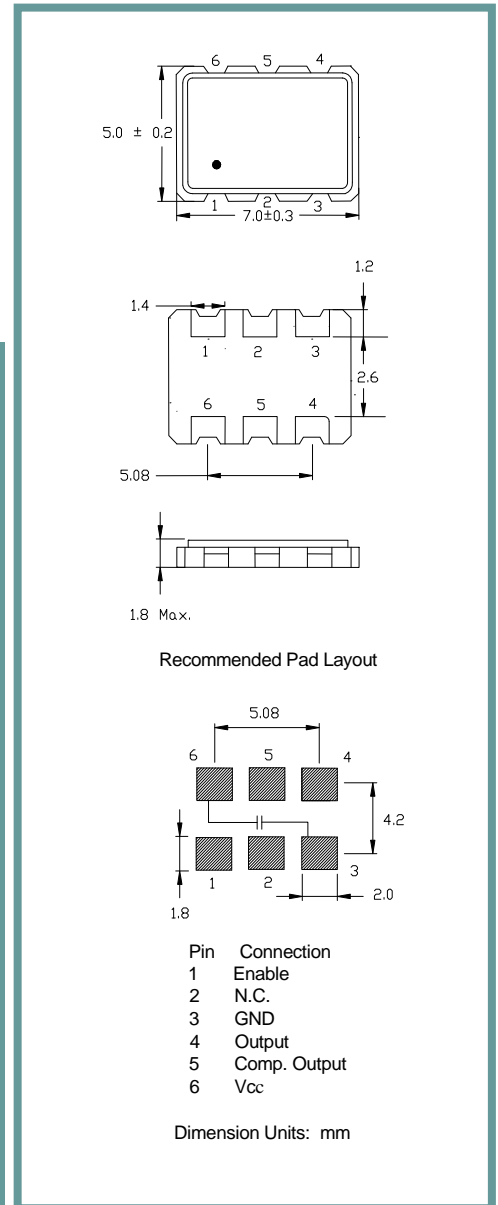

Part Number Guide		Sample Part Number: ISM99 - 3159BH - 180.000					
Package	Input Voltage	Operating Temperature	Symmetry (Duty Cycle)	Output	Stability (in ppm)	Enable / Disable	Frequency
ISM99 -	3 = 3.3 V	1 = 0° C to +70° C	5 = 45 / 55 Max.	8 = LVDS	**A = ±25	H = Enable	- 180.000 MHz
	7 = 3.0 V	6 = -10° C to +70° C	6 = 40 / 60 Max.	9 = LVPECL	B = ±50		
	2 = 2.7 V	3 = -20° C to +70° C			C = ±100		
	6 = 2.5 V	4 = -30° C to +75° C					
		2 = -40° C to +85° C					

NOTE: A 0.01 µF bypass capacitor is recommended between V_{cc} (pin 6) and GND (pin 3) to minimize power supply noise.

** Not available for all temperature ranges. *** Frequency, supply, and load related parameters.



5 mm x 7 mm Ceramic Package SMD Oscillator, LVPECL / LVDS



ISM99 Series

Pb Free Solder Reflow Profile:

Typical Application:

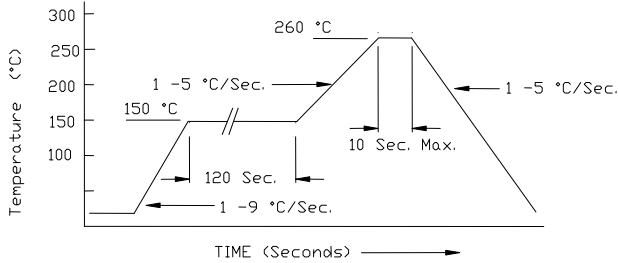

*Units are backward compatible with 240C reflow processes

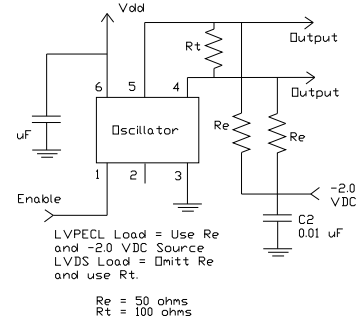

Package Information:

MSL = N.A. (package does not contain plastic, storage life is unlimited under normal room conditions).
 Termination = e4 (Au over Ni over W base metalization).

Tape and Reel Information:

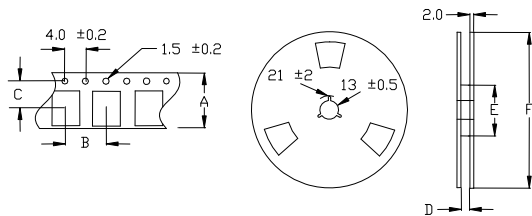

Quantity per Reel	1000
A	16 +/- .3
B	8 +/- .2
C	7.5 +/- .2
D	17.5 +/- 1
E	50 / 60 / 80
F	180 / 250

Environmental Specifications

Thermal Shock	MIL-STD-883, Method 1011, Condition A
Moisture Resistance	MIL-STD-883, Method 1004
Mechanical Shock	MIL-STD-883, Method 2002, Condition B
Mechanical Vibration	MIL-STD-883, Method 2007, Condition A
Resistance to Soldering Heat	J-STD-020C, Table 5-2 Pb-free devices (except 2 cycles max)
Hazardous Substance	Pb-Free / RoHS / Green Compliant
Solderability	JESD22-B102-D Method 2 (Preconditioning E)
Terminal Strength	MIL-STD-883, Method 2004, Test Condition D
Gross Leak	MIL-STD-883, Method 1014, Condition C
Fine Leak	MIL-STD-883, Method 1014, Condition A2, R1=2x10 ⁻⁸ atm cc/s
Solvent Resistance	MIL-STD-202, Method 215

Marking

Line 1: ILSI and Date Code (YWW)
 Line 2: Frequency