

# KLM - 064MA - 16B

This module designed for light emitting display device. Organize with 16 x 32 matrix combination with 512 of each Red, Green LED Chips, for indoor use.

**FEATURES**

- Active display size : 64mm x 128mm
- Dot size :  $\phi 3$
- Dot pitch : 4mm
- Display color : RED, GREEN, AMBER(Mixed color)
- Duty rate : 1/16
- Dot matrix : 512(16 x 32)
- Weight : 150g(Typ.)
- With a simple serial - inter face.

**MAXIMUM RATINGS**

(Ta=25 )

ITEM	SYMBOL	RATING	UNIT	COND.
Power dissipation	$P_D$	25	W	
Supply voltage(DRIVE)	$V_{DD}$	6	V	
Supply voltage(LED)	$V_{LED}$	6	V	
Logic input power	$V_{in}$	- 0.5 ~ $V_{DD}$	V	
Junction Temp.	$T_J$	115		
Operating Temp.	$T_{opr}$	- 20 ~ +60		
Storage Temp.	$T_{stg}$	- 20 ~ +65		

**DIMENSIONS**

(Unit : mm)

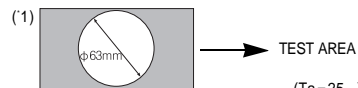
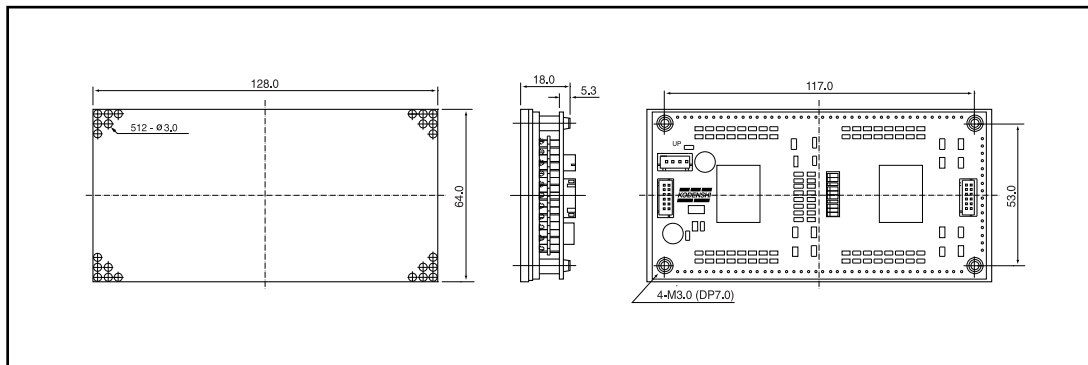

**OPTICAL CHARACTERISTICS**

(Ta=25 )

ITEM	SYMBOL	CONDITION	MIN.	TYP.	MAX.	UNIT.
Bright - ness(16x 16)	GREEN	$V_{DD}=5V$	-	120	-	$cd/m^2$
	RED		-	100	-	
	AMBER		-	180	-	
Dot - Balance	GREEN	$V_{LED}=5V$	-	-	2	-
	RED		-	-	2	
	AMBER		-	-	2	
Emission Wavelength	GREEN		-	565	-	nm
	RED		-	630	-	
Spectrum half - band	GREEN		-	25	-	nm
	RED		-	40	-	

# LED Dot Matrix

## KLM - 064MA - 16B

### ELECTRICAL CHARACTERISTICS(VOLTAGE CURRENT CHARACTERISTICS)

(Ta=25 )

ITEM	SYMBOL	CONDITION	MIN.	TYP.	MAX.	UNIT.	
Supply voltage(LOGIC)	V <sub>DD</sub>	-	4.75	5	5.25	V	
Supply voltage(LED)	V <sub>LED</sub>	-	4.50	5	5.50	V	
Supply current(LOGIC)	I <sub>DD</sub>	V <sub>DD</sub> =5V	-	50.0	70.0	mA	
Supply current(LED)	GREEN	I <sub>LEDg</sub>	Lighting all <sup>1,2</sup>	-	-	2.4	A
	RED	I <sub>LEDr</sub>		-	-	2.2	
	AMBER	I <sub>LEDo</sub>		-	-	3.6	
Logic - input vol tage LOW	V <sub>L</sub>	V <sub>LED</sub> =5V	-	-	1.5	V	
Logic - input vol tage HIGH	V <sub>H</sub>	V <sub>DD</sub> =5V	3.5	-	-	V	

\*2. V<sub>DD</sub>=5V, V<sub>LED</sub>=5V

\*PULL UP

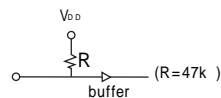

### ELECTRICAL CHARACTERISTICS (CONNECTOR SPECIFICATION)

CLASSIFICATION	NAME	STANDARD	LENGH	COMPANY	REMARK	
POWER CONN.	WAFER	B 4B - XH - A	-	KST	JST C/N	
INPUT SIGNAL CONN.	WAFER	B 12B - PHDSS	-	KST	JST C/N	
OUTPUT SIGNAL CONN.	WAFER	B 12B - PHDSS	-	KST	JST C/N	
ASS Y	POWER	HARNESS	XHP - 4P - 000(Ring type)	Option	KST	JST C/N
		HARNESS	XHP - 4P - 000(Solder type)	Option	KST	JST C/N
	SIGNAL	HARNESS	HPDR - 12VS - 000	Option	KST	JST C/N

### BLOCK DIAGRAM

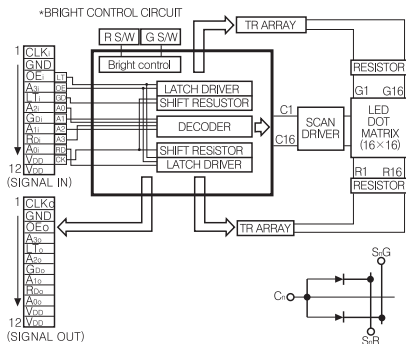

### TIMING CHART

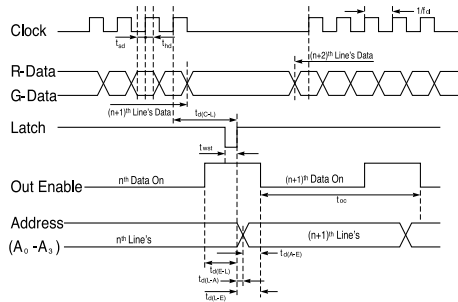

### RECOMMENDED TIMING CONDITION

NO	ITEM	SYMBOL	MIN.	TYP.	MAX.	UNIT.
1	CLOCK FREQUENCY	f <sub>cl</sub>	-	-	40	MHz
2	CLOCK CYCLE	1/f <sub>cl</sub>	25	-	-	ns
3	CLOCK - LATCH TIME	t <sub>d(C-L)</sub>	25	-	-	ns
4	LATCH PULSE WIDTH	t <sub>wt</sub>	25	-	-	ns
5	ENABLE - LATCH TIME	t <sub>d(E-L)</sub>	0	-	-	ns
6	DATA SETUP TIME	t <sub>sd</sub>	6	-	-	ns
7	DATA HOLD TIME	t <sub>hd</sub>	6	-	-	ns
8	ADDRESS - ENABLE TIME	t <sub>d(A-E)</sub>	25	-	-	ns
9	LATCH - ADDRESS TIME	t <sub>d(L-A)</sub>	0	-	-	ns
10	LATCH - ENABLE TIME	t <sub>d(L-E)</sub>	0	-	-	ns
11	ENABLE CYCLE	t <sub>oc</sub>	-	-	1	ms