

Motor Drivers for Digital Still Cameras

5-Channel System Lens Driver for Digital Still Cameras

BD6758MWV BD6758KN
General Description

The BD6758MWV and BD6758KN are motor drivers that integrate 4 Full-ON type H-Bridges and 1 Linear Constant-Current type H-Bridge. These devices are intended to drive a stepping motor for auto focus system, and to drive DC motors for zoom and iris.

Features

- Low ON-Resistance Power CMOS Output
- Drive Mode Switch Function
- High-Precision($\pm 3\%$) Linear Constant-Current Driver
- Phase Compensation Capacitor-Free Design for Linear Constant-Current Drive Block
- High-Precision ($1.2V \pm 3\%$) Reference Voltage
- Under Voltage Locked Out Protection & Thermal Shut Down Circuit

Applications

- Mobile system
- Home appliance
- Amusement system, etc

Key Specifications

- Power Supply Voltage Range: 2.5V to 5.5V
- Motor Power Supply Voltage Range: 2.5V to 5.5V
- Circuit Current(No Signal & No Load): 1.4mA(Typ)
- Stand-By Current: 10 μ A(Max)
- Control Input Voltage Range: 0V to V_{CC} V
- H-Bridge Output Current: -0.5A/ch to +0.5A/ch
- Output ON-Resistance(Channel 1 to 4): 1.2 Ω (Typ)
- Output ON-Resistance(Channel 5): 1.0 Ω (Typ)
- Operating Temperature Range: -25°C to +85°C

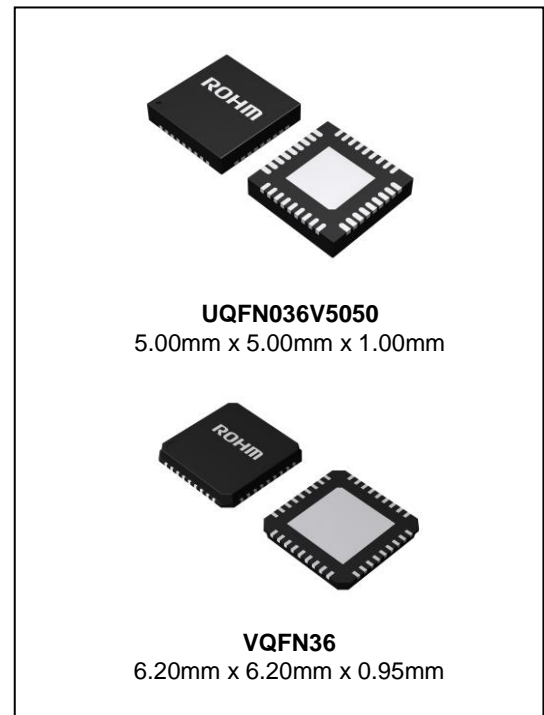
Package
W(Typ) x D(Typ) x H(Max)

Typical Application Circuit

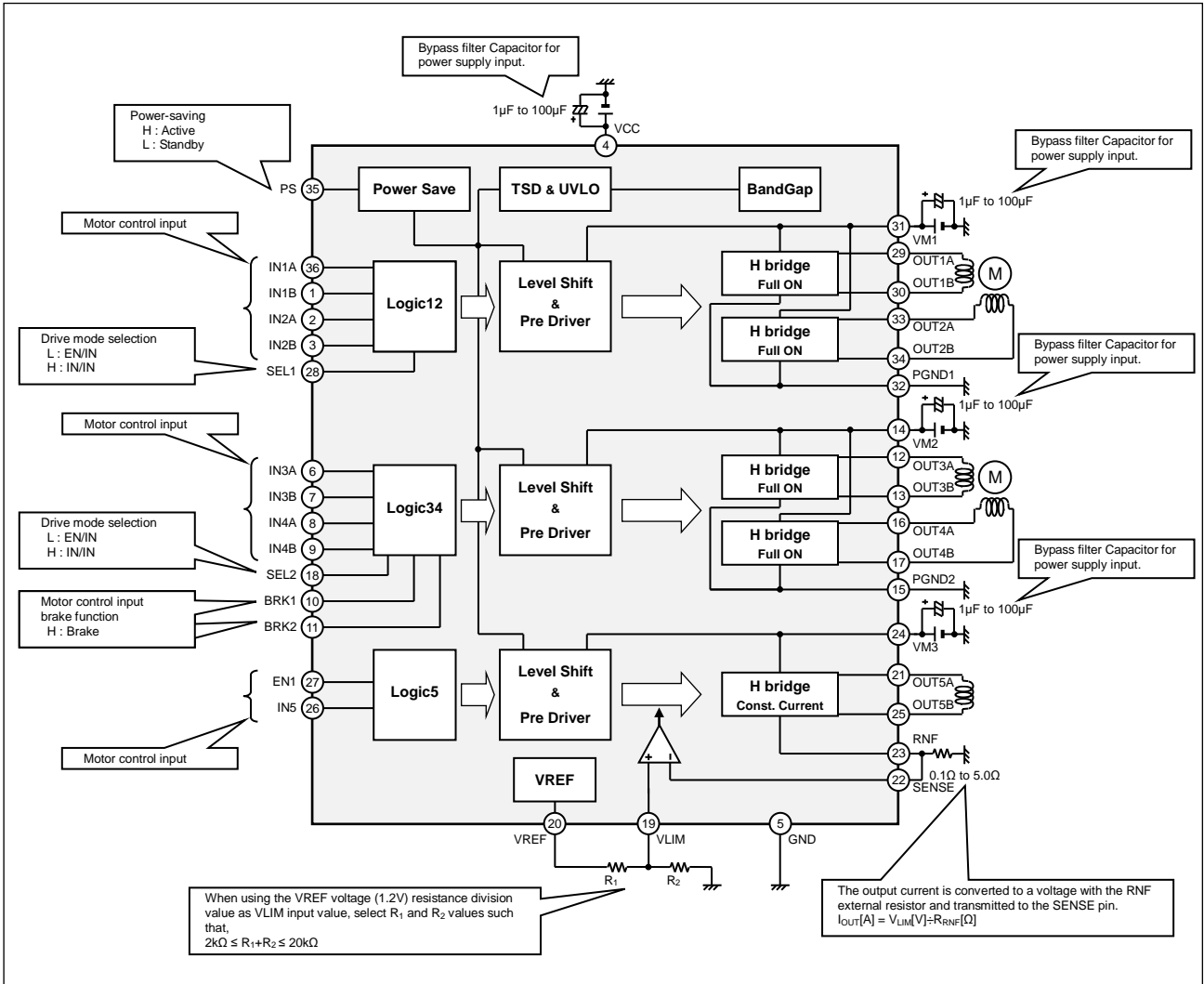

Pin Configurations

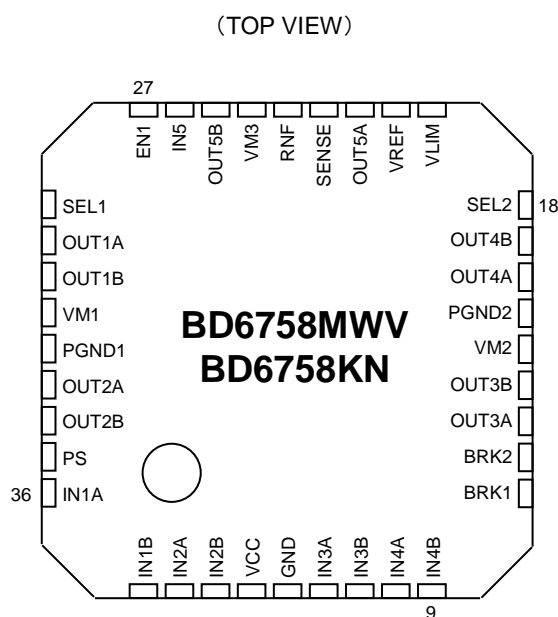

Pin Descriptions

Pin No.	Pin Name	Function	Pin No.	Pin Name	Function
1	IN1B	Control logic input 1B	19	VLIM	Output current setting ch.5
2	IN2A	Control logic input 2A	20	VREF	Reference voltage output
3	IN2B	Control logic input 2B	21	OUT5A	H-bridge output 5A
4	VCC	Power supply	22	SENSE	Output current detection ch.5
5	GND	Ground	23	RNF	Current detect resistor ch.5
6	IN3A	Control logic input 3A	24	VM3	Motor power supply ch.5
7	IN3B	Control logic input 3B	25	OUT5B	H-bridge output 5B
8	IN4A	Control logic input 4A	26	IN5	Control logic input ch.5
9	IN4B	Control logic input 4B	27	EN1	Control logic input ch.5
10	BRK1	Control logic input ch.3	28	SEL1	Drive mode select ch.1 & ch.2
11	BRK2	Control logic input ch.4	29	OUT1A	H-bridge output 1A
12	OUT3A	H-bridge output 3A	30	OUT1B	H-bridge output 1B
13	OUT3B	H-bridge output 3B	31	VM1	Motor power supply ch.1 & ch.2
14	VM2	Motor power supply ch.3 & ch.4	32	PGND1	Motor ground ch.1 & ch.2
15	PGND2	Motor ground ch.3 & ch.4	33	OUT2A	H-bridge output 2A
16	OUT4A	H-bridge output 4A	34	OUT2B	H-bridge output 2B
17	OUT4B	H-bridge output 4B	35	PS	Power saving
18	SEL2	Drive mode select ch.3 & ch.4	36	IN1A	Control logic input 1A

Block Diagram

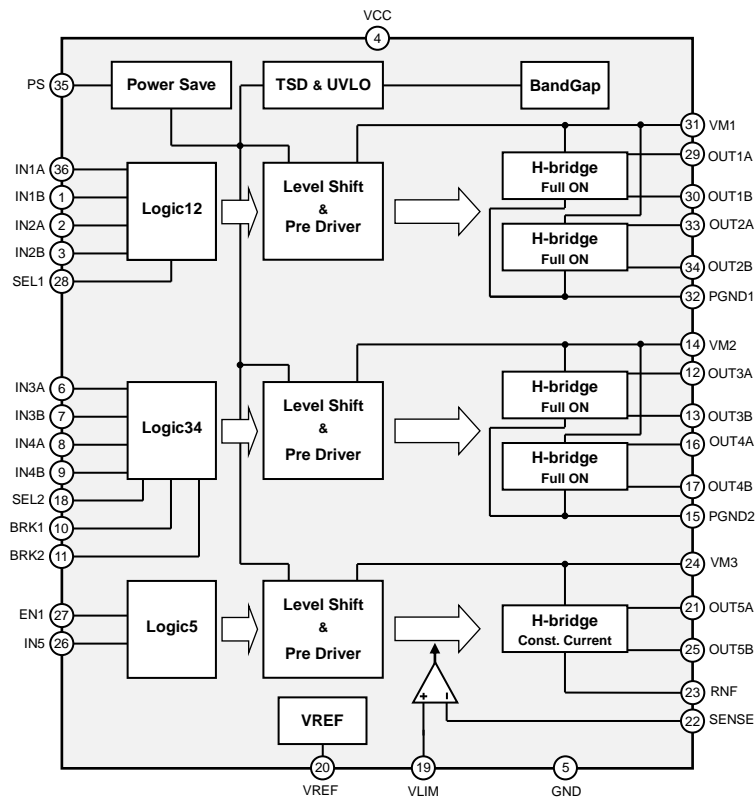

Description of Blocks

1. Power-Saving Function

A power-saving function is included, which allows the system to save power when not driving the motor. The voltage level on this pin should be set high so as to keep the operation mode. (See the Electrical Characteristics; p.6/16)

2. Motor Control Input

(a) IN1A to IN5B, EN1, and IN5 Pins

Logic level controls the output logic of H-Bridge.

(See the Electrical Characteristics; p.6/16, and I/O Truth Table; p.8/16)

(b) SEL1 & SEL2 Pins

Logic level sets the IN/IN or EN/IN drive mode.

(See the Electrical Characteristics; p.6/16 and I/O Truth Table; p.8/16)

(c) BRK1 & BRK2 Pins

In case of EN/IN mode, logic high puts the device in short brake mode.

(See the Electrical Characteristics; p.6/16, and I/O Truth Table; p.8/16)

3. H-Bridge

Each H-bridge can be controlled independently. It is therefore possible to drive the H-bridges simultaneously, as long as the package thermal tolerances are not exceeded. Because the respective output transistors consist of power CMOS which consumes a motor power supply V_M , the ON-Resistance value of high and low-side total is dependent on V_M voltage. Further, the whole application must be designed so that the maximum current of each channel may be 500mA or below. (See the Recommended Operating Conditions; p.6/16)

Description of Blocks – continued

4. Drive System of Linear Constant-Current H-bridge (Channel 5)

(a) Reference Output Voltage (with a tolerance of $\pm 3\%$)

The VREF pin can output 1.2V based on the internal reference voltage. The output current of the Constant-Current Drive block can be controlled by connecting external resistor to the VREF pin and setting the voltage which is divided by the resistor to the output current setting pin (VLIM pin). It is recommended to place the external 2k Ω or above resistor in consideration of the load current capacity of the VREF pin, and to place the 20k Ω or below resistor in order to minimize the fluctuation caused by the base current of the internal transistor.

(b) Output Current Detection and Current Settings

A low-value (0.1 Ω to 5.0 Ω) resistor can be placed between the RNF pin and ground to detect the motor winding current. When making the RNF and SENSE pins short-circuit, the internal circuits can output the accurate constant current by comparing the VLIM voltage with detecting voltage. To make more accurate motor winding current, trim the external RNF resistor, and supply VLIM pin with another precise external voltage. In case of this condition, VREF pin should be kept open.

$$\text{Output Current Value } I_{\text{OUT}}[\text{A}] = \text{VLIM}[\text{V}] / \text{RNF}[\Omega]$$

The motor winding current will be equal to 400mA $\pm 3\%$, if 0.2V is set to the VLIM pin and a 0.5 Ω external resistor is connected to the RNF pin. If the VLIM pin is shorted to the VCC pin (or the same voltage as the VCC is set) and the SENSE and RNF pins are shorted to the ground, this channel can drive as a Full-ON type H-bridge like other channels.

Absolute Maximum Ratings (Ta=25°C)

Parameter	Symbol	Limit		Unit
		BD6758MWV	BD6758KN	
Power Supply Voltage	V _{CC}	0 to +7.0	0 to +7.0	V
Motor Power Supply Voltage	V _M	0 to +7.0	0 to +7.0	V
Control Input Voltage	V _{IN}	0 to +V _{CC}	0 to +V _{CC}	V
Power Dissipation	P _d	0.88 (Note 1)	0.87 (Note 2)	W
H-bridge Output Current	I _{OUT}	-0.8 to +0.8 (Note 3)	-0.8 to +0.8 (Note 3)	A/ch
Storage Temperature Range	T _{stg}	-55 to +150	-55 to +150	°C
Junction Temperature	T _{jmax}	150	150	°C

(Note 1) Reduced by 7.04mW/°C over 25°C, when mounted on a glass epoxy board (74.2mm x 74.2mm x 1.6mm)

(Note 2) Reduced by 6.96mW/°C over 25°C, when mounted on a glass epoxy board (70mm x 70mm x 1.6mm)

(Note 3) Must not exceed P_d, A_{SO}, or T_{jmax} of 150°C

Caution: Operating the IC over the absolute maximum ratings may damage the IC. The damage can either be a short circuit between pins or an open circuit between pins and the internal circuitry. Therefore, it is important to consider circuit protection measures, such as adding a fuse, in case the IC is operated over the absolute maximum ratings.

Recommended Operating Conditions

Parameter	Symbol	BD6758MWV			BD6758KN			Unit
		Min	Typ	Max	Min	Typ	Max	
Power Supply Voltage	V _{CC}	2.5	-	5.5	2.5	-	5.5	V
Motor Power Supply Voltage	V _M	2.5	-	5.5	2.5	-	5.5	V
Control Input Voltage	V _{IN}	0	-	V _{CC}	0	-	V _{CC}	V
H-bridge Output Current (Note 4)	I _{OUT}	-0.5	-	+0.5	-0.5	-	+0.5	A/ch
Control Input Frequency (Note 5)	f _{IN}	0	-	100	0	-	100	kHz
Operating Temperature Range	Topr	-25	-	+85	-25	-	+85	°C

(Note 4) Must not exceed P_d, A_{SO}, or T_{jmax} of 150°C

(Note 5) ON duty=50%

Electrical Characteristics (Unless otherwise specified V_{CC}=3.0V, V_M=5.0V, Ta=25°C)

Parameter	Symbol	Min	Typ	Max	Unit	Conditions
All Circuits						
Stand-by Current	I _{CCST}	-	0	10	μA	V _{PS} =0V
Circuit Current	I _{CC}	-	1.4	2.5	mA	V _{PS} =3V with no signal and no load
Control Input (IN=PS, IN1A to IN4B, SEL1, SEL2, BRK1, BRK2, EN1, IN5)						
High Level Input Voltage	V _{INH}	2.0	-	V _{CC}	V	
Low Level Input Voltage	V _{INL}	0	-	0.7	V	
High Level Input Current	I _{INH}	15	30	60	μA	V _{IN} =3V
Low Level Input Current	I _{INL}	-1	0	-	μA	V _{IN} =0V
Pull-down Resistor	R _{IN}	50	100	200	kΩ	
Under Voltage Locked Out (UVLO)						
UVLO Voltage	V _{UVLO}	1.6	-	2.4	V	
Full ON Type H-Bridge Driver (Channel 1 to Channel 4)						
Output ON-Resistance	R _{ON}	-	1.2	1.5	Ω	I _{OUT} =±400mA, High & Low-side total
Linear Constant-Current Drive Block (Channel 5)						
Output ON-Resistance	R _{ON}	-	1.0	1.25	Ω	I _{OUT} =±400mA, High & Low-side total
VREF Output Voltage	V _{REF}	1.16	1.20	1.24	V	I _{OUT} =0mA to 1mA
Output Limit Voltage	V _{OL}	194	200	206	mV	R _{RNF} =0.5Ω, V _{VLM} =0.2V

Typical Performance Curves (Reference Data)

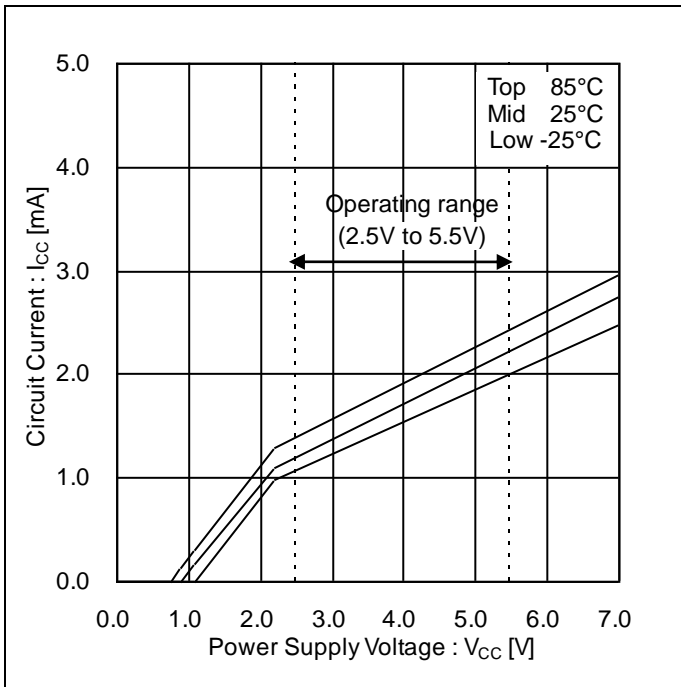

Figure 1.
Circuit Current vs Supply Voltage

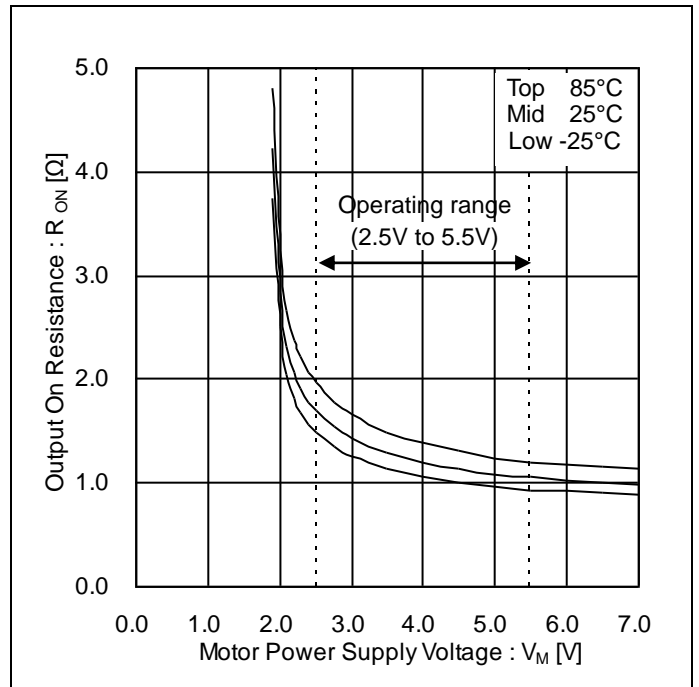

Figure 2.
Output ON-Resistance vs Motor Power Supply Voltage
(Channel 1 to Channel 4, Vcc=3V)

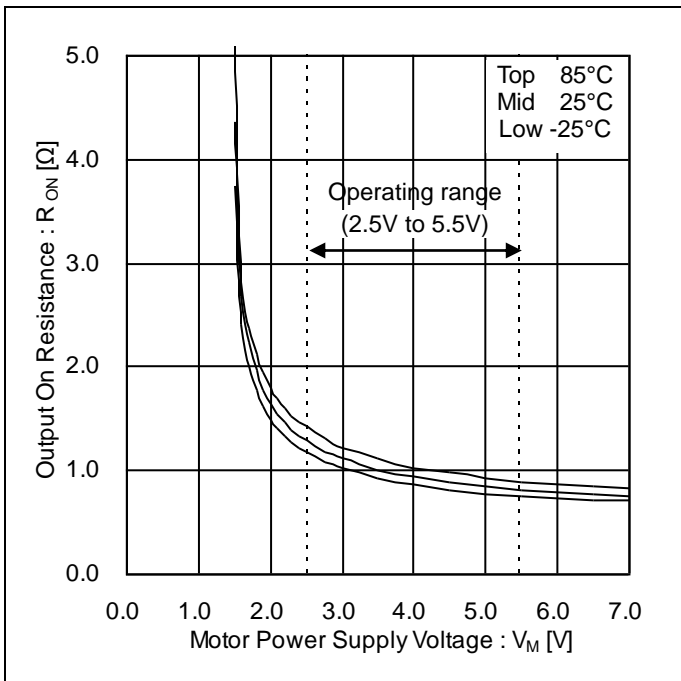

Figure 3.
Output ON-Resistance vs Motor Power Supply Voltage
(Channel 5, Vcc=3V)

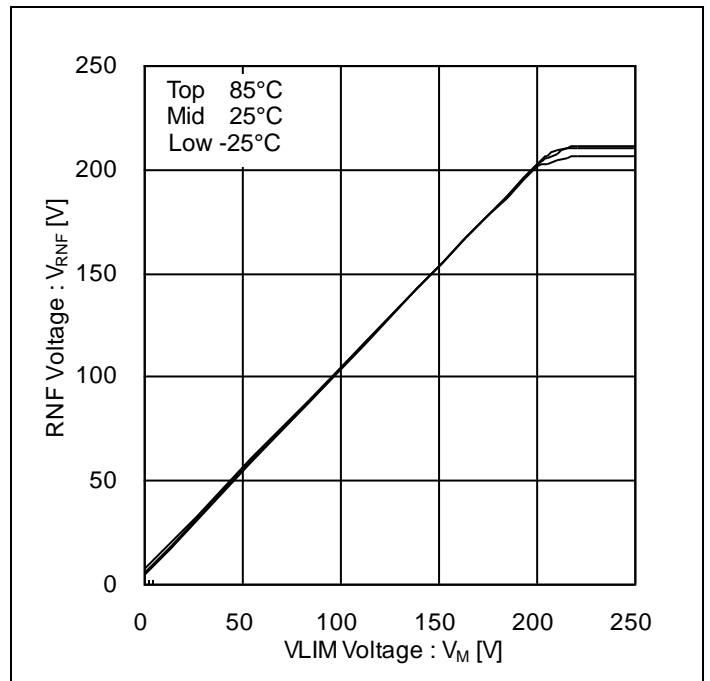

Figure 4.
RNF Voltage vs VLIM Voltage
(Output Limit Voltage, R_{RNF}=0.5Ω)

Timing Chart

Table 1. I/O Truth Table (Channel 1 & Channel 2)

Input Mode	INPUT			OUTPUT		
	SEL1	INxA	INxB	OUTxA	OUTxB	Output Mode ^(Note 6)
EN/IN	L	H	X	Z	Z	Open
		L	L	H	L	CW
		L	H	L	H	CCW
IN/IN	H	L	L	Z	Z	Open
		H	L	H	L	CW
		L	H	L	H	CCW
		H	H	L	L	Short Brake

L: Low, H: High, X: Don't care, Z: Hi impedance

(Note 6) CW: Current flows from OUTxA to OUTxB, CCW: Current flows from OUTxB to OUTxA (x=1, 2)

Table 2. I/O Truth Table (Channel 3 & Channel 4)

Input Mode	INPUT				OUTPUT		
	SEL2	INxA	INxB	BRKx	OUTxA	OUTxB	Output Mode ^(Note 7)
EN/IN	L	H	X	X	Z	Z	Open
		L	L	L	H	L	CW
		L	H	L	L	H	CCW
		L	X	H	L	L	Short Brake
IN/IN	H	L	L	X	Z	Z	Open
		H	L	X	H	L	CW
		L	H	X	L	H	CCW
		H	H	X	L	L	Short Brake

L: Low, H: High, X: Don't care, Z: Hi impedance

(Note 7) CW: Current flows from OUTxA to OUTxB, CCW: Current flows from OUTxB to OUTxA (x=3,4)

Table 3. I/O Truth Table (Channel 5)

Input Mode	INPUT		OUTPUT		
	EN1	IN5	OUT5A	OUT5B	Output Mode ^(Note 8)
EN/IN	H	X	Z	Z	Open
	L	L	H	L	CW
	L	H	L	H	CCW

L: Low, H: High, X: Don't care, Z: Hi impedance

(Note 8) CW: Current flows from OUT5A to OUT5B, CCW: Current flows from OUT5B to OUT5A

Application Example

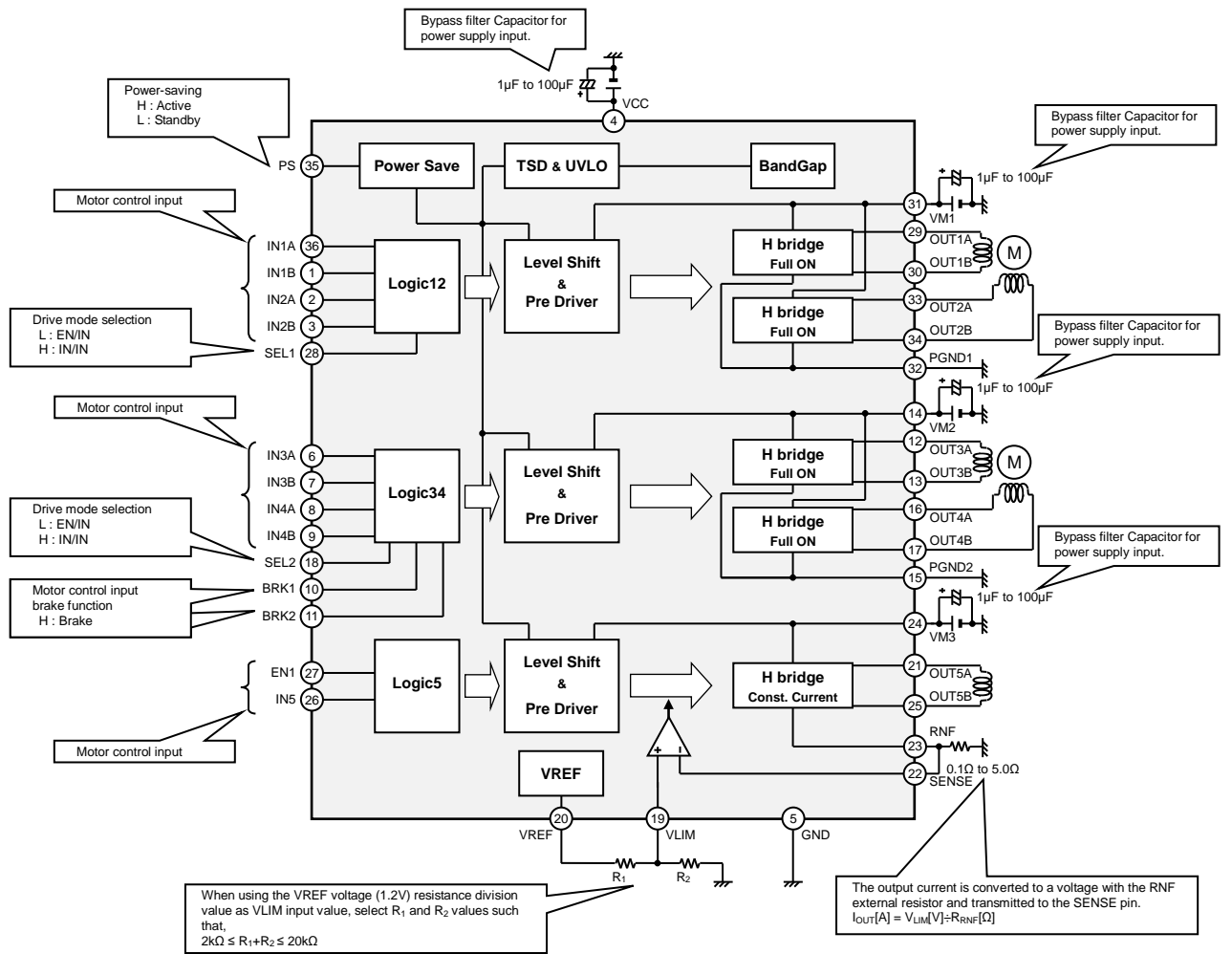

Selection of Components Externally Connected

When using the circuit with changes to the external circuit constants, make sure to leave an adequate margin for external components including static and transitional characteristics as well as dispersion of the IC.

Power Dissipation

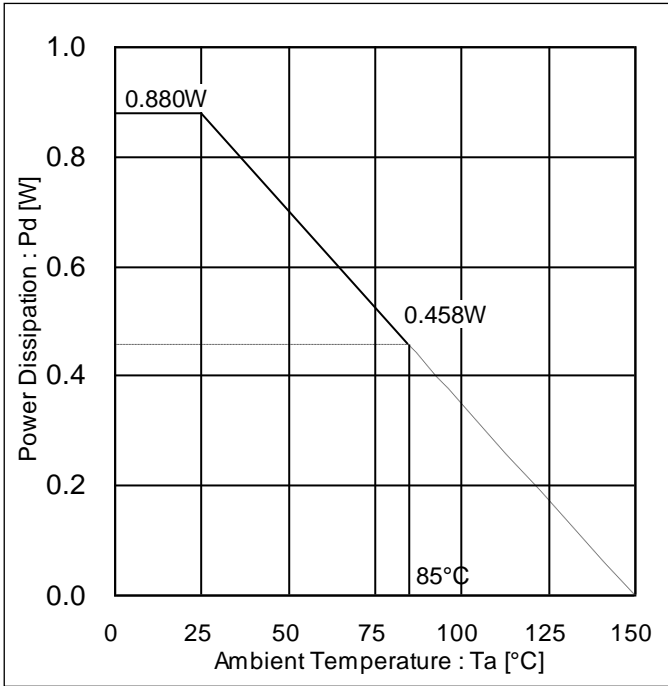

Figure 5. BD6758MWV
Power Dissipation vs Ambient Temperature

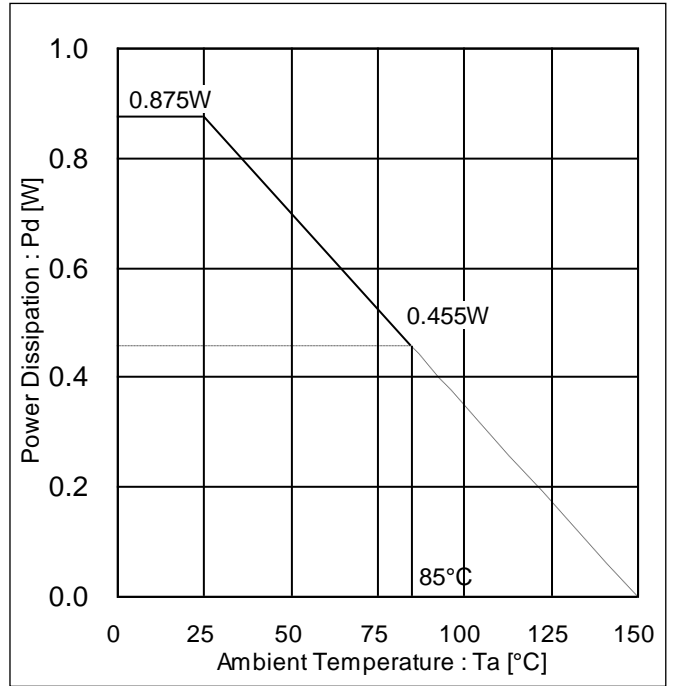
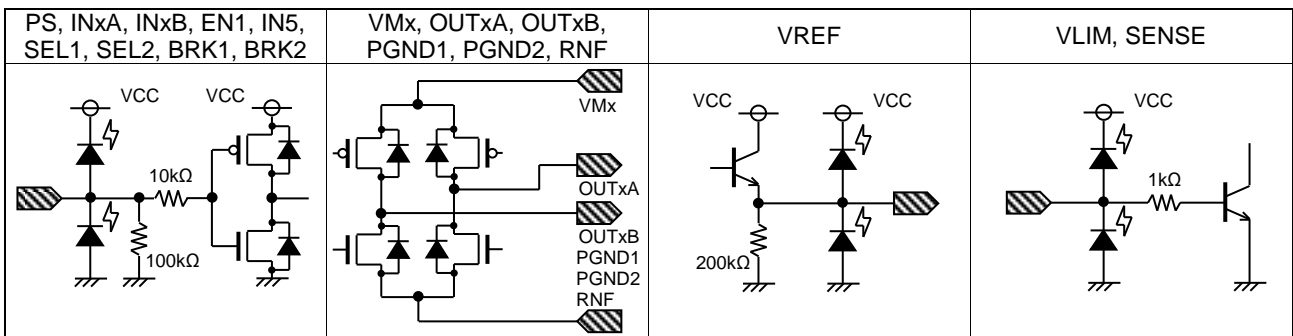

Figure 6. BD6758KN
Power Dissipation vs Ambient Temperature

I/O Equivalent Circuits



Operational Notes

1. Reverse Connection of Power Supply

Connecting the power supply in reverse polarity can damage the IC. Take precautions against reverse polarity when connecting the power supply, such as mounting an external diode between the power supply and the IC's power supply pins.

2. Power Supply Lines

Design the PCB layout pattern to provide low impedance supply lines. Separate the ground and supply lines of the digital and analog blocks to prevent noise in the ground and supply lines of the digital block from affecting the analog block. Furthermore, connect a capacitor to ground at all power supply pins. Consider the effect of temperature and aging on the capacitance value when using electrolytic capacitors.

3. Ground Voltage

Ensure that no pins are at a voltage below that of the ground pin at any time, even during transient condition.

4. Ground Wiring Pattern

When using both small-signal(GND) and large-current ground(PGND) traces, the two ground traces should be routed separately but connected to a single ground at the reference point of the application board to avoid fluctuations in the small-signal ground caused by large currents. Also ensure that the ground traces of external components do not cause variations on the ground voltage. The ground lines must be as short and thick as possible to reduce line impedance.

5. Thermal Consideration

Should by any chance the power dissipation rating be exceeded the rise in temperature of the chip may result in deterioration of the properties of the chip. In case of exceeding this absolute maximum rating, increase the board size and copper area to prevent exceeding the Pd rating.

6. Recommended Operating Conditions

These conditions represent a range within which the expected characteristics of the IC can be approximately obtained. The electrical characteristics are guaranteed under the conditions of each parameter.

7. Inrush Current

When power is first supplied to the IC, it is possible that the internal logic may be unstable and inrush current may flow instantaneously due to the internal powering sequence and delays, especially if the IC has more than one power supply. Therefore, give special consideration to power coupling capacitance, power wiring, width of ground wiring, and routing of connections.

8. Operation Under Strong Electromagnetic Field

Operating the IC in the presence of a strong electromagnetic field may cause the IC to malfunction.

9. Testing on Application Boards

When testing the IC on an application board, connecting a capacitor directly to a low-impedance output pin may subject the IC to stress. Always discharge capacitors completely after each process or step. The IC's power supply should always be turned off completely before connecting or removing it from the test setup during the inspection process. To prevent damage from static discharge, ground the IC during assembly and use similar precautions during transport and storage.

10. Inter-pin Short and Mounting Errors

Ensure that the direction and position are correct when mounting the IC on the PCB. Incorrect mounting may result in damaging the IC. Avoid nearby pins being shorted to each other especially to ground, power supply and output pin. Inter-pin shorts could be due to many reasons such as metal particles, water droplets (in very humid environment) and unintentional solder bridge deposited in between pins during assembly to name a few.

11. Unused Input Pins

Input pins of an IC are often connected to the gate of a MOS transistor. The gate has extremely high impedance and extremely low capacitance. If left unconnected, the electric field from the outside can easily charge it. The small charge acquired in this way is enough to produce a significant effect on the conduction through the transistor and cause unexpected operation of the IC. So unless otherwise specified, unused input pins should be connected to the power supply or ground line.

Operational Notes – continued

12. Regarding the Input Pin of the IC

This monolithic IC contains P+ isolation and P substrate layers between adjacent elements in order to keep them isolated. P-N junctions are formed at the intersection of the P layers with the N layers of other elements, creating a parasitic diode or transistor. For example (refer to figure below):

When $GND > Pin A$ and $GND > Pin B$, the P-N junction operates as a parasitic diode.

When $GND > Pin B$, the P-N junction operates as a parasitic transistor.

Parasitic diodes inevitably occur in the structure of the IC. The operation of parasitic diodes can result in mutual interference among circuits, operational faults, or physical damage. Therefore, conditions that cause these diodes to operate, such as applying a voltage lower than the GND voltage to an input pin (and thus to the P substrate) should be avoided.

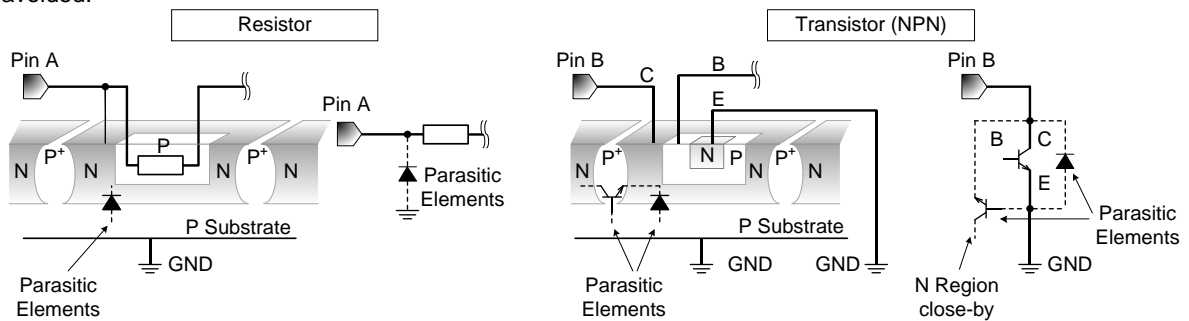

Figure 7.

Example of monolithic IC structure

13. Ceramic Capacitor

When using a ceramic capacitor, determine the dielectric constant considering the change of capacitance with temperature and the decrease in nominal capacitance due to DC bias and others.

14. Area of Safe Operation (ASO)

Operate the IC such that the output voltage, output current, and power dissipation are all within the Area of Safe Operation (ASO).

15. Thermal Shutdown Circuit(TSD)

This IC has a built-in thermal shutdown circuit that prevents heat damage to the IC. Normal operation should always be within the IC's power dissipation rating. If however the rating is exceeded for a continued period, the junction temperature (T_j) will rise which will activate the TSD circuit that will turn OFF all output pins. When the T_j falls below the TSD threshold, the circuits are automatically restored to normal operation.

Note that the TSD circuit operates in a situation that exceeds the absolute maximum ratings and therefore, under no circumstances, should the TSD circuit be used in a set design or for any purpose other than protecting the IC from heat damage.

Ordering Information

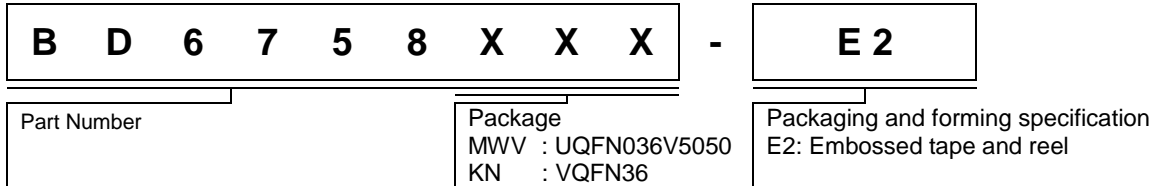

Marking Diagrams

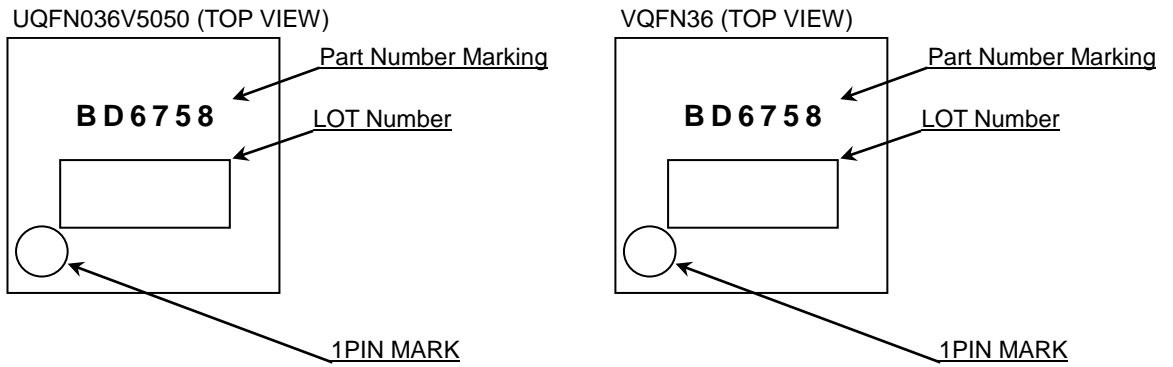

Part Number Marking	Package	Orderable Part Number
BD6758	UQFN036V5050	BD6758MWV-E2
BD6758	VQFN36	BD6758KN-E2

Physical Dimension, Tape and Reel Information

Package Name	UQFN036V5050
--------------	--------------

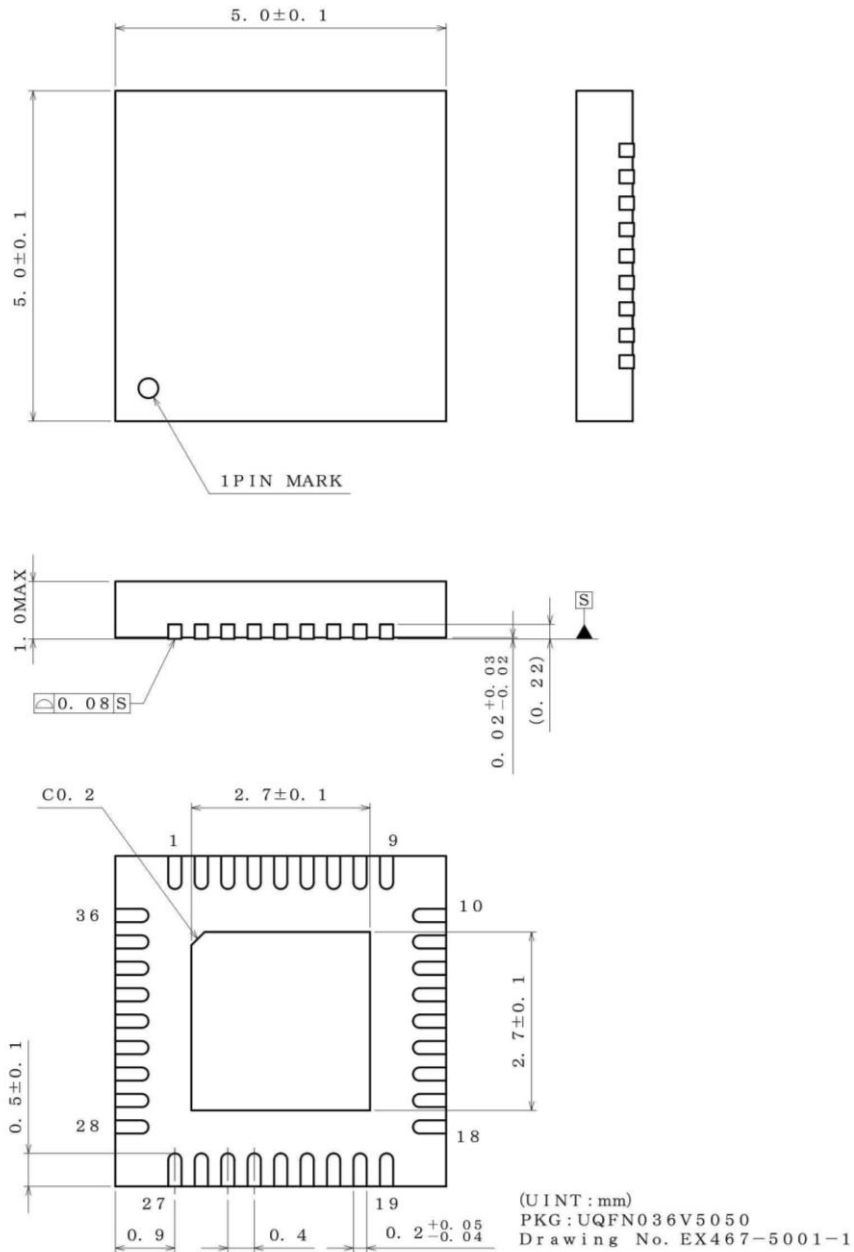

<Tape and Reel information>

Tape	Embossed carrier tape
Quantity	2500pcs
Direction of feed	E2 (The direction is the 1pin of product is at the upper left when you hold reel on the left hand and you pull out the tape on the right hand)

* Order quantity needs to be multiple of the minimum quantity.

Physical Dimension, Tape and Reel Information - continued

Package Name	VQFN36
--------------	--------

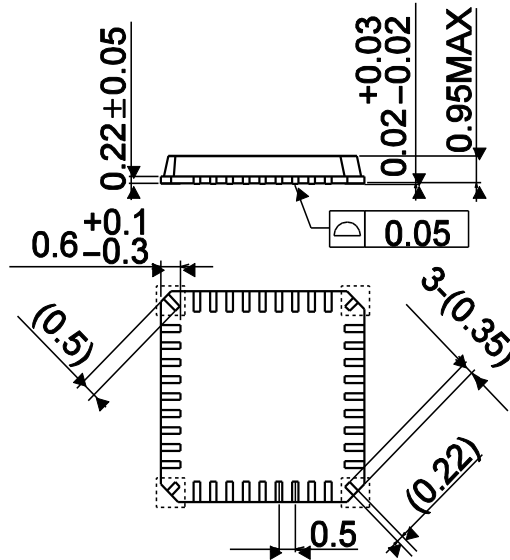
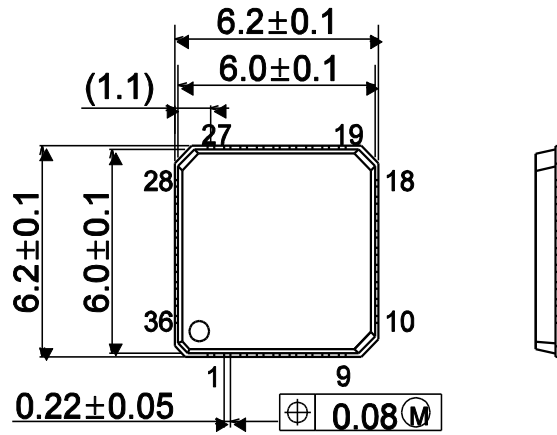

Notice :
Do not use the dotted line area
for soldering

(Unit : mm)

<Tape and Reel information>

Tape	Embossed carrier tape (with dry pack)
Quantity	2500pcs
Direction of feed	E2 (The direction is the 1pin of product is at the upper left when you hold reel on the left hand and you pull out the tape on the right hand)

* Order quantity needs to be multiple of the minimum quantity.

Revision History

Date	Revision	Changes
09.Dec.2015	001	New Release

Notice

Precaution on using ROHM Products

- Our Products are designed and manufactured for application in ordinary electronic equipments (such as AV equipment, OA equipment, telecommunication equipment, home electronic appliances, amusement equipment, etc.). If you intend to use our Products in devices requiring extremely high reliability (such as medical equipment ^(Note 1), transport equipment, traffic equipment, aircraft/spacecraft, nuclear power controllers, fuel controllers, car equipment including car accessories, safety devices, etc.) and whose malfunction or failure may cause loss of human life, bodily injury or serious damage to property ("Specific Applications"), please consult with the ROHM sales representative in advance. Unless otherwise agreed in writing by ROHM in advance, ROHM shall not be in any way responsible or liable for any damages, expenses or losses incurred by you or third parties arising from the use of any ROHM's Products for Specific Applications.

(Note1) Medical Equipment Classification of the Specific Applications

JAPAN	USA	EU	CHINA
CLASS III	CLASS III	CLASS II b	CLASS III
CLASS IV		CLASS III	

- ROHM designs and manufactures its Products subject to strict quality control system. However, semiconductor products can fail or malfunction at a certain rate. Please be sure to implement, at your own responsibilities, adequate safety measures including but not limited to fail-safe design against the physical injury, damage to any property, which a failure or malfunction of our Products may cause. The following are examples of safety measures:
 - Installation of protection circuits or other protective devices to improve system safety
 - Installation of redundant circuits to reduce the impact of single or multiple circuit failure
- Our Products are designed and manufactured for use under standard conditions and not under any special or extraordinary environments or conditions, as exemplified below. Accordingly, ROHM shall not be in any way responsible or liable for any damages, expenses or losses arising from the use of any ROHM's Products under any special or extraordinary environments or conditions. If you intend to use our Products under any special or extraordinary environments or conditions (as exemplified below), your independent verification and confirmation of product performance, reliability, etc. prior to use, must be necessary:
 - Use of our Products in any types of liquid, including water, oils, chemicals, and organic solvents
 - Use of our Products outdoors or in places where the Products are exposed to direct sunlight or dust
 - Use of our Products in places where the Products are exposed to sea wind or corrosive gases, including Cl₂, H₂S, NH₃, SO₂, and NO₂
 - Use of our Products in places where the Products are exposed to static electricity or electromagnetic waves
 - Use of our Products in proximity to heat-producing components, plastic cords, or other flammable items
 - Sealing or coating our Products with resin or other coating materials
 - Use of our Products without cleaning residue of flux (even if you use no-clean type fluxes, cleaning residue of flux is recommended); or Washing our Products by using water or water-soluble cleaning agents for cleaning residue after soldering
 - Use of the Products in places subject to dew condensation
- The Products are not subject to radiation-proof design.
- Please verify and confirm characteristics of the final or mounted products in using the Products.
- In particular, if a transient load (a large amount of load applied in a short period of time, such as pulse. is applied, confirmation of performance characteristics after on-board mounting is strongly recommended. Avoid applying power exceeding normal rated power; exceeding the power rating under steady-state loading condition may negatively affect product performance and reliability.
- De-rate Power Dissipation depending on ambient temperature. When used in sealed area, confirm that it is the use in the range that does not exceed the maximum junction temperature.
- Confirm that operation temperature is within the specified range described in the product specification.
- ROHM shall not be in any way responsible or liable for failure induced under deviant condition from what is defined in this document.

Precaution for Mounting / Circuit board design

- When a highly active halogenous (chlorine, bromine, etc.) flux is used, the residue of flux may negatively affect product performance and reliability.
- In principle, the reflow soldering method must be used on a surface-mount products, the flow soldering method must be used on a through hole mount products. If the flow soldering method is preferred on a surface-mount products, please consult with the ROHM representative in advance.

For details, please refer to ROHM Mounting specification

Precautions Regarding Application Examples and External Circuits

1. If change is made to the constant of an external circuit, please allow a sufficient margin considering variations of the characteristics of the Products and external components, including transient characteristics, as well as static characteristics.
2. You agree that application notes, reference designs, and associated data and information contained in this document are presented only as guidance for Products use. Therefore, in case you use such information, you are solely responsible for it and you must exercise your own independent verification and judgment in the use of such information contained in this document. ROHM shall not be in any way responsible or liable for any damages, expenses or losses incurred by you or third parties arising from the use of such information.

Precaution for Electrostatic

This Product is electrostatic sensitive product, which may be damaged due to electrostatic discharge. Please take proper caution in your manufacturing process and storage so that voltage exceeding the Products maximum rating will not be applied to Products. Please take special care under dry condition (e.g. Grounding of human body / equipment / solder iron, isolation from charged objects, setting of Ionizer, friction prevention and temperature / humidity control).

Precaution for Storage / Transportation

1. Product performance and soldered connections may deteriorate if the Products are stored in the places where:
 - [a] the Products are exposed to sea winds or corrosive gases, including Cl₂, H₂S, NH₃, SO₂, and NO₂
 - [b] the temperature or humidity exceeds those recommended by ROHM
 - [c] the Products are exposed to direct sunshine or condensation
 - [d] the Products are exposed to high Electrostatic
2. Even under ROHM recommended storage condition, solderability of products out of recommended storage time period may be degraded. It is strongly recommended to confirm solderability before using Products of which storage time is exceeding the recommended storage time period.
3. Store / transport cartons in the correct direction, which is indicated on a carton with a symbol. Otherwise bent leads may occur due to excessive stress applied when dropping of a carton.
4. Use Products within the specified time after opening a humidity barrier bag. Baking is required before using Products of which storage time is exceeding the recommended storage time period.

Precaution for Product Label

QR code printed on ROHM Products label is for ROHM's internal use only.

Precaution for Disposition

When disposing Products please dispose them properly using an authorized industry waste company.

Precaution for Foreign Exchange and Foreign Trade act

Since concerned goods might be fallen under listed items of export control prescribed by Foreign exchange and Foreign trade act, please consult with ROHM in case of export.

Precaution Regarding Intellectual Property Rights

1. All information and data including but not limited to application example contained in this document is for reference only. ROHM does not warrant that foregoing information or data will not infringe any intellectual property rights or any other rights of any third party regarding such information or data.
2. ROHM shall not have any obligations where the claims, actions or demands arising from the combination of the Products with other articles such as components, circuits, systems or external equipment (including software).
3. No license, expressly or implied, is granted hereby under any intellectual property rights or other rights of ROHM or any third parties with respect to the Products or the information contained in this document. Provided, however, that ROHM will not assert its intellectual property rights or other rights against you or your customers to the extent necessary to manufacture or sell products containing the Products, subject to the terms and conditions herein.

Other Precaution

1. This document may not be reprinted or reproduced, in whole or in part, without prior written consent of ROHM.
2. The Products may not be disassembled, converted, modified, reproduced or otherwise changed without prior written consent of ROHM.
3. In no event shall you use in any way whatsoever the Products and the related technical information contained in the Products or this document for any military purposes, including but not limited to, the development of mass-destruction weapons.
4. The proper names of companies or products described in this document are trademarks or registered trademarks of ROHM, its affiliated companies or third parties.

General Precaution

1. Before you use our Products, you are requested to carefully read this document and fully understand its contents. ROHM shall not be in any way responsible or liable for failure, malfunction or accident arising from the use of any ROHM's Products against warning, caution or note contained in this document.
2. All information contained in this document is current as of the issuing date and subject to change without any prior notice. Before purchasing or using ROHM's Products, please confirm the latest information with a ROHM sales representative.
3. The information contained in this document is provided on an "as is" basis and ROHM does not warrant that all information contained in this document is accurate and/or error-free. ROHM shall not be in any way responsible or liable for any damages, expenses or losses incurred by you or third parties resulting from inaccuracy or errors of or concerning such information.



BD6758KN - Web Page

[Distribution Inventory](#)

Part Number	BD6758KN
Package	VQFN36
Unit Quantity	2500
Minimum Package Quantity	2500
Packing Type	Taping
Constitution Materials List	inquiry
RoHS	Yes