



Bulletin 700S-CF

- IEC Industrial Safety Relay
- Positively Guided/Mechanically Linked Contacts as Per IEC 947-5-1 Annex L
- Third Party Certification By SUVA
- Red Cover and Mechanically Linked Contact Symbol on Front Face

Table Of Contents

Product Selection 197
 Specifications 199
 Approximate Dimensions 200

Type CF Safety Control Relays — 8-Pole AC Voltage



AC-1			AC-11 and AC-15							Connection Diagrams		Contacts		Catalog Number ①
I_e [A]			I_e [A]							Main Contacts	Auxiliary Contacts	N.O.	N.C.	
	40°C	60°C	24/48V	120V	240V	400V	500V	600V	690V					
Main Contacts	25	20	16	14	10	5	2.5	1.8	1			4	4	700S-CF440ⓄC
												5	3	700S-CF530ⓄC
Adder Deck Contacts	10	6	6	6	3	2	2	1.2	0.7			6	2	700S-CF620ⓄC

① All Cat. Nos. are factory-stocked.

Ⓞ AC Voltage Suffix Code

Voltage	12	24	32	36	42	48	100	100-110	110	120	127	200	200-220	208	208-240	220-230
50 Hz	R	K	V	W	X	Y	KP	—	D	P	S	KG	—	—	—	F
60 Hz	Q	J	—	V	—	X	—	KP	—	D	—	—	KG	H	L	—
50/60 Hz	—	KJ	—	—	—	KY	KP	—	KD	—	—	KG	—	—	—	—

Voltage	230	230-240	240	277	347	380	380-400	400	400-415	440	480	500	550	600
50 Hz	—	VA	T	—	—	—	N	—	G	B	—	M	C	—
60 Hz	—	—	A	T	I	E	—	—	—	N	B	—	—	C
50/60 Hz	KF	—	KA	—	—	—	—	KN	—	KB	—	—	—	—

① All Cat. Nos. are factory-stocked.

② See page 198 for coil voltage selection information.





Bulletin 700S-CF
Industrial Relays

Product Selection, Continued

Ordering Details

Type CF Control Relays — 8-Pole DC Voltage

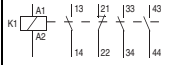

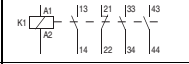
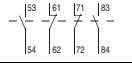
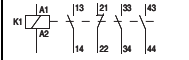
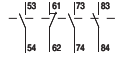
DC-1		DC-11 and DC-15							Connection Diagrams		Contacts		Catalog Number ① ②
I_e [A]		I_e [A]							Main Contacts	Auxiliary Contacts			
40°C	60°C	24/48V	120V	240V	400V	500V	600V	690V			N.O.	N.C.	
25	20	16	14	10	5	2.5	1.8	1			4	4	700S-CF440Z⊗C
											5	3	700S-CF530Z⊗C
											6	2	700S-CF620Z⊗C

- ① All Cat. Nos. are factory-stocked.
- ② See page 198 for coil voltage selection information.

⊗ **DC Voltage Suffix Code** ③

Voltage	9	12	24	36	48	60	64	72	80	110	115	125	220	230	250
Standard	R	Q	J	W	Y	Z	B	G	E	D	P	S	A	F	T
With diode suppressor \hat{a}	—	—	DJ	—	—	—	—	—	—	—	—	—	—	—	—

- ③ When ordering **DJ** coil with built-in surge suppression, remove **Z** from the Cat. No. Example: Cat. No. 700S-CF440Z⊗C becomes Catalog Number 700S-CF440DJC

Accessories

Safety Control Relays with	mm.	(inches)
Auxiliary contact block for side mounting 1- or 2-pole	a + 9	(a + 23/64)
Electronic Timing Module on coil terminal side	b + 24	(b + 15/16)
Mechanical Interlock on side of contactor	a + 9	(a + 23/64)
Interface Module on coil terminal side	b + 9	(b + 23/64)
Surge Suppressor on coil terminal side	b + 3	(b + 1/8)
Labeling with label sheet	+ 0	(+ 0)
marking tag sheet with clear cover	+ 0	(+ 0)
marking tag adapter for System Bul. 1492W	+ 5.5	(+ 7/32)

General

	Main Relay Cat. No. 700S-CF ②	Front Adder Deck Contacts	Side- mounted Contacts	
Contact Ratings — NEMA	A600, P600	A600, Q600		
Min. Contact Rating	Standard Gold	20V, 10 mA 12V, 8 mA		
Contact Ratings — IEC	24V	16 A	6 A	6 A
AC-15 (solenoids, contactors) at rated voltage	48V	16 A	6 A	6 A
IEC 947, EN 60947	120V	14 A	6 A	6 A
	240V	10 A	5 A	3 A
	400V	5 A	3 A	2 A
	480V/500V	2.5 A	1.6 A	2 A
	600V	1.8 A	1.2 A	1.2 A
	690V	1 A	1.0 A	0.7 A
AC-12 (Control of resistive loads) IEC 60947	40°C I_{th}	25 A	10 A	
	230 V	10 kW		
	400 V	17 kW		
	690 V	30 kW		
	60°C I_{th}	20 A	6 A	
	230V	8 kW		
	400V	14 kW		
	690V	24 kW		
DC-12 Switching DC Loads				
$L/R < 1ms$, Resistive Loads	24V	12 A	12 A	
IEC 60947	48V	9 A	9 A	
	110V	3.5 A	3.5 A	
	220V	0.55 A	0.55 A	
	440V	0.2 A	0.2 A	
DC-13 IEC 60947, Solenoids and contactors	24V	5 A	5 A	3 A
	48V	2 A	2 A	1.5 A
	125V	0.7 A	0.7 A	0.6 A
	220V	0.25 A	0.25 A	0.3 A
	440V	0.12 A	0.12 A	0.2 A
	660V	0.14 A	0.1 A	0.1 A
		Yes	Yes ①	

Location of welded N.O. contacts	State of N.C. Contacts if N.O. contact welds			
	Main	Front aux.	Left side aux.	Right side aux.
Main	Open	Open ①	Open	Open
Front aux.	Open	Open ①	Open	Open
Left side aux.	Open	Open ①	Open	Open
Right side aux.	Open	Open ①	Open	Open

- ① If the accessory is a pneumatic timer or latch, there is no positive guidance; the accessory contacts are independent.
- ② Defined in IEC 947-5-1 annex L. Positive guidance is a relationship between contacts of opposite types (i.e., N.O. and N.C.).

	Cat. No. 700S-CF	Aux./Pneumatic Timer Contact (Front-mounted)
Mechanical Life [Mil]	15	15
Electrical Life AC-15 (240V, 3 A) [Mil]	1.5	1.5
Weight AC Op. Mechanism [g]	390	—
Terminal Cross-Sections		
Terminal Type		
Terminal Size per IEC 947-1	2 x A4	2 x A4
Solid/Stranded 1 Conductor [mm²]	1.5...6	0.5...2.5
② 2 Conductor [mm²]	1.5...6	0.75...2.5
Max. Wire Size per UL/CSA [AWG]	16...10	18...14
Tightening Torque [lb.-in.]	8.9...22	8.9...13.3
Tightening Torque [N*m]	1...2.5	1...1.5

② For 16 or more strands, end ferrule is required

DC Switching Ratings for 700S-CF Main Poles in Series (Resistive Load at 60° C)			
	1 pole	2 poles	3 poles
24/48 V	25/20 A	25 A	25 A
125 V	6 A	25 A	25 A
220 V	1.5 A	8 A	25 A
440 V	0.4 A	1 A	3 A

Bulletin 700S-CF
Industrial Relays
Approximate Dimensions

Approximate Dimensions are shown in millimeters (inches). Approximate Dimensions are not intended for manufacturing purposes.

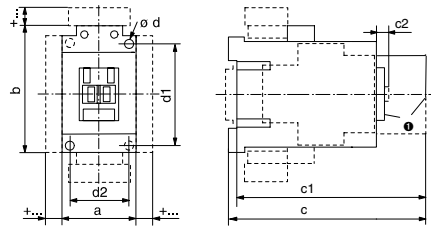

AC Safety Control Relays

a	b	c	c1	c2	Ød	d1	d2	Cat. No.
45 (1-25/32)	81 (3-3/16)	119.5 (4-3/4)	114.5 (4-43/64)	6 (1/4)	2 - 4.5 (2 - 3/16)	60 (2-23/64)	35 (1-25/64)	700S-CF

DC Safety Control Relays

a	b	c	c1	c2	Ød	d1	d2	Cat. No.
45 (1-25/32)	81 (3-3/16)	145.5 (5-49/64)	140.5 (5-37/64)	6 (1/4)	2 - 4.5 (2 - 3/16)	60 (2-23/64)	35 (1-25/64)	700S-CF

Mounting Positions

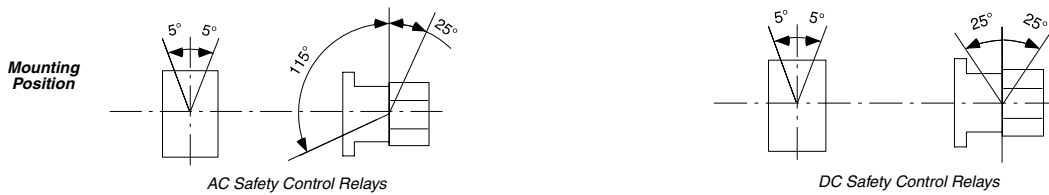

Safety Relay Circuit With 5 Safety Outputs

- Use for E-stop control. E-stop will work properly if any one fault occurs (a fault could be one welded contact or one undesired open connection such as a loose wire).
- High output switching capability and long contact life.
- Circuit complies with EN 954 categories 1, 2, 3, 4
- Prevents restart of the 5 safety outputs if there is a single fault anywhere in the system.

Use (3) 700S-CF relays and this diagram to construct the circuit, or contact your local Allen Bradley sales office for pre-assembled module

Basic Circuit

(1) Output Circuit (3 Relays, 9 Terminal Blocks)

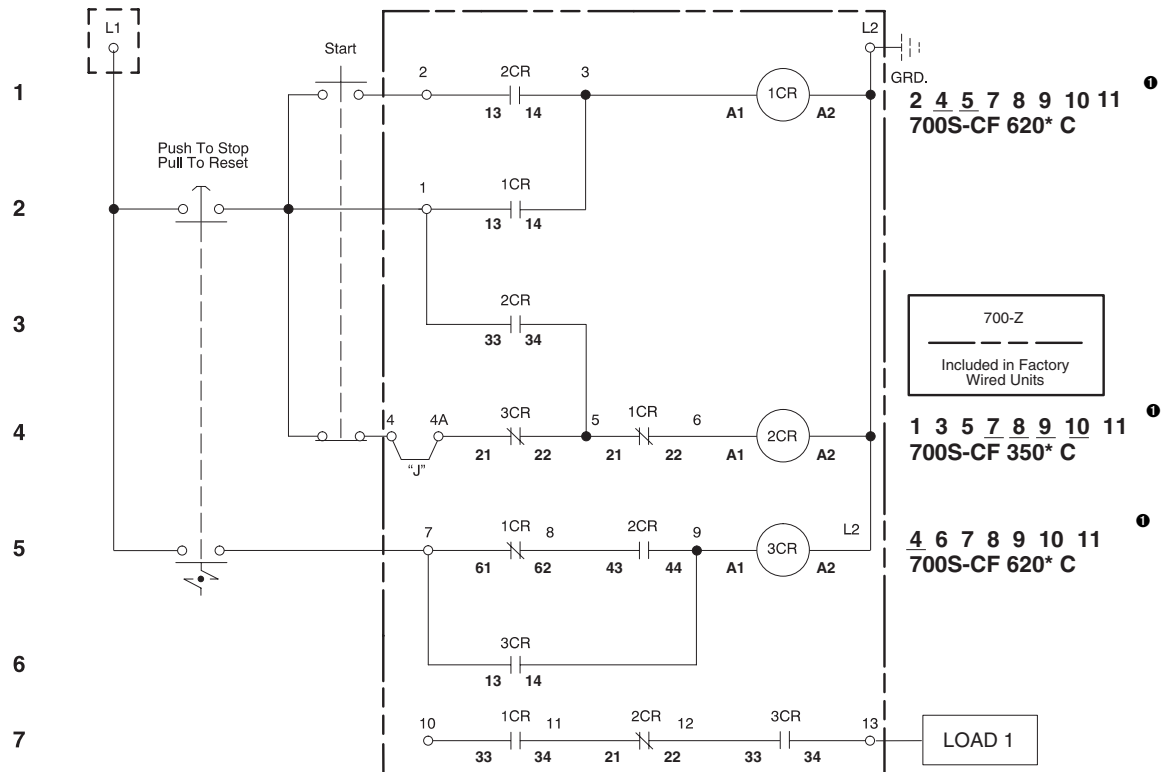

(5) Output Circuit (3 Relays, 17 Terminal Blocks)

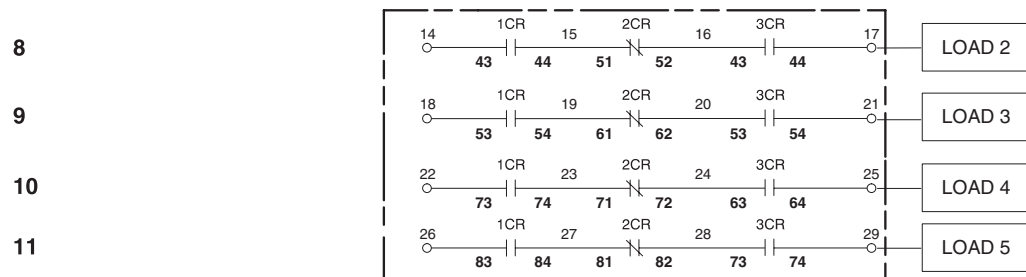

● Numbers shown are the line numbers where the contacts for this relay appear.