



HIGH-SPEED 2.5V

IDT70T653M

512K x 36 ASYNCHRONOUS DUAL-PORT STATIC RAM WITH 3.3V OR 2.5V INTERFACE

LEAD FINISH (SnPb) ARE IN EOL PROCESS - LAST TIME BUY EXPIRES JUNE 15, 2018

Features

- True Dual-Port memory cells which allow simultaneous access of the same memory location
High-speed access
Commercial: 10/12/15ns (max.)
Industrial: 12ns (max.)
RapidWrite Mode simplifies high-speed consecutive write cycles
Dual chip enables allow for depth expansion without external logic
IDT70T653M easily expands data bus width to 72 bits or more using the Busy Input when cascading more than one device
Busy input for port contention management
Interrupt Flags
Full on-chip hardware support of semaphore signaling between ports
Fully asynchronous operation from either port
Separate byte controls for multiplexed bus and bus matching compatibility
Sleep Mode Inputs on both ports
Single 2.5V (±100mV) power supply for core
LVTTTL-compatible, selectable 3.3V (±150mV)/2.5V (±100mV) power supply for I/Os and control signals on each port
Includes JTAG functionality
Available in a 256-ball Ball Grid Array
Industrial temperature range (-40°C to +85°C) is available for selected speeds
Green parts available, see ordering information

Functional Block Diagram

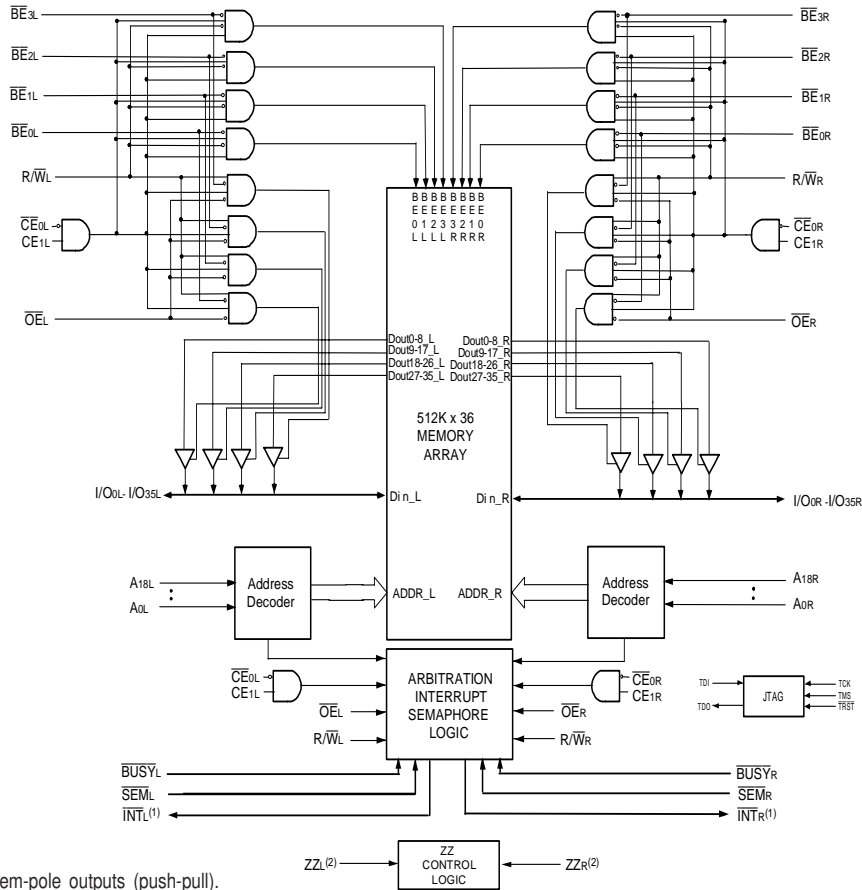

NOTES:

- 1. INT is non-tri-state totem-pole outputs (push-pull).
2. The sleep mode pin shuts off all dynamic inputs, except JTAG inputs, when asserted. OPTx, INTx and the sleep mode pins themselves (ZZx) are not affected during sleep mode.

5679 drw 01

DECEMBER 2017

## **Description**

The IDT70T653M is a high-speed 512K x 36 Asynchronous Dual-Port Static RAM. The IDT70T653M is designed to be used as a stand-alone 18874K-bit Dual-Port RAM. This device provides two independent ports with separate control, address, and I/O pins that permit independent, asynchronous access for reads or writes to any location in memory. An automatic power down feature controlled by the chip enables (either  $\overline{CE_0}$  or  $CE_1$ ) permit the on-chip circuitry of each port to enter a very low standby power mode.

The IDT70T653M has a RapidWrite Mode which allows the designer to perform back-to-back write operations without pulsing the  $\overline{R/\overline{W}}$  input each cycle. This is especially significant at the 10ns cycle time of the IDT70T653M, easing design considerations at these high performance levels.

The 70T653M can support an operating voltage of either 3.3V or 2.5V on one or both ports, controlled by the OPT pins. The power supply for the core of the device ( $V_{DD}$ ) is at 2.5V.

Pin Configuration<sup>(1,2,3)</sup>70T653M BC  
BC-256<sup>(4,5)</sup>256-Pin BGA  
Top View

A1	A2	A3	A4	A5	A6	A7	A8	A9	A10	A11	A12	A13	A14	A15	A16
NC	TDI	NC	A17L	A14L	A11L	A8L	$\overline{BE}_2L$	CE <sub>1L</sub>	$\overline{OE}_L$	$\overline{INT}_L$	A5L	A2L	A0L	NC	NC
B1	B2	B3	B4	B5	B6	B7	B8	B9	B10	B11	B12	B13	B14	B15	B16
I/O <sub>18L</sub>	NC	TDO	A18L	A15L	A12L	A9L	$\overline{BE}_3L$	$\overline{CE}_0L$	R/ $\overline{W}_L$	NC	A4L	A1L	NC	I/O <sub>17L</sub>	NC
C1	C2	C3	C4	C5	C6	C7	C8	C9	C10	C11	C12	C13	C14	C15	C16
I/O <sub>18R</sub>	I/O <sub>19L</sub>	VSS	A16L	A13L	A10L	A7L	$\overline{BE}_1L$	$\overline{BE}_0L$	$\overline{SEML}$	$\overline{BUSYL}$	A6L	A3L	OPT <sub>L</sub>	I/O <sub>17R</sub>	I/O <sub>16L</sub>
D1	D2	D3	D4	D5	D6	D7	D8	D9	D10	D11	D12	D13	D14	D15	D16
I/O <sub>20R</sub>	I/O <sub>19R</sub>	I/O <sub>20L</sub>	VDD	VDDQL	VDDQL	VDDQR	VDDQR	VDDQL	VDDQL	VDDQR	VDDQR	VDD	I/O <sub>15R</sub>	I/O <sub>15L</sub>	I/O <sub>16R</sub>
E1	E2	E3	E4	E5	E6	E7	E8	E9	E10	E11	E12	E13	E14	E15	E16
I/O <sub>21R</sub>	I/O <sub>21L</sub>	I/O <sub>22L</sub>	VDDQL	VDD	VDD	VSS	VSS	VSS	VSS	VDD	VDD	VDDQR	I/O <sub>13L</sub>	I/O <sub>14L</sub>	I/O <sub>14R</sub>
F1	F2	F3	F4	F5	F6	F7	F8	F9	F10	F11	F12	F13	F14	F15	F16
I/O <sub>23L</sub>	I/O <sub>22R</sub>	I/O <sub>23R</sub>	VDDQL	VDD	NC	VSS	VSS	VSS	VSS	VSS	VDD	VDDQR	I/O <sub>12R</sub>	I/O <sub>13R</sub>	I/O <sub>12L</sub>
G1	G2	G3	G4	G5	G6	G7	G8	G9	G10	G11	G12	G13	G14	G15	G16
I/O <sub>24R</sub>	I/O <sub>24L</sub>	I/O <sub>25L</sub>	VDDQR	VSS	VSS	VSS	VSS	VSS	VSS	VSS	VSS	VDDQL	I/O <sub>10L</sub>	I/O <sub>11L</sub>	I/O <sub>11R</sub>
H1	H2	H3	H4	H5	H6	H7	H8	H9	H10	H11	H12	H13	H14	H15	H16
I/O <sub>26L</sub>	I/O <sub>25R</sub>	I/O <sub>26R</sub>	VDDQR	VSS	VSS	VSS	VSS	VSS	VSS	VSS	VSS	VDDQL	I/O <sub>9R</sub>	I/O <sub>9L</sub>	I/O <sub>10R</sub>
J1	J2	J3	J4	J5	J6	J7	J8	J9	J10	J11	J12	J13	J14	J15	J16
I/O <sub>27L</sub>	I/O <sub>28R</sub>	I/O <sub>27R</sub>	VDDQL	ZZR	VSS	VSS	VSS	VSS	VSS	VSS	ZZL	VDDQR	I/O <sub>8R</sub>	I/O <sub>7R</sub>	I/O <sub>8L</sub>
K1	K2	K3	K4	K5	K6	K7	K8	K9	K10	K11	K12	K13	K14	K15	K16
I/O <sub>29R</sub>	I/O <sub>29L</sub>	I/O <sub>28L</sub>	VDDQL	VSS	VSS	VSS	VSS	VSS	VSS	VSS	VSS	VDDQR	I/O <sub>6R</sub>	I/O <sub>6L</sub>	I/O <sub>7L</sub>
L1	L2	L3	L4	L5	L6	L7	L8	L9	L10	L11	L12	L13	L14	L15	L16
I/O <sub>30L</sub>	I/O <sub>31R</sub>	I/O <sub>30R</sub>	VDDQR	VDD	NC	VSS	VSS	VSS	VSS	VSS	VDD	VDDQL	I/O <sub>5L</sub>	I/O <sub>4R</sub>	I/O <sub>5R</sub>
M1	M2	M3	M4	M5	M6	M7	M8	M9	M10	M11	M12	M13	M14	M15	M16
I/O <sub>32R</sub>	I/O <sub>32L</sub>	I/O <sub>31L</sub>	VDDQR	VDD	VDD	VSS	VSS	VSS	VSS	VDD	VDD	VDDQL	I/O <sub>3R</sub>	I/O <sub>3L</sub>	I/O <sub>4L</sub>
N1	N2	N3	N4	N5	N6	N7	N8	N9	N10	N11	N12	N13	N14	N15	N16
I/O <sub>33L</sub>	I/O <sub>34R</sub>	I/O <sub>33R</sub>	VDD	VDDQR	VDDQR	VDDQL	VDDQL	VDDQR	VDDQR	VDDQL	VDDQL	VDD	I/O <sub>2L</sub>	I/O <sub>1R</sub>	I/O <sub>2R</sub>
P1	P2	P3	P4	P5	P6	P7	P8	P9	P10	P11	P12	P13	P14	P15	P16
I/O <sub>35R</sub>	I/O <sub>34L</sub>	TMS	A16R	A13R	A10R	A7R	$\overline{BE}_1R$	$\overline{BE}_0R$	$\overline{SEMR}$	$\overline{BUSY}_R$	A6R	A3R	I/O <sub>0L</sub>	I/O <sub>0R</sub>	I/O <sub>1L</sub>
R1	R2	R3	R4	R5	R6	R7	R8	R9	R10	R11	R12	R13	R14	R15	R16
I/O <sub>35L</sub>	NC	$\overline{TRST}$	A18R	A15R	A12R	A9R	$\overline{BE}_3R$	$\overline{CE}_0R$	R/ $\overline{W}_R$	VSS	A4R	A1R	OPT <sub>R</sub>	NC	NC
T1	T2	T3	T4	T5	T6	T7	T8	T9	T10	T11	T12	T13	T14	T15	T16
NC	TCK	NC	A17R	A14R	A11R	A8R	$\overline{BE}_2R$	CE <sub>1R</sub>	$\overline{OE}_R$	$\overline{INT}_R$	A5R	A2R	A0R	NC	NC

5679 drw 02f

## NOTES:

1. All V<sub>DD</sub> pins must be connected to 2.5V power supply.
2. All V<sub>DDQ</sub> pins must be connected to appropriate power supply: 3.3V if OPT pin for that port is set to V<sub>DD</sub> (2.5V), and 2.5V if OPT pin for that port is set to V<sub>SS</sub> (0V).
3. All V<sub>SS</sub> pins must be connected to ground supply.
4. Package body is approximately 17mm x 17mm x 1.4mm, with 1.0mm ball-pitch.
5. This package code is used to reference the package diagram.

## Pin Names

Left Port	Right Port	Names
$\overline{CE}_{0L}$ , $CE_{1L}$	$\overline{CE}_{0R}$ , $CE_{1R}$	Chip Enables (Input)
$R\overline{W}_L$	$R\overline{W}_R$	Read/Write Enable (Input)
$\overline{OE}_L$	$\overline{OE}_R$	Output Enable (Input)
$A_{0L}$ - $A_{18L}$	$A_{0R}$ - $A_{18R}$	Address (Input)
$I/O_{0L}$ - $I/O_{35L}$	$I/O_{0R}$ - $I/O_{35R}$	Data Input/Output
$\overline{SEM}_L$	$\overline{SEM}_R$	Semaphore Enable (Input)
$\overline{INT}_L$	$\overline{INT}_R$	Interrupt Flag (Output)
$\overline{BUSY}_L$	$\overline{BUSY}_R$	Busy Input
$\overline{BE}_{0L}$ - $\overline{BE}_{3L}$	$\overline{BE}_{0R}$ - $\overline{BE}_{3R}$	Byte Enables (9-bit bytes) (Input)
$V_{DDQL}$	$V_{DDQR}$	Power (I/O Bus) (3.3V or 2.5V) <sup>(1)</sup> (Input)
$OPT_L$	$OPT_R$	Option for selecting $V_{DDQX}$ <sup>(1,2)</sup> (Input)
$ZZ_L$	$ZZ_R$	Sleep Mode Pin <sup>(3)</sup> (Input)
$V_{DD}$		Power (2.5V) <sup>(1)</sup> (Input)
$V_{SS}$		Ground (0V) (Input)
$TDI$		Test Data Input
$TDO$		Test Data Output
$TCK$		Test Logic Clock (10MHz) (Input)
$TMS$		Test Mode Select (Input)
$\overline{TRST}$		Reset (Initialize TAP Controller) (Input)

5679 tbl 01

### NOTES:

1.  $V_{DD}$ ,  $OPT_x$ , and  $V_{DDQX}$  must be set to appropriate operating levels prior to applying inputs on  $I/O_x$ .
2.  $OPT_x$  selects the operating voltage levels for the  $I/O$ s and controls on that port. If  $OPT_x$  is set to  $V_{DD}$  (2.5V), then that port's  $I/O$ s and controls will operate at 3.3V levels and  $V_{DDQX}$  must be supplied at 3.3V. If  $OPT_x$  is set to  $V_{SS}$  (0V), then that port's  $I/O$ s and controls will operate at 2.5V levels and  $V_{DDQX}$  must be supplied at 2.5V. The  $OPT$  pins are independent of one another—both ports can operate at 3.3V levels, both can operate at 2.5V levels, or either can operate at 3.3V with the other at 2.5V.
3. The sleep mode pin shuts off all dynamic inputs, except JTAG inputs, when asserted.  $OPT_x$ ,  $\overline{INT}_x$  and the sleep mode pins themselves ( $ZZ_x$ ) are not affected during sleep mode. It is recommended that boundary scan not be operated during sleep mode.

**Truth Table I—Read/Write and Enable Control<sup>(1,2)</sup>**

$\overline{OE}$	$\overline{SEM}$	$\overline{CE}_0$	$CE_1$	$\overline{BE}_3$	$\overline{BE}_2$	$\overline{BE}_1$	$\overline{BE}_0$	R/W	ZZ	Byte 3 I/O <sub>27-35</sub>	Byte 2 I/O <sub>18-26</sub>	Byte 1 I/O <sub>9-17</sub>	Byte 0 I/O <sub>0-8</sub>	MODE
X	H	H	X	X	X	X	X	X	L	High-Z	High-Z	High-Z	High-Z	Deselected—Power Down
X	H	X	L	X	X	X	X	X	L	High-Z	High-Z	High-Z	High-Z	Deselected—Power Down
X	H	L	H	H	H	H	H	X	L	High-Z	High-Z	High-Z	High-Z	All Bytes Deselected
X	H	L	H	H	H	H	L	L	L	High-Z	High-Z	High-Z	DIN	Write to Byte 0 Only
X	H	L	H	H	H	L	H	L	L	High-Z	High-Z	DIN	High-Z	Write to Byte 1 Only
X	H	L	H	H	L	H	H	L	L	High-Z	DIN	High-Z	High-Z	Write to Byte 2 Only
X	H	L	H	L	H	H	H	L	L	DIN	High-Z	High-Z	High-Z	Write to Byte 3 Only
X	H	L	H	H	H	L	L	L	L	High-Z	High-Z	DIN	DIN	Write to Lower 2 Bytes Only
X	H	L	H	L	L	H	H	L	L	DIN	DIN	High-Z	High-Z	Write to Upper 2 bytes Only
X	H	L	H	L	L	L	L	L	L	DIN	DIN	DIN	DIN	Write to All Bytes
L	H	L	H	H	H	H	L	H	L	High-Z	High-Z	High-Z	DOUT	Read Byte 0 Only
L	H	L	H	H	H	L	H	H	L	High-Z	High-Z	DOUT	High-Z	Read Byte 1 Only
L	H	L	H	H	L	H	H	H	L	High-Z	DOUT	High-Z	High-Z	Read Byte 2 Only
L	H	L	H	L	H	H	H	H	L	DOUT	High-Z	High-Z	High-Z	Read Byte 3 Only
L	H	L	H	H	H	L	L	H	L	High-Z	High-Z	DOUT	DOUT	Read Lower 2 Bytes Only
L	H	L	H	L	L	H	H	H	L	DOUT	DOUT	High-Z	High-Z	Read Upper 2 Bytes Only
L	H	L	H	L	L	L	L	H	L	DOUT	DOUT	DOUT	DOUT	Read All Bytes
H	H	L	H	L	L	L	L	X	L	High-Z	High-Z	High-Z	High-Z	Outputs Disabled
X	X	X	X	X	X	X	X	X	H	High-Z	High-Z	High-Z	High-Z	High-Z Sleep Mode

5679 tbl 02

**NOTES:**

- "H" =  $V_{IH}$ , "L" =  $V_{IL}$ , "X" = Don't Care.
- It is possible to read or write any combination of bytes during a given access. A few representative samples have been illustrated here.

**Truth Table II – Semaphore Read/Write Control<sup>(1)</sup>**

Inputs <sup>(1)</sup>								Outputs		Mode
$\overline{CE}^{(2)}$	R/W	$\overline{OE}$	$\overline{BE}_3$	$\overline{BE}_2$	$\overline{BE}_1$	$\overline{BE}_0$	$\overline{SEM}$	I/O <sub>1-8</sub> , I/O <sub>18-26</sub>	I/O <sub>0</sub>	
H	H	L	X	L	X	L	L	DATA <sub>OUT</sub>	DATA <sub>OUT</sub>	Read Data in Semaphore Flag <sup>(3)</sup>
H	↑	X	X	X	X	L	L	X	DATA <sub>IN</sub>	Write I/O <sub>0</sub> into Semaphore Flag
L	X	X	X	X	X	X	L	—	—	Not Allowed

5679 tbl 03

**NOTES:**

- There are eight semaphore flags written to I/O<sub>0</sub> and read from the I/Os (I/O<sub>0</sub>-I/O<sub>08</sub> and I/O<sub>18</sub>-I/O<sub>26</sub>). These eight semaphore flags are addressed by A<sub>0</sub>-A<sub>2</sub>.
- $\overline{CE} = L$  occurs when  $\overline{CE}_0 = V_{IL}$  and  $CE_1 = V_{IH}$ .  $\overline{CE} = H$  when  $\overline{CE}_0 = V_{IH}$  and/or  $CE_1 = V_{IL}$ .
- Each byte is controlled by the respective  $\overline{BE}_n$ . To read data  $\overline{BE}_n = V_{IL}$ .

## Recommended Operating Temperature and Supply Voltage<sup>(1)</sup>

Grade	Ambient Temperature	GND	V <sub>DD</sub>
Commercial	0°C to +70°C	0V	2.5V ± 100mV
Industrial	-40°C to +85°C	0V	2.5V ± 100mV

5679 tbl 04

### NOTE:

1. This is the parameter TA. This is the "instant on" case temperature.

## Capacitance<sup>(1)</sup>

(TA = +25°C, F = 1.0MHz) PQFP ONLY

Symbol	Parameter	Conditions	Max.	Unit
C <sub>IN</sub>	Input Capacitance	V <sub>IN</sub> = 0V	15	pF
C <sub>OUT</sub> <sup>(2)</sup>	Output Capacitance	V <sub>OUT</sub> = 0V	10.5	pF

5679 tbl 08

### NOTES:

1. These parameters are determined by device characterization, but are not production tested.
2. C<sub>OUT</sub> also references C<sub>I/O</sub>.

## Absolute Maximum Ratings<sup>(1)</sup>

Symbol	Rating	Commercial & Industrial	Unit
V <sub>TERM</sub> (V <sub>DD</sub> )	V <sub>DD</sub> Terminal Voltage with Respect to GND	-0.5 to 3.6	V
V <sub>TERM</sub> <sup>(2)</sup> (V <sub>DDQ</sub> )	V <sub>DDQ</sub> Terminal Voltage with Respect to GND	-0.3 to V <sub>DDQ</sub> + 0.3	V
V <sub>TERM</sub> <sup>(2)</sup> (INPUTS and I/O's)	Input and I/O Terminal Voltage with Respect to GND	-0.3 to V <sub>DDQ</sub> + 0.3	V
T <sub>BIAS</sub> <sup>(3)</sup>	Temperature Under Bias	-55 to +125	°C
T <sub>STG</sub>	Storage Temperature	-65 to +150	°C
T <sub>JN</sub>	Junction Temperature	+150	°C
I <sub>OUT</sub> (For V <sub>DDQ</sub> = 3.3V)	DC Output Current	50	mA
I <sub>OUT</sub> (For V <sub>DDQ</sub> = 2.5V)	DC Output Current	40	mA

5679 tbl 07

### NOTES:

1. Stresses greater than those listed under ABSOLUTE MAXIMUM RATINGS may cause permanent damage to the device. This is a stress rating only and functional operation of the device at these or any other conditions above those indicated in the operational sections of this specification is not implied. Exposure to absolute maximum rating conditions for extended periods may affect reliability.
2. This is a steady-state DC parameter that applies after the power supply has reached its nominal operating value. Power sequencing is not necessary; however, the voltage on any Input or I/O pin cannot exceed V<sub>DDQ</sub> during power supply ramp up.
3. Ambient Temperature under DC Bias. No AC Conditions. Chip Deselected.

## Recommended DC Operating Conditions with V<sub>DDQ</sub> at 2.5V

Symbol	Parameter	Min.	Typ.	Max.	Unit
V <sub>DD</sub>	Core Supply Voltage	2.4	2.5	2.6	V
V <sub>DDQ</sub>	I/O Supply Voltage <sup>(3)</sup>	2.4	2.5	2.6	V
V <sub>SS</sub>	Ground	0	0	0	V
V <sub>IH</sub>	Input High Voltage (Address, Control & Data I/O Inputs) <sup>(3)</sup>	1.7	---	V <sub>DDQ</sub> + 100mV <sup>(2)</sup>	V
V <sub>IH</sub>	Input High Voltage - JTAG	1.7	---	V <sub>DD</sub> + 100mV <sup>(2)</sup>	V
V <sub>IH</sub>	Input High Voltage - ZZ, OPT	V <sub>DD</sub> - 0.2V	---	V <sub>DD</sub> + 100mV <sup>(2)</sup>	V
V <sub>IL</sub>	Input Low Voltage	-0.3 <sup>(1)</sup>	---	0.7	V
V <sub>IL</sub>	Input Low Voltage - ZZ, OPT	-0.3 <sup>(1)</sup>	---	0.2	V

5679 tbl 05

### NOTES:

1. V<sub>IL</sub> (min.) = -1.0V for pulse width less than trc/2 or 5ns, whichever is less.
2. V<sub>IH</sub> (max.) = V<sub>DDQ</sub> + 1.0V for pulse width less than trc/2 or 5ns, whichever is less.
3. To select operation at 2.5V levels on the I/Os and controls of a given port, the OPT pin for that port must be set to V<sub>SS</sub>(0V), and V<sub>DDQX</sub> for that port must be supplied as indicated above.

## Recommended DC Operating Conditions with V<sub>DDQ</sub> at 3.3V

Symbol	Parameter	Min.	Typ.	Max.	Unit
V <sub>DD</sub>	Core Supply Voltage	2.4	2.5	2.6	V
V <sub>DDQ</sub>	I/O Supply Voltage <sup>(3)</sup>	3.15	3.3	3.45	V
V <sub>SS</sub>	Ground	0	0	0	V
V <sub>IH</sub>	Input High Voltage (Address, Control & Data I/O Inputs) <sup>(3)</sup>	2.0	---	V <sub>DDQ</sub> + 150mV <sup>(2)</sup>	V
V <sub>IH</sub>	Input High Voltage - JTAG	1.7	---	V <sub>DD</sub> + 100mV <sup>(2)</sup>	V
V <sub>IH</sub>	Input High Voltage - ZZ, OPT	V <sub>DD</sub> - 0.2V	---	V <sub>DD</sub> + 100mV <sup>(2)</sup>	V
V <sub>IL</sub>	Input Low Voltage	-0.3 <sup>(1)</sup>	---	0.8	V
V <sub>IL</sub>	Input Low Voltage - ZZ, OPT	-0.3 <sup>(1)</sup>	---	0.2	V

5679 tbl 06

### NOTES:

1. V<sub>IL</sub> (min.) = -1.0V for pulse width less than trc/2 or 5ns, whichever is less.
2. V<sub>IH</sub> (max.) = V<sub>DDQ</sub> + 1.0V for pulse width less than trc/2 or 5ns, whichever is less.
3. To select operation at 3.3V levels on the I/Os and controls of a given port, the OPT pin for that port must be set to V<sub>DD</sub> (2.5V), and V<sub>DDQX</sub> for that port must be supplied as indicated above.

## DC Electrical Characteristics Over the Operating Temperature and Supply Voltage Range ( $V_{DD} = 2.5V \pm 100mV$ )

Symbol	Parameter	Test Conditions	70T653M		Unit
			Min.	Max.	
$ I_{L} $	Input Leakage Current <sup>(1)</sup>	$V_{DDQ} = \text{Max.}, V_{IN} = 0V \text{ to } V_{DDQ}$	—	10	$\mu A$
$ I_{L} $	JTAG & ZZ Input Leakage Current <sup>(1,2)</sup>	$V_{DD} = \text{Max.}, V_{IN} = 0V \text{ to } V_{DD}$	—	$\pm 60$	$\mu A$
$ I_{L} $	Output Leakage Current <sup>(1,3)</sup>	$\overline{CE}_0 = V_{IH} \text{ or } CE_1 = V_{IL}, V_{OUT} = 0V \text{ to } V_{DDQ}$	—	10	$\mu A$
$V_{OL} (3.3V)$	Output Low Voltage <sup>(1)</sup>	$I_{OL} = +4mA, V_{DDQ} = \text{Min.}$	—	0.4	V
$V_{OH} (3.3V)$	Output High Voltage <sup>(1)</sup>	$I_{OH} = -4mA, V_{DDQ} = \text{Min.}$	2.4	—	V
$V_{OL} (2.5V)$	Output Low Voltage <sup>(1)</sup>	$I_{OL} = +2mA, V_{DDQ} = \text{Min.}$	—	0.4	V
$V_{OH} (2.5V)$	Output High Voltage <sup>(1)</sup>	$I_{OH} = -2mA, V_{DDQ} = \text{Min.}$	2.0	—	V

### NOTES:

- $V_{DDQ}$  is selectable (3.3V/2.5V) via OPT pins. Refer to page 6 for details.
- Applicable only for TMS, TDI and  $\overline{TRST}$  inputs.
- Outputs tested in tri-state mode.

5679 tbl 09

## DC Electrical Characteristics Over the Operating Temperature and Supply Voltage Range<sup>(3)</sup> ( $V_{DD} = 2.5V \pm 100mV$ )

Symbol	Parameter	Test Condition	Version	70T653MS10 Com'1 Only		70T653MS12 Com'1 & Ind		70T653MS15 Com'1 Only		Unit	
				Typ. <sup>(4)</sup>	Max.	Typ. <sup>(4)</sup>	Max.	Typ. <sup>(4)</sup>	Max.		
$I_{DD}$	Dynamic Operating Current (Both Ports Active)	$\overline{CE}_L$ and $\overline{CE}_R = V_{IL}$ , Outputs Disabled $f = f_{MAX}^{(1)}$	COM'L	S	600	810	600	710	450	600	mA
			IND	S	—	—	600	790	—	—	
$ISB1^{(6)}$	Standby Current (Both Ports - TTL Level Inputs)	$\overline{CE}_L = \overline{CE}_R = V_{IH}$ $f = f_{MAX}^{(1)}$	COM'L	S	180	240	150	210	120	170	mA
			IND	S	—	—	150	260	—	—	
$ISB2^{(6)}$	Standby Current (One Port - TTL Level Inputs)	$\overline{CE}^*A^* = V_{IL}$ and $\overline{CE}^*B^* = V_{IH}^{(5)}$ Active Port Outputs Disabled, $f = f_{MAX}^{(1)}$	COM'L	S	400	530	360	460	300	400	mA
			IND	S	—	—	360	510	—	—	
$ISB3$	Full Standby Current (Both Ports - CMOS Level Inputs)	Both Ports $\overline{CE}_L$ and $\overline{CE}_R \geq V_{DDQ} - 0.2V$ , $V_{IN} \geq V_{DDQ} - 0.2V$ or $V_{IN} \leq 0.2V$ , $f = 0^{(2)}$	COM'L	S	4	20	4	20	4	20	mA
			IND	S	—	—	4	40	—	—	
$ISB4^{(6)}$	Full Standby Current (One Port - CMOS Level Inputs)	$\overline{CE}^*A^* \leq 0.2V$ and $\overline{CE}^*B^* \geq V_{DDQ} - 0.2V^{(5)}$ $V_{IN} \geq V_{DDQ} - 0.2V$ or $V_{IN} \leq 0.2V$ , Active Port, Outputs Disabled, $f = f_{MAX}^{(1)}$	COM'L	S	400	530	—	460	300	400	mA
			IND	S	—	—	360	510	—	—	
$I_{ZZ}$	Sleep Mode Current (Both Ports - TTL Level Inputs)	$ZZ_L = ZZ_R = V_{IH}$ $f = f_{MAX}^{(1)}$	COM'L	S	4	20	4	20	4	20	mA
			IND	S	—	—	4	40	—	—	

### NOTES:

- At  $f = f_{MAX}$ , address and control lines (except Output Enable) are cycling at the maximum frequency read cycle of  $1/t_{RC}$ , using "AC TEST CONDITIONS" at input levels of GND to 3.3V.
- $f = 0$  means no address or control lines change. Applies only to input at CMOS level standby.
- Port "A" may be either left or right port. Port "B" is the opposite from port "A".
- $V_{DD} = 3.3V$ ,  $T_A = 25^\circ C$  for Typ, and are not production tested.  $I_{DD}(f=0) = 200mA$  (Typ).
- $\overline{CE}_X = V_{IL}$  means  $\overline{CE}_{0X} = V_{IL}$  and  $CE_{1X} = V_{IH}$   
 $\overline{CE}_X = V_{IH}$  means  $\overline{CE}_{0X} = V_{IH}$  or  $CE_{1X} = V_{IL}$   
 $\overline{CE}_X \leq 0.2V$  means  $\overline{CE}_{0X} \leq 0.2V$  and  $CE_{1X} \geq V_{DDQ} - 0.2V$   
 $\overline{CE}_X \geq V_{DDQ} - 0.2V$  means  $\overline{CE}_{0X} \geq V_{DDQ} - 0.2V$  or  $CE_{1X} \leq 0.2V$ .  
 "X" represents "L" for left port or "R" for right port.
- $ISB1$ ,  $ISB2$  and  $ISB4$  will all reach full standby levels ( $ISB3$ ) on the appropriate port(s) if  $ZZ_L$  and /or  $ZZ_R = V_{IH}$ .

5679 tbl 10

### AC Test Conditions (V<sub>DDQ</sub> - 3.3V/2.5V)

Input Pulse Levels	GND to 3.0V / GND to 2.4V
Input Rise/Fall Times	2ns Max.
Input Timing Reference Levels	1.5V/1.25V
Output Reference Levels	1.5V/1.25V
Output Load	Figure 1

5679 tbl 11

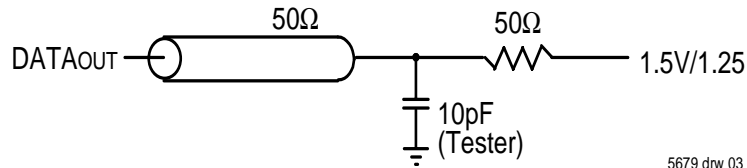

5679 drw 03

Figure 1. AC Output Test load.

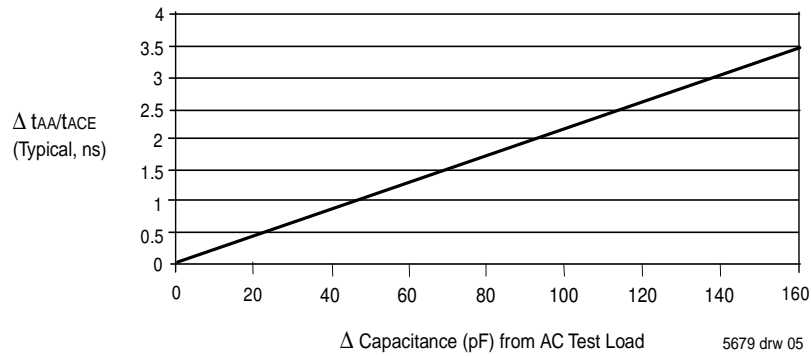

5679 drw 05

Figure 3. Typical Output Derating (Lumped Capacitive Load).

## AC Electrical Characteristics Over the Operating Temperature and Supply Voltage Range<sup>(4)</sup>

Symbol	Parameter	70T653MS10 Com'l Only		70T653MS12 Com'l & Ind		70T653MS15 Com'l Only		Unit
		Min.	Max.	Min.	Max.	Min.	Max.	
<b>READ CYCLE</b>								
t <sub>RC</sub>	Read Cycle Time	10	—	12	—	15	—	ns
t <sub>AA</sub>	Address Access Time	—	10	—	12	—	15	ns
t <sub>ACE</sub>	Chip Enable Access Time <sup>(3)</sup>	—	10	—	12	—	15	ns
t <sub>ABE</sub>	Byte Enable Access Time <sup>(3)</sup>	—	5	—	6	—	7	ns
t <sub>AOE</sub>	Output Enable Access Time	—	5	—	6	—	7	ns
t <sub>OH</sub>	Output Hold from Address Change	3	—	3	—	3	—	ns
t <sub>LZ</sub>	Output Low-Z Time Chip Enable and Semaphore <sup>(1,2)</sup>	3	—	3	—	3	—	ns
t <sub>LZOB</sub>	Output Low-Z Time Output Enable and Byte Enable <sup>(1,2)</sup>	0	—	0	—	0	—	ns
t <sub>HZ</sub>	Output High-Z Time <sup>(1,2)</sup>	0	4	0	6	0	8	ns
t <sub>PU</sub>	Chip Enable to Power Up Time <sup>(2)</sup>	0	—	0	—	0	—	ns
t <sub>PD</sub>	Chip Disable to Power Down Time <sup>(2)</sup>	—	8	—	8	—	12	ns
t <sub>SOP</sub>	Semaphore Flag Update Pulse ( $\overline{OE}$ or $\overline{SEM}$ )	—	4	—	6	—	8	ns
t <sub>SAA</sub>	Semaphore Address Access Time	2	10	2	12	2	15	ns
t <sub>SOE</sub>	Semaphore Output Enable Access Time	—	5	—	6	—	7	ns

5679 tbl 12

## AC Electrical Characteristics Over the Operating Temperature and Supply Voltage Range<sup>(4)</sup>

Symbol	Parameter	70T653MS10 Com'l Only		70T653MS12 Com'l & Ind		70T653MS15 Com'l Only		Unit
		Min.	Max.	Min.	Max.	Min.	Max.	
<b>WRITE CYCLE</b>								
t <sub>WC</sub>	Write Cycle Time	10	—	12	—	15	—	ns
t <sub>EW</sub>	Chip Enable to End-of-Write <sup>(3)</sup>	7	—	9	—	12	—	ns
t <sub>AW</sub>	Address Valid to End-of-Write	7	—	9	—	12	—	ns
t <sub>AS</sub>	Address Set-up Time <sup>(3)</sup>	0	—	0	—	0	—	ns
t <sub>WP</sub>	Write Pulse Width	7	—	9	—	12	—	ns
t <sub>WR</sub>	Write Recovery Time	0	—	0	—	0	—	ns
t <sub>DW</sub>	Data Valid to End-of-Write	5	—	7	—	10	—	ns
t <sub>DH</sub>	Data Hold Time	0	—	0	—	0	—	ns
t <sub>WZ</sub>	Write Enable to Output in High-Z <sup>(1,2)</sup>	—	4	—	6	—	8	ns
t <sub>OW</sub>	Output Active from End-of-Write <sup>(1,2)</sup>	3	—	3	—	3	—	ns
t <sub>SWRD</sub>	$\overline{SEM}$ Flag Write to Read Time	5	—	5	—	5	—	ns
t <sub>SPS</sub>	$\overline{SEM}$ Flag Contention Window	5	—	5	—	5	—	ns

5679 tbl 13

### NOTES:

1. Transition is measured 0mV from Low or High-impedance voltage with Output Test Load (Figure 1).
2. This parameter is guaranteed by device characterization, but is not production tested.
3. To access RAM,  $\overline{CE} = V_{IL}$  and  $\overline{SEM} = V_{IH}$ . To access semaphore,  $\overline{CE} = V_{IH}$  and  $\overline{SEM} = V_{IL}$ . Either condition must be valid for the entire t<sub>ew</sub> time.  $\overline{CE} = V_{IL}$  when  $\overline{CE}_0 = V_{IL}$  and  $\overline{CE}_1 = V_{IH}$ .  $\overline{CE} = V_{IH}$  when  $\overline{CE}_0 = V_{IH}$  and/or  $\overline{CE}_1 = V_{IL}$ .
4. These values are valid regardless of the power supply level selected for I/O and control signals (3.3V/2.5V). See page 6 for details.

### Waveform of Read Cycles<sup>(4)</sup>

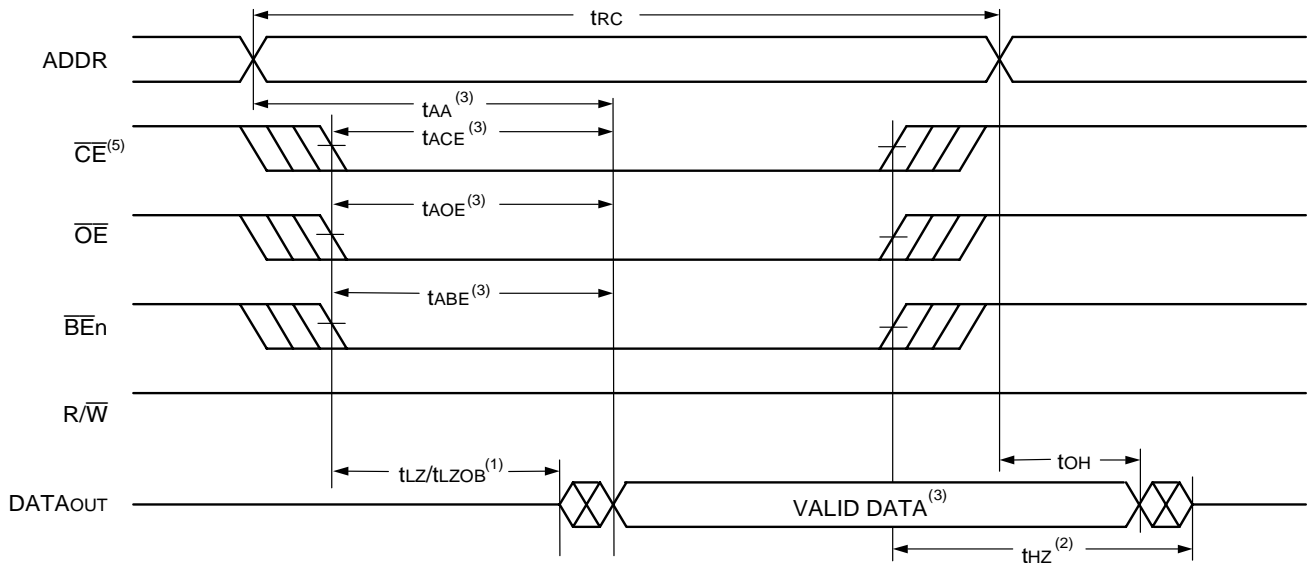

5679 drw 06

**NOTES:**

1. Timing depends on which signal is asserted last,  $\overline{OE}$ ,  $\overline{CE}$  or  $\overline{BEn}$ .
2. Timing depends on which signal is de-asserted first  $\overline{CE}$ ,  $\overline{OE}$  or  $\overline{BEn}$ .
3. Start of valid data depends on which timing becomes effective last  $t_{AOE}$ ,  $t_{ACE}$ ,  $t_{AA}$  or  $t_{ABE}$ .
4.  $\overline{SEM} = V_{IH}$ .
5.  $\overline{CE} = L$  occurs when  $\overline{CE}_0 = V_{IL}$  and  $CE_1 = V_{IH}$ .  $\overline{CE} = H$  when  $\overline{CE}_0 = V_{IH}$  and/or  $CE_1 = V_{IL}$ .

### Timing of Power-Up Power-Down

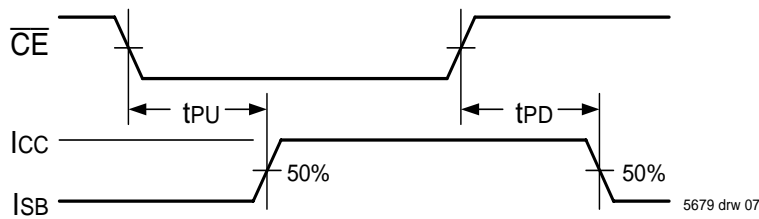

5679 drw 07

## Timing Waveform of Write Cycle No. 1, $R/\overline{W}$ Controlled Timing<sup>(1,5,8)</sup>

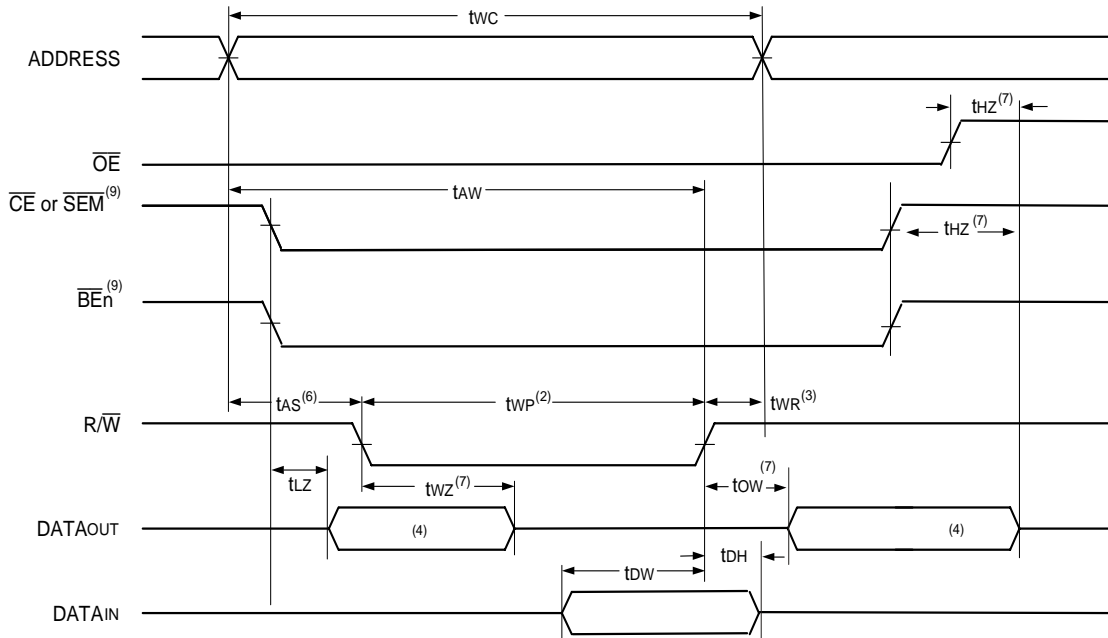

5679 drw 10

## Timing Waveform of Write Cycle No. 2, $\overline{CE}$ Controlled Timing<sup>(1,5,8)</sup>

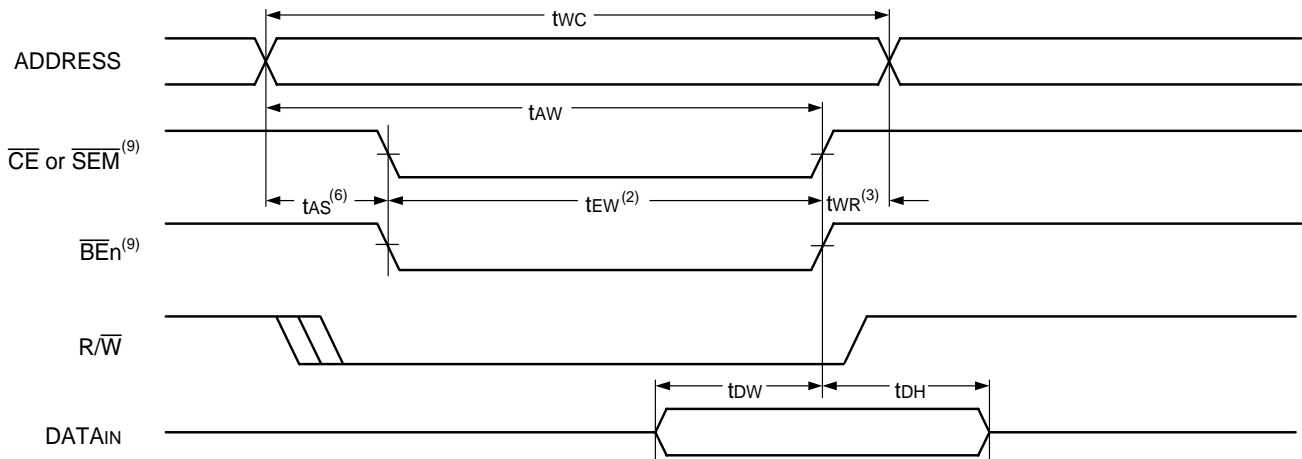

5679 drw 11

### NOTES:

- $R/\overline{W}$  or  $\overline{CE}$  or  $\overline{BEn}$  =  $V_{IH}$  during all address transitions for Write Cycles 1 and 2.
- A write occurs during the overlap ( $t_{EW}$  or  $t_{WP}$ ) of a  $\overline{CE}$  =  $V_{IL}$ ,  $\overline{BEn}$  =  $V_{IL}$ , and a  $R/\overline{W}$  =  $V_{IL}$  for memory array writing cycle.
- $t_{WR}$  is measured from the earlier of  $\overline{CE}$ ,  $\overline{BEn}$  or  $R/\overline{W}$  (or  $\overline{SEM}$  or  $R/\overline{W}$ ) going HIGH to the end of write cycle.
- During this period, the I/O pins are in the output state and input signals must not be applied.
- If the  $\overline{CE}$  or  $\overline{SEM}$  =  $V_{IL}$  transition occurs simultaneously with or after the  $R/\overline{W}$  =  $V_{IL}$  transition, the outputs remain in the High-impedance state.
- Timing depends on which enable signal is asserted last,  $\overline{CE}$  or  $R/\overline{W}$ .
- This parameter is guaranteed by device characterization, but is not production tested. Transition is measured 0mV from steady state with the Output Test Load (Figure 1).
- If  $\overline{OE}$  =  $V_{IL}$  during  $R/\overline{W}$  controlled write cycle, the write pulse width must be the larger of  $t_{WP}$  or ( $t_{WZ} + t_{DW}$ ) to allow the I/O drivers to turn off and data to be placed on the bus for the required  $t_{DW}$ . If  $\overline{OE}$  =  $V_{IH}$  during an  $R/\overline{W}$  controlled write cycle, this requirement does not apply and the write pulse can be as short as the specified  $t_{WP}$ .
- To access RAM,  $\overline{CE}$  =  $V_{IL}$  and  $\overline{SEM}$  =  $V_{IH}$ . To access semaphore,  $\overline{CE}$  =  $V_{IH}$  and  $\overline{SEM}$  =  $V_{IL}$ .  $t_{EW}$  must be met for either condition.  $\overline{CE}$  =  $V_{IL}$  when  $\overline{CE}_0$  =  $V_{IL}$  and  $CE_1$  =  $V_{IH}$ .  $\overline{CE}$  =  $V_{IH}$  when  $\overline{CE}_0$  =  $V_{IH}$  and/or  $CE_1$  =  $V_{IL}$ .

## RapidWrite Mode Write Cycle

Unlike other vendors' Asynchronous Random Access Memories, the IDT70T653M is capable of performing multiple back-to-back write operations without having to pulse the  $\overline{R/\overline{W}}$ ,  $\overline{CE}$ , or  $\overline{BEn}$  signals high during address transitions. This RapidWrite Mode functionality allows the system designer to achieve optimum back-to-back write cycle performance without the difficult task of generating narrow reset pulses every cycle, simplifying system design and reducing time to market.

During this new RapidWrite Mode, the end of the write cycle is now defined by the ending address transition, instead of the  $\overline{R/\overline{W}}$  or  $\overline{CE}$  or  $\overline{BEn}$  transition to the inactive state.  $\overline{R/\overline{W}}$ ,  $\overline{CE}$ , and  $\overline{BEn}$  can be held active throughout the address transition between write cycles. Care must be taken to still meet the Write Cycle time ( $t_{wc}$ ), the time in which the

Address inputs must be stable. Input data setup and hold times ( $t_{dW}$  and  $t_{dH}$ ) will now be referenced to the ending address transition. In this RapidWrite Mode the I/O will remain in the Input mode for the duration of the operations due to  $\overline{R/\overline{W}}$  being held low. All standard Write Cycle specifications must be adhered to. However,  $t_{AS}$  and  $t_{WR}$  are only applicable when switching between read and write operations. Also, there are two additional conditions on the Address Inputs that must also be met to ensure correct address controlled writes. These specifications, the Allowable Address Skew ( $t_{AAS}$ ) and the Address Rise/Fall time ( $t_{ARF}$ ), must be met to use the RapidWrite Mode. If these conditions are not met there is the potential for inadvertent write operations at random intermediate locations as the device transitions between the desired write addresses.

## Timing Waveform of Write Cycle No. 3, RapidWrite Mode Write Cycle<sup>(1,3)</sup>

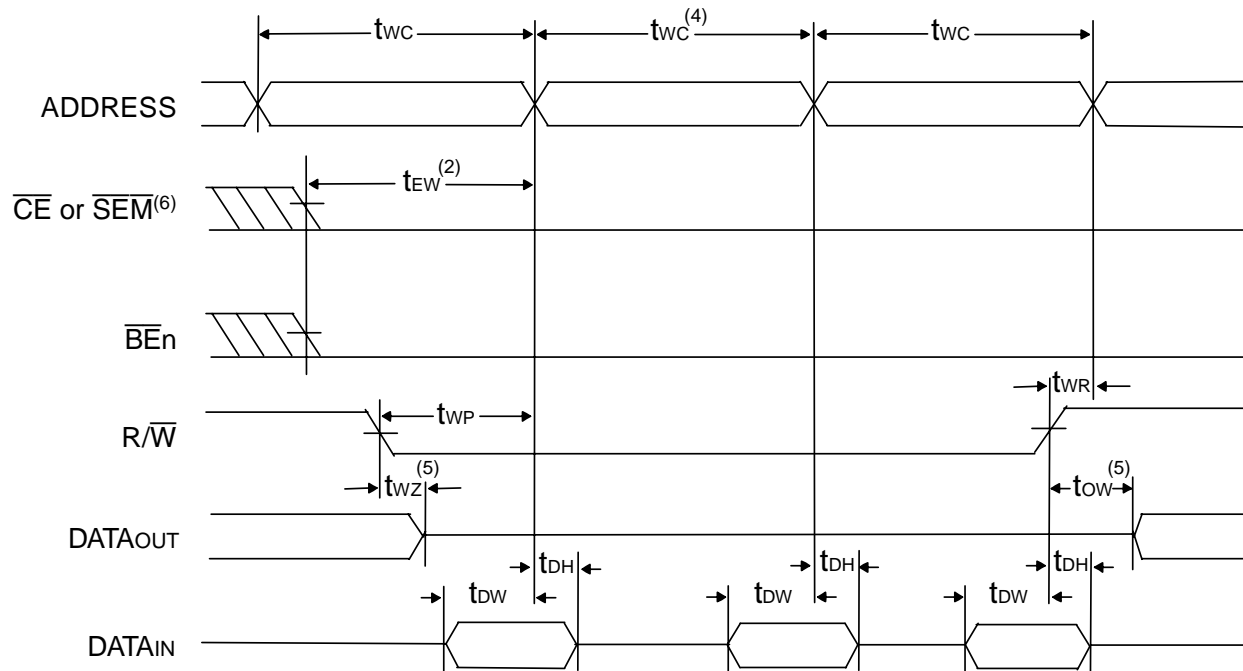

5679 drw 08

### NOTES:

- $\overline{OE} = V_{IL}$  for this timing waveform as shown.  $\overline{OE}$  may equal  $V_{IH}$  with same write functionality; I/O would then always be in High-Z state.
- A write occurs during the overlap ( $t_{EW}$  or  $t_{WP}$ ) of a  $\overline{CE} = V_{IL}$ ,  $\overline{BEn} = V_{IL}$ , and a  $\overline{R/\overline{W}} = V_{IL}$  for memory array writing cycle. The last transition LOW of  $\overline{CE}$ ,  $\overline{BEn}$ , and  $\overline{R/\overline{W}}$  initiates the write sequence. The first transition HIGH of  $\overline{CE}$ ,  $\overline{BEn}$ , and  $\overline{R/\overline{W}}$  terminates the write sequence.
- If the  $\overline{CE}$  or  $\overline{SEM} = V_{IL}$  transition occurs simultaneously with or after the  $\overline{R/\overline{W}} = V_{IL}$  transition, the outputs remain in the High-impedance state.
- The timing represented in this cycle can be repeated multiple times to execute sequential RapidWrite Mode writes.
- This parameter is guaranteed by device characterization, but is not production tested. Transition is measured 0mV from steady state with the Output Test Load (Figure 1).
- To access RAM,  $\overline{CE} = V_{IL}$  and  $\overline{SEM} = V_{IH}$ . To access semaphore,  $\overline{CE} = V_{IH}$  and  $\overline{SEM} = V_{IL}$ .  $t_{EW}$  must be met for either condition.  $\overline{CE} = V_{IL}$  when  $\overline{CE0} = V_{IL}$  and  $CE1 = V_{IH}$ .  $\overline{CE} = V_{IH}$  when  $\overline{CE0} = V_{IH}$  and/or  $CE1 = V_{IL}$ .

### AC Electrical Characteristics over the Operating Temperature Range and Supply Voltage Range for RapidWrite Mode Write Cycle<sup>(1)</sup>

Symbol	Parameter	Min	Max	Unit
t <sub>AAS</sub>	Allowable Address Skew for RapidWrite Mode	—	1	ns
t <sub>ARF</sub>	Address Rise/Fall Time for RapidWrite Mode	1.5	—	V/ns

5679 tbl 14

**NOTE:**

1. Timing applies to all speed grades when utilizing the RapidWrite Mode Write Cycle.

### Timing Waveform of Address Inputs for RapidWrite Mode Write Cycle

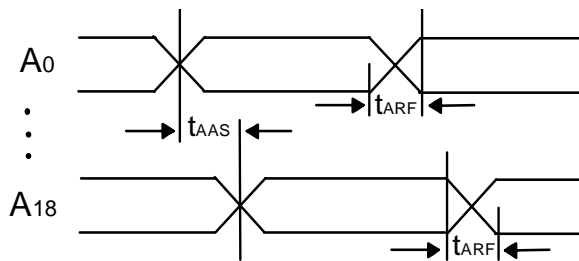

5679 drw 09

### Timing Waveform of Semaphore Read after Write Timing, Either Side<sup>(1)</sup>

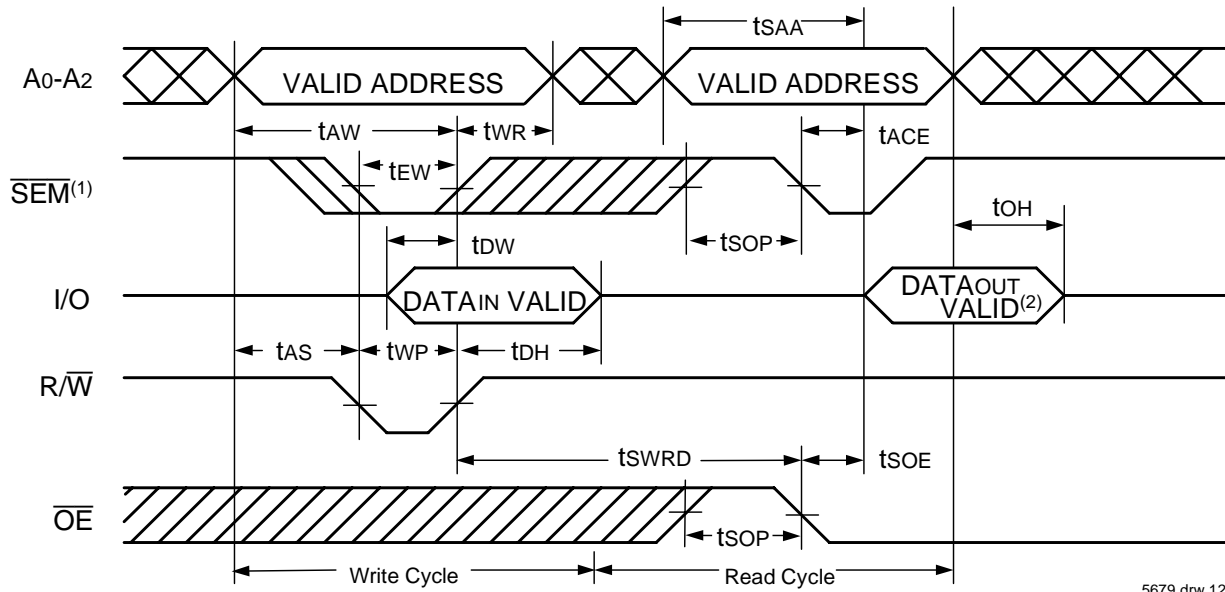

5679 drw 12

**NOTES:**

1.  $\overline{CE}_0 = V_{IH}$  and  $CE_1 = V_{IL}$  are required for the duration of both the write cycle and the read cycle waveforms shown above. Refer to Truth Table II for details and for appropriate  $\overline{BEn}$  controls.
2. "DATAOUT VALID" represents all I/O's (I/O<sub>0</sub> - I/O<sub>8</sub> and I/O<sub>18</sub> - I/O<sub>26</sub>) equal to the semaphore value.

### Timing Waveform of Semaphore Write Contention<sup>(1,3,4)</sup>

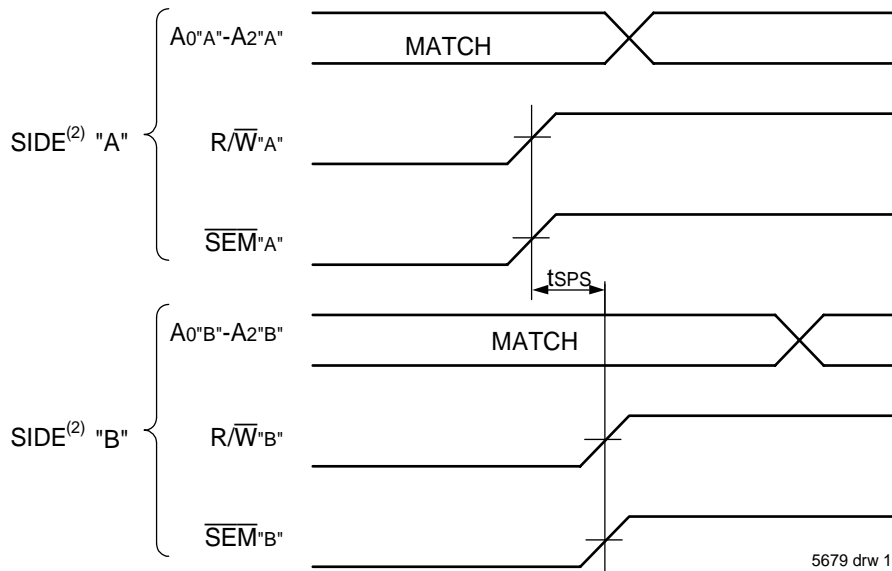

5679 drw 13

**NOTES:**

1.  $DOR = DOL = V_{IL}$ ,  $\overline{CE}_L = \overline{CE}_R = V_{IH}$ . Refer to Truth Table II for appropriate  $\overline{BE}$  controls.
2. All timing is the same for left and right ports. Port "A" may be either left or right port. "B" is the opposite from port "A".
3. This parameter is measured from R/W'A' or SEM'A' going HIGH to R/W'B' or SEM'B' going HIGH.
4. If t<sub>SPS</sub> is not satisfied, the semaphore will fall positively to one side or the other, but there is no guarantee which side will be granted the semaphore flag.

## AC Electrical Characteristics Over the Operating Temperature and Supply Voltage Range

Symbol	Parameter	70T653MS10 Com'l Only		70T653MS12 Com'l & Ind		70T653MS15 Com'l Only		Unit
		Min.	Max.	Min.	Max.	Min.	Max.	
<b>BUSY TIMING</b>								
t <sub>WB</sub>	$\overline{\text{BUSY}}$ Input to Write <sup>(4)</sup>	0	—	0	—	0	—	ns
t <sub>WH</sub>	Write Hold After $\overline{\text{BUSY}}$ <sup>(5)</sup>	7	—	9	—	12	—	ns
<b>PORT-TO-PORT DELAY TIMING</b>								
t <sub>WDD</sub>	Write Pulse to Data Delay <sup>(1)</sup>	—	14	—	16	—	20	ns
t <sub>DDD</sub>	Write Data Valid to Read Data Delay <sup>(1)</sup>	—	14	—	16	—	20	ns

5679 tbl 15

### NOTES:

- Port-to-port delay through RAM cells from writing port to reading port, refer to Timing Waveform of Write with Port-to-Port Read.
- To ensure that the earlier of the two ports wins.
- t<sub>WDD</sub> is a calculated parameter and is the greater of the Max. spec, t<sub>WDD</sub> – t<sub>WP</sub> (actual), or t<sub>DDD</sub> – t<sub>DR</sub> (actual).
- To ensure that the write cycle is inhibited on port "B" during contention on port "A".
- To ensure that a write cycle is completed on port "B" after contention on port "A".

## AC Electrical Characteristics Over the Operating Temperature and Supply Voltage Range<sup>(1,2,3)</sup>

Symbol	Parameter	70T65M3S10 Com'l Only		70T653MS12 Com'l & Ind		70T6539MS15 Com'l Only		
		Min.	Max.	Min.	Max.	Min.	Max.	
<b>SLEEP MODE TIMING (ZZx=V<sub>IH</sub>)</b>								
t <sub>zS</sub>	Sleep Mode Set Time	10	—	12	—	15	—	
t <sub>zR</sub>	Sleep Mode Reset Time	10	—	12	—	15	—	
t <sub>zPD</sub>	Sleep Mode Power Down Time <sup>(4)</sup>	10	—	12	—	15	—	
t <sub>zPU</sub>	Sleep Mode Power Up Time <sup>(4)</sup>	—	0	—	0	—	0	

5679 tbl 15a

### NOTES:

- Timing is the same for both ports.
- The sleep mode pin shuts off all dynamic inputs, except JTAG inputs, when asserted. OPT<sub>x</sub>,  $\overline{\text{INT}}_x$  and the sleep mode pins themselves (ZZx) are not affected during sleep mode. It is recommended that boundary scan not be operated during sleep mode.
- These values are valid regardless of the power supply level selected for I/O and control signals (3.3V/2.5V). See page 6 for details.
- This parameter is guaranteed by device characterization, but is not production tested.

### Timing Waveform of Write with Port-to-Port Read<sup>(1,3)</sup>

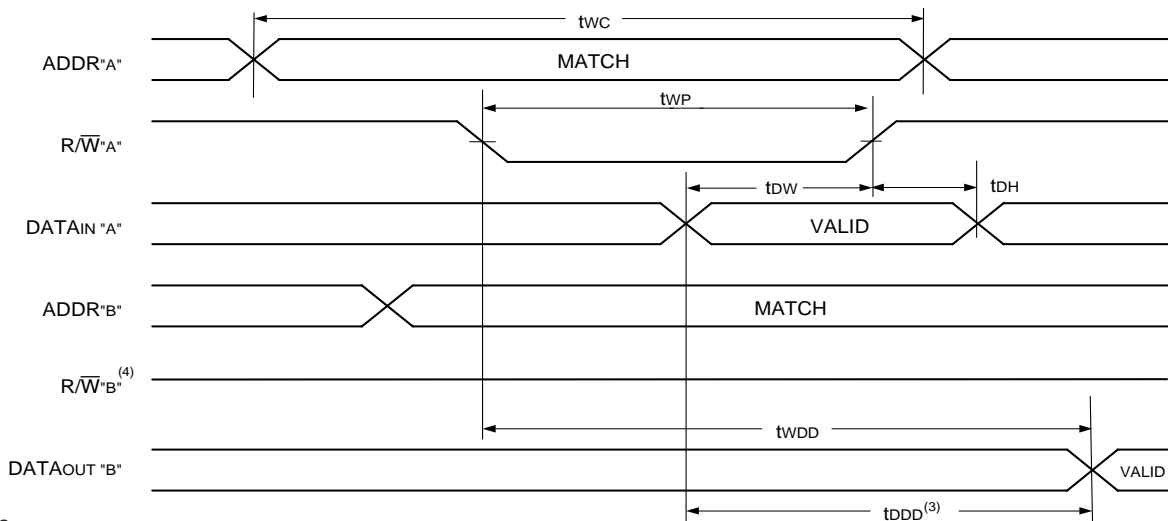

**NOTES:**

1.  $\overline{CE}_{0L} = \overline{CE}_{0R} = V_{IL}$ ;  $CE_{1L} = CE_{1R} = V_{IH}$ .
2.  $\overline{OE} = V_{IL}$  for the reading port.
3. All timing is the same for left and right ports. Port "A" may be either the left or right port. Port "B" is the port opposite from port "A".
4.  $R/\overline{W}_B = V_{IH}$ .

5679 drw 14a

### Timing Waveform of Write with **BUSY**

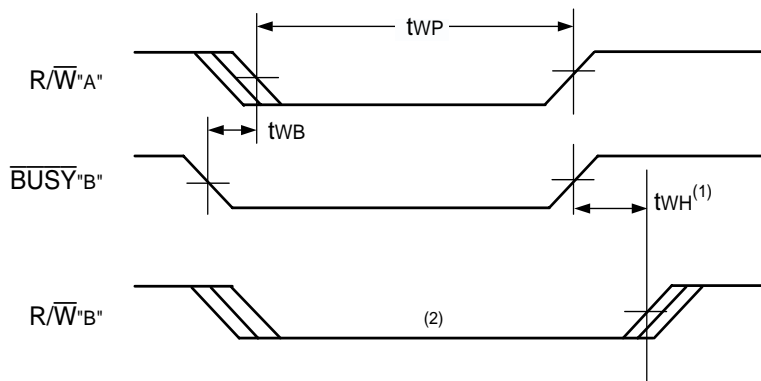

**NOTES:**

1.  $t_{wH}$  must be met for  $\overline{BUSY}$  input.
2.  $\overline{BUSY}$  is asserted on port "B" blocking  $R/\overline{W}$ "B", until  $\overline{BUSY}$ "B" goes HIGH.

5679 drw 15

### AC Electrical Characteristics Over the Operating Temperature and Supply Voltage Range<sup>(1,2)</sup>

Symbol	Parameter	70T653MS10 Com'l Only		70T653MS12 Com'l & Ind		70T653MS15 Com'l Only		Unit	
		Min.	Max.	Min.	Max.	Min.	Max.		
<b>INTERRUPT TIMING</b>									
$t_{AS}$	Address Set-up Time	0	—	0	—	0	—	ns	
$t_{WR}$	Write Recovery Time	0	—	0	—	0	—	ns	
$t_{INS}$	Interrupt Set Time	—	10	—	12	—	15	ns	
$t_{NR}$	Interrupt Reset Time	—	10	—	12	—	15	ns	

**NOTES:**

1. Timing is the same for both ports.
2. These values are valid regardless of the power supply level selected for I/O and control signals (3.3V/2.5V). See page 6 for details.

5679 tbl 16

### Waveform of Interrupt Timing<sup>(1)</sup>

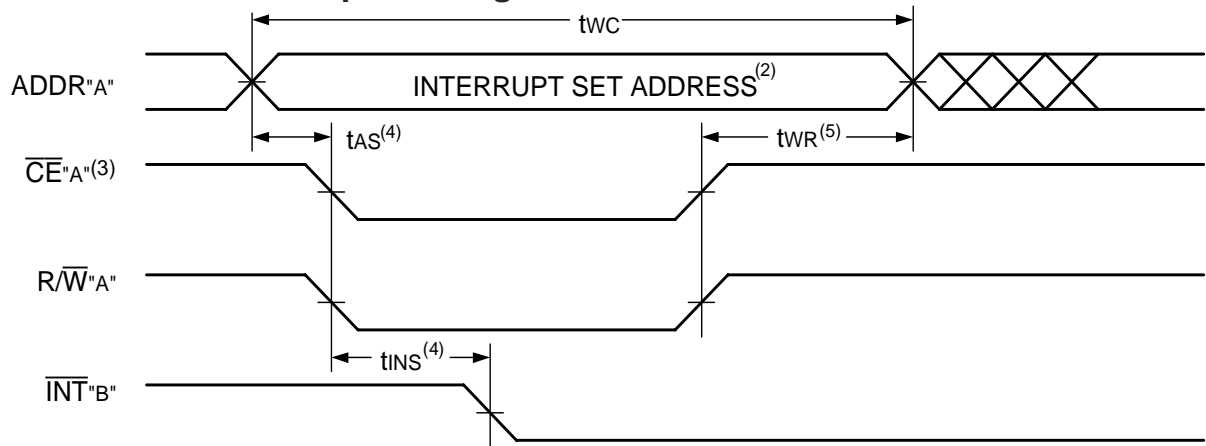

5679 drw 18

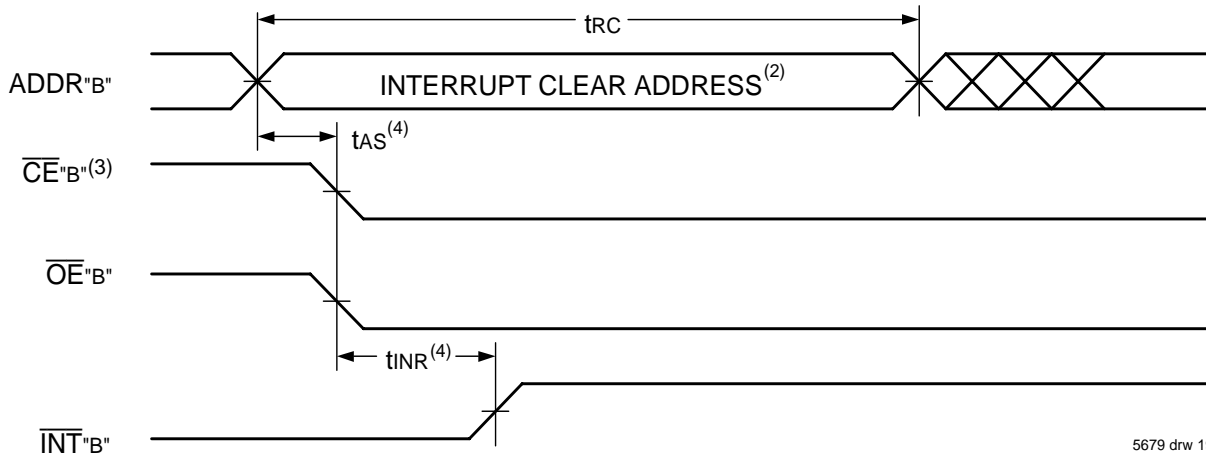

5679 drw 19

**NOTES:**

1. All timing is the same for left and right ports. Port "A" may be either the left or right port. Port "B" is the port opposite from port "A".
2. Refer to Interrupt Truth Table.
3.  $\overline{CE}_x = V_{IL}$  means  $\overline{CE}_{0x} = V_{IL}$  and  $CE_{1x} = V_{IH}$ .  $\overline{CE}_x = V_{IH}$  means  $\overline{CE}_{0x} = V_{IH}$  and/or  $CE_{1x} = V_{IL}$ .
4. Timing depends on which enable signal ( $\overline{CE}$  or  $R/\overline{W}$ ) is asserted last.
5. Timing depends on which enable signal ( $\overline{CE}$  or  $R/\overline{W}$ ) is de-asserted first.

### Truth Table III — Interrupt Flag<sup>(1,4)</sup>

Left Port					Right Port					Function
R/ $\overline{W}$ L	$\overline{CE}$ L	$\overline{OE}$ L	A18L-A0L	$\overline{INT}$ L	R/ $\overline{W}$ R	$\overline{CE}$ R	$\overline{OE}$ R	A18R-A0R	$\overline{INT}$ R	
L	L	X	7FFFF	X	X	X	X	X	L <sup>(2)</sup>	Set Right $\overline{INT}$ R Flag
X	X	X	X	X	X	L	L	7FFFF	H <sup>(3)</sup>	Reset Right $\overline{INT}$ R Flag
X	X	X	X	L <sup>(3)</sup>	L	L	X	7FFFE	X	Set Left $\overline{INT}$ L Flag
X	L	L	7FFFE	H <sup>(2)</sup>	X	X	X	X	X	Reset Left $\overline{INT}$ L Flag

5679 tbl 17

**NOTES:**

1. Assumes  $\overline{BUSY}_L = \overline{BUSY}_R = V_{IH}$ .  $\overline{CE}_{0x} = V_{IL}$  and  $CE_{1x} = V_{IH}$ .
2. If  $\overline{BUSY}_L = V_{IL}$ , then no change.
3. If  $\overline{BUSY}_R = V_{IL}$ , then no change.
4.  $\overline{INT}$ L and  $\overline{INT}$ R must be initialized at power-up.

**Truth Table IV — Example of Semaphore Procurement Sequence<sup>(1,2,3)</sup>**

Functions	D <sub>0</sub> - D <sub>8</sub> Left D <sub>18</sub> - D <sub>26</sub> Left	D <sub>0</sub> - D <sub>8</sub> Right D <sub>18</sub> - D <sub>26</sub> Right	Status
No Action	1	1	Semaphore free
Left Port Writes "0" to Semaphore	0	1	Left port has semaphore token
Right Port Writes "0" to Semaphore	0	1	No change. Right side has no write access to semaphore
Left Port Writes "1" to Semaphore	1	0	Right port obtains semaphore token
Left Port Writes "0" to Semaphore	1	0	No change. Left port has no write access to semaphore
Right Port Writes "1" to Semaphore	0	1	Left port obtains semaphore token
Left Port Writes "1" to Semaphore	1	1	Semaphore free
Right Port Writes "0" to Semaphore	1	0	Right port has semaphore token
Right Port Writes "1" to Semaphore	1	1	Semaphore free
Left Port Writes "0" to Semaphore	0	1	Left port has semaphore token
Left Port Writes "1" to Semaphore	1	1	Semaphore free

5679 b1 19

**NOTES:**

1. This table denotes a sequence of events for only one of the eight semaphores on the IDT70T653M.
2. There are eight semaphore flags written to via I/O<sub>0</sub> and read from I/Os (I/O<sub>0</sub>-I/O<sub>8</sub> and I/O<sub>18</sub>-I/O<sub>26</sub>). These eight semaphores are addressed by A<sub>0</sub> - A<sub>2</sub>.
3.  $\overline{CE} = V_{IH}$ ,  $\overline{SEM} = V_{IL}$  to access the semaphores. Refer to the Semaphore Read/Write Control Truth Table.

**Functional Description**

The IDT70T653M provides two ports with separate control, address and I/O pins that permit independent access for reads or writes to any location in memory. The IDT70T653M has an automatic power down feature controlled by  $\overline{CE}$ . The  $\overline{CE}_0$  and  $CE_1$  control the on-chip power down circuitry that permits the respective port to go into a standby mode when not selected ( $\overline{CE} = \text{HIGH}$ ). When a port is enabled, access to the entire memory array is permitted.

**Interrupts**

If the user chooses the interrupt function, a memory location (mail box or message center) is assigned to each port. The left port interrupt flag ( $\overline{INT}_L$ ) is asserted when the right port writes to memory location 7FFFE (HEX), where a write is defined as  $\overline{CE}_R = R/\overline{WR} = V_{IL}$  per the Truth Table. The left port clears the interrupt through access of address location 7FFFE when  $\overline{CE}_L = \overline{OE}_L = V_{IL}$ ,  $R/\overline{W}$  is a "don't care". Likewise, the right port interrupt flag ( $\overline{INT}_R$ ) is asserted when the left port writes to memory location 7FFFF (HEX) and to clear the interrupt flag ( $\overline{INT}_R$ ), the right port must read the memory location 7FFFF. The message (36 bits) at 7FFFE or 7FFFF is user-defined since it is an addressable SRAM location. If the interrupt function is not used, address locations 7FFFE and 7FFFF are not used as mail boxes, but as part of the random access memory. Refer to Truth Table III for the interrupt operation.

**Busy Logic**

The  $\overline{BUSY}$  pin operates as a write inhibit input pin. Normal operation can be programmed by tying the  $\overline{BUSY}$  pins HIGH. If desired, unintended write operations can be prevented to a port by tying the  $\overline{BUSY}$  pin for that port LOW.

**Semaphores**

The IDT70T653M is an extremely fast Dual-Port 512K x 36 CMOS Static RAM with an additional 8 address locations dedicated to binary

semaphore flags. These flags allow either processor on the left or right side of the Dual-Port RAM to claim a privilege over the other processor for functions defined by the system designer's software. As an example, the semaphore can be used by one processor to inhibit the other from accessing a portion of the Dual-Port RAM or any other shared resource.

The Dual-Port RAM features a fast access time, with both ports being completely independent of each other. This means that the activity on the left port in no way slows the access time of the right port. Both ports are identical in function to standard CMOS Static RAM and can be read from or written to at the same time with the only possible conflict arising from the simultaneous writing of, or a simultaneous READ/WRITE of, a non-semaphore location. Semaphores are protected against such ambiguous situations and may be used by the system program to avoid any conflicts in the non-semaphore portion of the Dual-Port RAM. These devices have an automatic power-down feature controlled by  $\overline{CE}_0$  and  $CE_1$ , the Dual-Port RAM chip enables, and  $\overline{SEM}$ , the semaphore enable. The  $\overline{CE}_0$ ,  $CE_1$ , and  $\overline{SEM}$  pins control on-chip power down circuitry that permits the respective port to go into standby mode when not selected.

Systems which can best use the IDT70T653M contain multiple processors or controllers and are typically very high-speed systems which are software controlled or software intensive. These systems can benefit from a performance increase offered by the IDT70T653Ms hardware semaphores, which provide a lockout mechanism without requiring complex programming.

Software handshaking between processors offers the maximum in system flexibility by permitting shared resources to be allocated in varying configurations. The IDT70T653M does not use its semaphore flags to control any resources through hardware, thus allowing the system designer total flexibility in system architecture.

An advantage of using semaphores rather than the more common methods of hardware arbitration is that wait states are never incurred in either processor. This can prove to be a major advantage in very high-speed systems.

## How the Semaphore Flags Work

The semaphore logic is a set of eight latches which are independent of the Dual-Port RAM. These latches can be used to pass a flag, or token, from one port to the other to indicate that a shared resource is in use. The semaphores provide a hardware assist for a use assignment method called "Token Passing Allocation." In this method, the state of a semaphore latch is used as a token indicating that a shared resource is in use. If the left processor wants to use this resource, it requests the token by setting the latch. This processor then verifies its success in setting the latch by reading it. If it was successful, it proceeds to assume control over the shared resource. If it was not successful in setting the latch, it determines that the right side processor has set the latch first, has the token and is using the shared resource. The left processor can then either repeatedly request that semaphore's status or remove its request for that semaphore to perform another task and occasionally attempt again to gain control of the token via the set and test sequence. Once the right side has relinquished the token, the left side should succeed in gaining control.

The semaphore flags are active LOW. A token is requested by writing a zero into a semaphore latch and is released when the same side writes a one to that latch.

The eight semaphore flags reside within the IDT70T653M in a separate memory space from the Dual-Port RAM. This address space is accessed by placing a low input on the  $\overline{\text{SEM}}$  pin (which acts as a chip select for the semaphore flags) and using the other control pins (Address,  $\overline{\text{CE}}_0$ ,  $\text{CE}_1$ ,  $\overline{\text{R}}/\overline{\text{W}}$  and  $\overline{\text{B}}\overline{\text{E}}_n$ ) as they would be used in accessing a standard Static RAM. Each of the flags has a unique address which can be accessed by either side through address pins  $\text{A}_0$ – $\text{A}_2$ . When accessing the semaphores, none of the other address pins has any effect.

When writing to a semaphore, only data pin  $\text{D}_0$  is used. If a low level is written into an unused semaphore location, that flag will be set to a zero on that side and a one on the other side (see Truth Table IV). That semaphore can now only be modified by the side showing the zero. When a one is written into the same location from the same side, the flag will be set to a one for both sides (unless a semaphore request from the other side is pending) and then can be written to by both sides. The fact that the side which is able to write a zero into a semaphore subsequently locks out writes from the other side is what makes semaphore flags useful in interprocessor communications. (A thorough discussion on the use of this feature follows shortly.) A zero written into the same location from the other side will be stored in the semaphore request latch for that side until the semaphore is freed by the first side.

When a semaphore flag is read, its value is spread into all data bits so that a flag that is a one reads as a one in all data bits and a flag containing a zero reads as all zeros for a semaphore read, the  $\overline{\text{SEM}}$ ,  $\overline{\text{B}}\overline{\text{E}}_n$ , and  $\overline{\text{OE}}$  signals need to be active. (Please refer to Truth Table II). Furthermore, the read value is latched into one side's output register when that side's semaphore select ( $\overline{\text{SEM}}$ ,  $\overline{\text{B}}\overline{\text{E}}_n$ ) and output enable ( $\overline{\text{OE}}$ ) signals go active. This serves to disallow the semaphore from changing state in the middle of a read cycle due to a write cycle from the other side.

A sequence WRITE/READ must be used by the semaphore in order to guarantee that no system level contention will occur. A processor requests access to shared resources by attempting to write a zero into a semaphore location. If the semaphore is already in use, the semaphore request latch will contain a zero, yet the semaphore flag will appear as one, a fact which the processor will verify by the

subsequent read (see Table IV). As an example, assume a processor writes a zero to the left port at a free semaphore location. On a subsequent read, the processor will verify that it has written successfully to that location and will assume control over the resource in question. Meanwhile, if a processor on the right side attempts to write a zero to the same semaphore flag it will fail, as will be verified by the fact that a one will be read from that semaphore on the right side during subsequent read. Had a sequence of READ/WRITE been used instead, system contention problems could have occurred during the gap between the read and write cycles.

It is important to note that a failed semaphore request must be followed by either repeated reads or by writing a one into the same location. The reason for this is easily understood by looking at the simple logic diagram

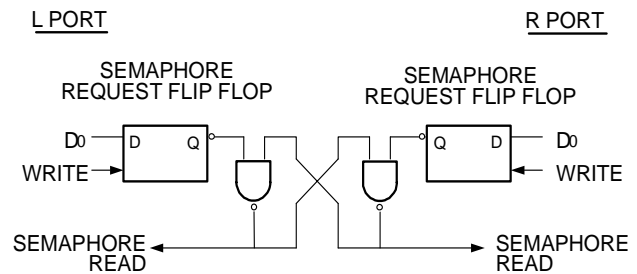

5679 drw 21

Figure 4. IDT70T653M Semaphore Logic

of the semaphore flag in Figure 4. Two semaphore request latches feed into a semaphore flag. Whichever latch is first to present a zero to the semaphore flag will force its side of the semaphore flag LOW and the other side HIGH. This condition will continue until a one is written to the same semaphore request latch. If the opposite side semaphore request latch has been written to zero in the meantime, the semaphore flag will flip over to the other side as soon as a one is written into the first request latch. The opposite side flag will now stay LOW until its semaphore request latch is written to a one. From this it is easy to understand that, if a semaphore is requested and the processor which requested it no longer needs the resource, the entire system can hang up until a one is written into that semaphore request latch.

The critical case of semaphore timing is when both sides request a single token by attempting to write a zero into it at the same time. The semaphore logic is specially designed to resolve this problem. If simultaneous requests are made, the logic guarantees that only one side receives the token. If one side is earlier than the other in making the request, the first side to make the request will receive the token. If both requests arrive at the same time, the assignment will be arbitrarily made to one port or the other.

One caution that should be noted when using semaphores is that semaphores alone do not guarantee that access to a resource is secure. As with any powerful programming technique, if semaphores are misused or misinterpreted, a software error can easily happen.

Initialization of the semaphores is not automatic and must be handled via the initialization program at power-up. Since any semaphore request flag which contains a zero must be reset to a one, all semaphores on both sides should have a one written into them at initialization from both sides to assure that they will be free when needed.

## Timing Waveform of Sleep Mode<sup>(1,2)</sup>

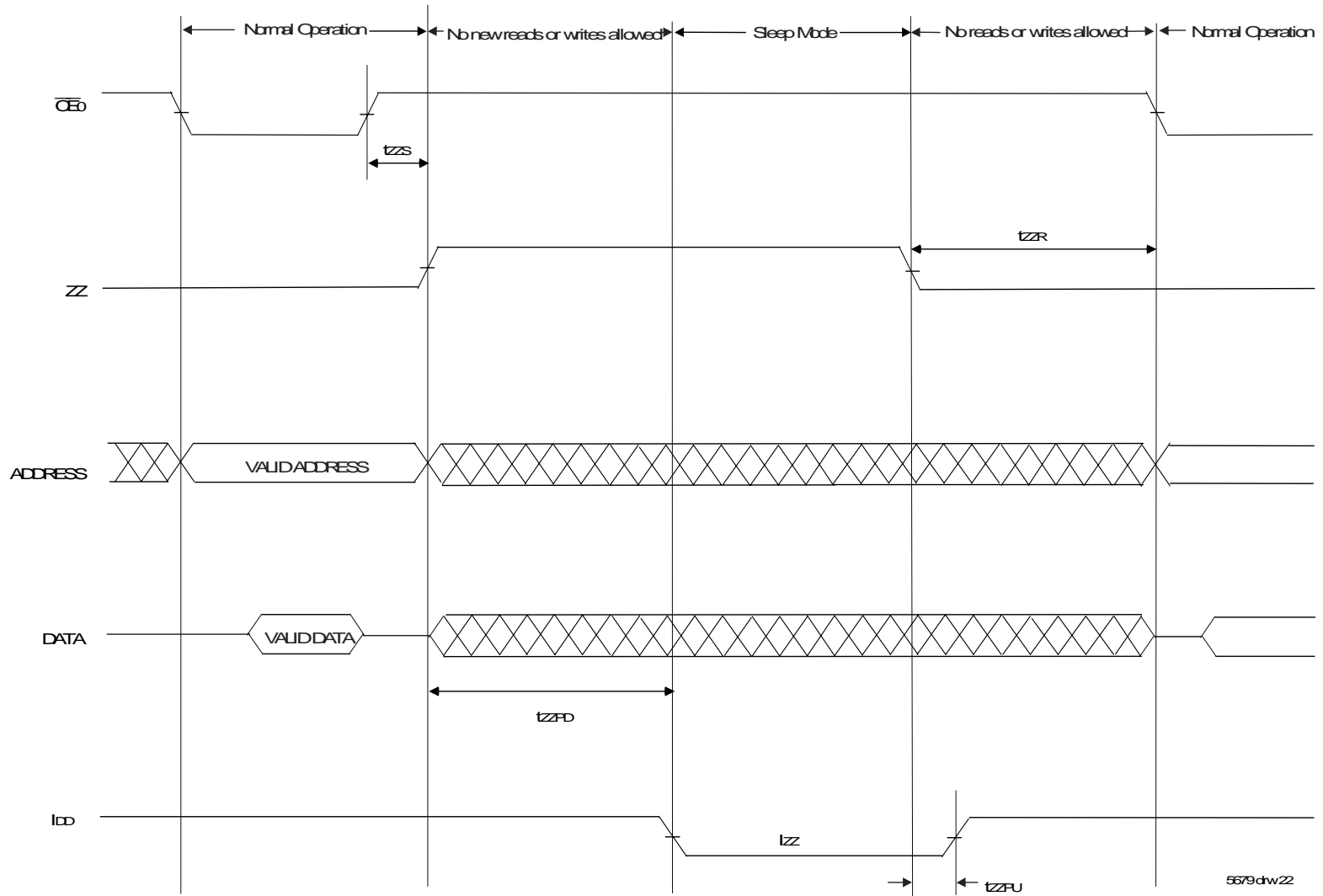

5679 dw22

### NOTES:

1.  $CE1 = V_{IH}$ .
2. All timing is same for Left and Right ports.

## Sleep Mode

The IDT70T653M is equipped with an optional sleep or low power mode on both ports. The sleep mode pin on both ports is active high. During normal operation, the ZZ pin is pulled low. When ZZ is pulled high, the port will enter sleep mode where it will meet lowest possible power conditions. The sleep mode timing diagram shows the modes of operation: Normal Operation, No Read/Write Allowed and Sleep Mode.

For a period of time prior to sleep mode and after recovering from sleep mode (tzrs and tzrr), new reads or writes are not allowed. If a write or read

operation occurs during these periods, the memory array may be corrupted. Validity of data out from the RAM cannot be guaranteed immediately after ZZ is asserted (prior to being in sleep).

During sleep mode the RAM automatically deselects itself. The RAM disconnects its internal buffer. All outputs will remain in high-Z state while in sleep mode. All inputs are allowed to toggle. The RAM will not be selected and will not perform any reads or writes.

## JTAG Functionality and Configuration

The IDT70T653M is composed of two independent memory arrays, and thus cannot be treated as a single JTAG device in the scan chain. The two arrays (A and B) each have identical characteristics and commands but must be treated as separate entities in JTAG operations. Please refer to Figure 5.

JTAG signaling must be provided serially to each array and utilizes the information provided in the Identification Register Definitions, Scan

Register Sizes, and System Interface Parameter tables. Specifically, commands for Array B must precede those for Array A in any JTAG operations sent to the IDT70T653M. Please reference Application Note AN-411, "JTAG Testing of Multichip Modules" for specific instructions on performing JTAG testing on the IDT70T653M. AN-411 is available at [www.idt.com](http://www.idt.com).

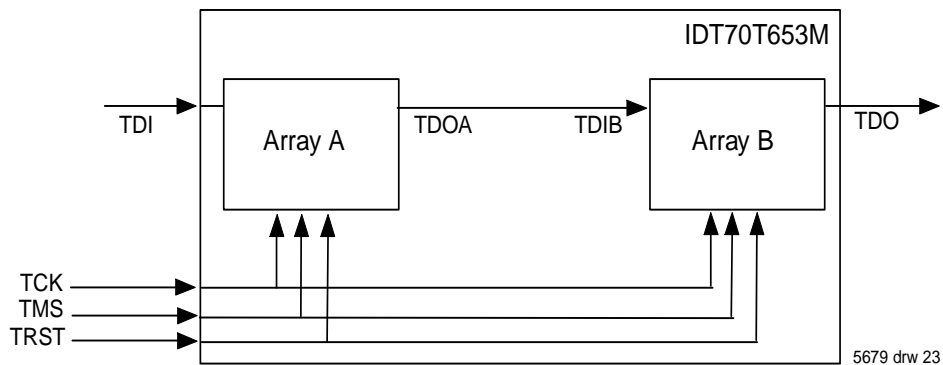
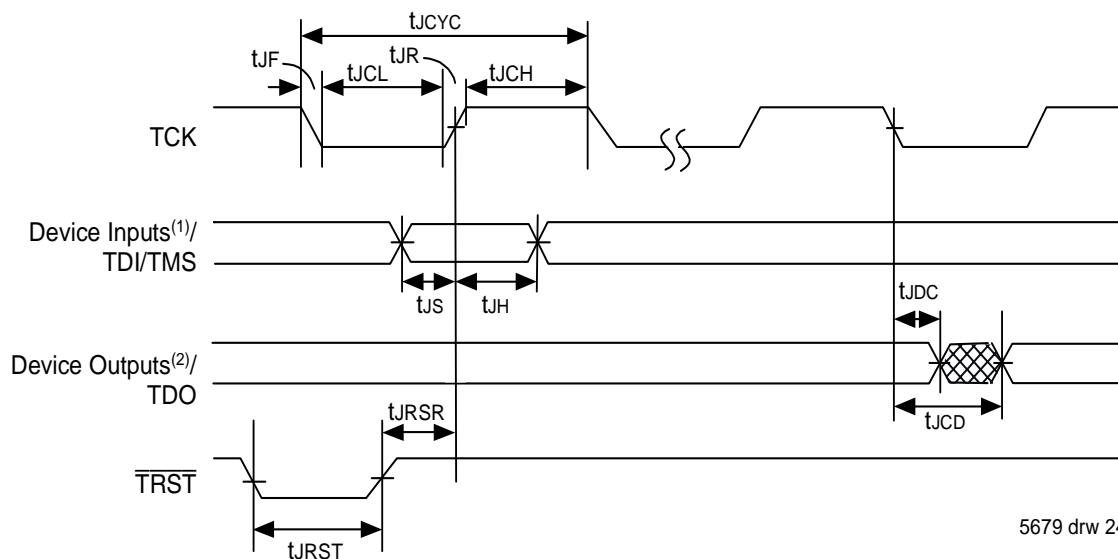

Figure 5. JTAG Configuration for IDT70T653M

## JTAG Timing Specifications



5679 drw 24

### NOTES:

1. Device inputs = All device inputs except TDI, TMS, TCK and  $\overline{TRST}$ .
2. Device outputs = All device outputs except TDO.

## JTAG AC Electrical Characteristics<sup>(1,2,3,4,5)</sup>

Symbol	Parameter	70T653M		
		Min.	Max.	Units
$t_{JCYC}$	JTAG Clock Input Period	100	—	ns
$t_{JCH}$	JTAG Clock HIGH	40	—	ns
$t_{JCL}$	JTAG Clock Low	40	—	ns
$t_{JR}$	JTAG Clock Rise Time	—	3 <sup>(1)</sup>	ns
$t_{JF}$	JTAG Clock Fall Time	—	3 <sup>(1)</sup>	ns
$t_{JRST}$	JTAG Reset	50	—	ns
$t_{JRSR}$	JTAG Reset Recovery	50	—	ns
$t_{JCD}$	JTAG Data Output	—	25	ns
$t_{JDC}$	JTAG Data Output Hold	0	—	ns
$t_{JS}$	JTAG Setup	15	—	ns
$t_{JH}$	JTAG Hold	15	—	ns

5679 tbl 20

### NOTES:

1. Guaranteed by design.
2. 30pF loading on external output signals.
3. Refer to AC Electrical Test Conditions stated earlier in this document.
4. JTAG operations occur at one speed (10MHz). The base device may run at any speed specified in this datasheet.
5. JTAG cannot be tested in sleep mode.

## Identification Register Definitions

Instruction Field Array B	Value Array B	Instruction Field Array A	Value Array A	Description
Revision Number (31:28)	0x0	Revision Number (63:60)	0x0	Reserved for Version number
IDT Device ID (27:12)	0x33B	IDT Device ID (59:44)	0x33B	Defines IDT Part number
IDT JEDEC ID (11:1)	0x33	IDT JEDEC ID (43:33)	0x33	Allows unique identification of device vendor as IDT
ID Register Indicator Bit (Bit 0)	1	ID Register Indicator Bit (Bit 32)	1	Indicates the presence of an ID Register

5679 tbl 21

## Scan Register Sizes

Register Name	Bit Size Array A	Bit Size Array B	Bit Size 70T653M
Instruction (IR)	4	4	8
Bypass (BYR)	1	1	2
Identification (IDR)	32	32	64
Boundary Scan (BSR)	Note (3)	Note (3)	Note (3)

5679 tbl 22

## System Interface Parameters

Instruction	Code	Description
EXTEST	00000000	Forces contents of the boundary scan cells onto the device outputs <sup>(1)</sup> . Places the boundary scan register (BSR) between TDI and TDO.
BYPASS	11111111	Places the bypass register (BYR) between TDI and TDO.
IDCODE	00100010	Loads the ID register (IDR) with the vendor ID code and places the register between TDI and TDO.
HIGHZ	01000100	Places the bypass register (BYR) between TDI and TDO. Forces all device output drivers to a High-Z state.
CLAMP	00110011	Uses BYR. Forces contents of the boundary scan cells onto the device outputs. Places the bypass register (BYR) between TDI and TDO.
SAMPLE/PRELOAD	00010001	Places the boundary scan register (BSR) between TDI and TDO. SAMPLE allows data from device inputs <sup>(2)</sup> and outputs <sup>(1)</sup> to be captured in the boundary scan cells and shifted serially through TDO. PRELOAD allows data to be input serially into the boundary scan cells via the TDI.
RESERVED	All Other Codes	Several combinations are reserved. Do not use codes other than those identified above.

5679 tbl 23

### NOTES:

1. Device outputs = All device outputs except TDO.
2. Device inputs = All device inputs except TDI, TMS, TCK and  $\overline{\text{TRST}}$ .
3. The Boundary Scan Descriptive Language (BSDL) file for this device is available on the IDT website ([www.idt.com](http://www.idt.com)), or by contacting your local IDT sales representative.

## Ordering Information

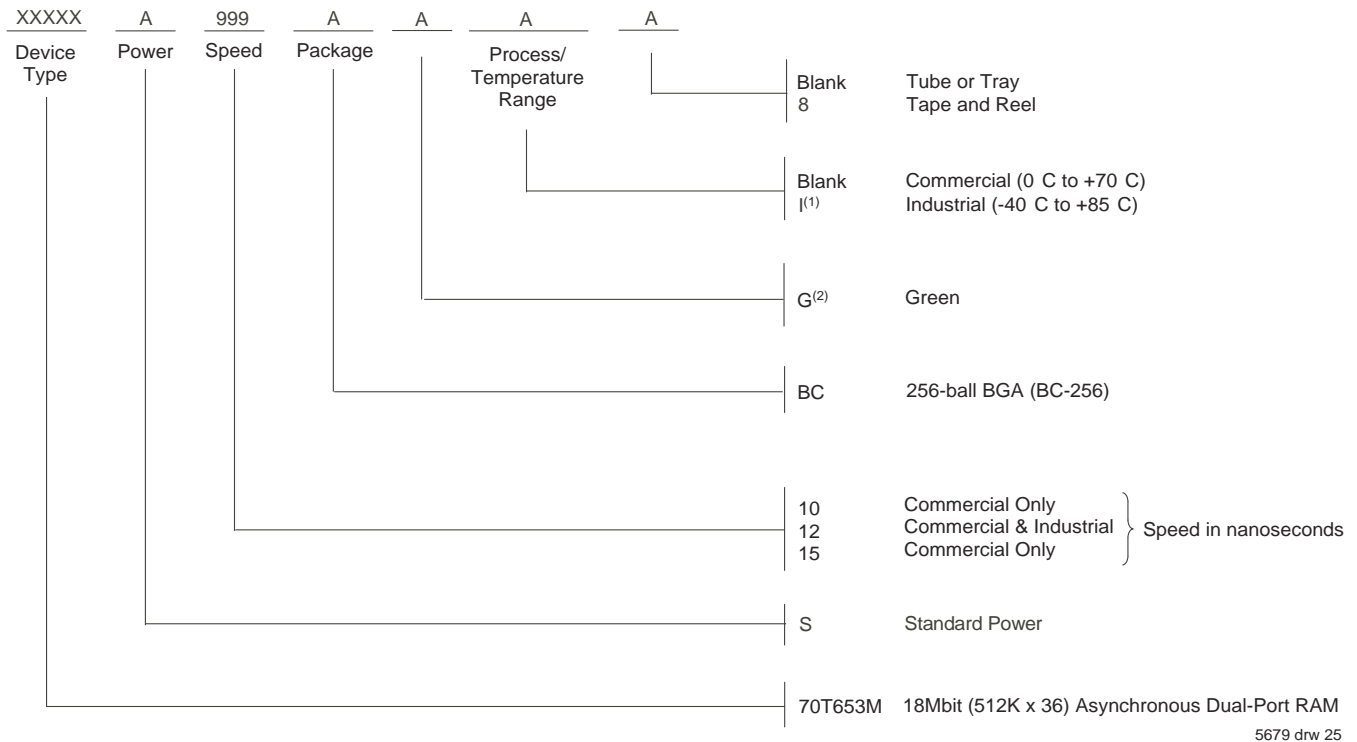

### NOTE:

1. Contact your local sales office for industrial temp range for other speeds, packages and powers.
2. Green parts available. For specific speeds, packages and powers contact your local sales office  
**LEAD FINISH (SnPb) parts are in EOL process. Product Discontinuation Notice - PDN# SP-17-02**

## Datasheet Document History:

- 10/08/03: Initial Datasheet
- 10/20/03: Page 1 Added "Includes JTAG functionality" to features  
Page 13 Corrected t<sub>ARF</sub> to 1.5V/ns Min
- 09/28/04: Removed "Preliminary" status  
Page 11 Updated Timing Waveform of Write Cycle No. 1, R<sub>W</sub> Controlled Timing  
Page 21 Added JTAG Configuration and JTAG Functionality descriptions  
Page 1 & 24 Replaced old ® logo with the new ™ logo
- 06/30/05: Page 1 Added green availability to features  
Page 24 Added green indicator to ordering information
- 07/25/08: Page 7 Corrected a typo in the DC Chars table
- 01/19/09: Page 24 Removed "IDT" from orderable part number
- 06/15/15: Page 3 Removed the date from the BC256 pin configuration  
Page 24 Added Tape and Reel indicators and added footnote annotations to the Ordering Information
- 12/08/17: Product Discontinuation Notice - PDN# SP-17-02  
Last time buy expires June 15, 2018



**CORPORATE HEADQUARTERS**  
 6024 Silver Creek Valley Road  
 San Jose, CA 95138

**for SALES:**  
 800-345-7015 or 408-284-8200  
 fax: 408-284-2775  
 www.idt.com

**for Tech Support:**  
 408-284-2794  
 DualPortHelp@idt.com

The IDT logo is a registered trademark of Integrated Device Technology, Inc.