

# 2 Phase Hybrid Stepper Motor 34H2B series-Size 86mm(1.8 degree)

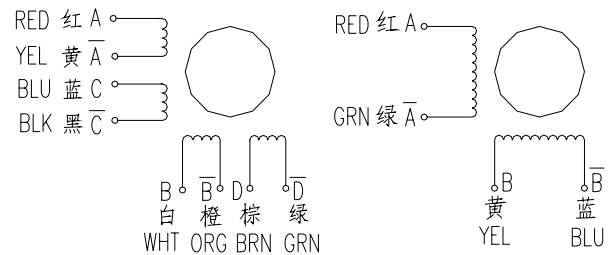

### Wiring Diagram:



UNI/BI-POLAR(8 LEADS)

BI-POLAR(4LEADS)

### Electrical Specifications (UNI-POLAR):

Series Model	Old P/N	Motor Length (mm)	Rated Current (A)	Phase Resistance (ohm)	Phase Inductance (mH)	Holding Torque (N.cm Min)	Detent Torque (N.cm Max)	Rotor Inertia (g.cm <sup>2</sup> )	Lead Wire (No.)	Motor Weight (kg)
34H2B6840	34HY6801	63	4.0	0.68	2.0	180	4.5	640	8	1.6
34H2B6850	34HY6802	63	5.0	0.45	1.5	180	4.5	640	8	1.6
34H2B6827	34HY6803	63	2.7	1.2	4.5	180	4.5	640	8	1.6
34H2B6821	34HY6804	63	2.1	1.9	7.2	180	4.5	640	8	1.6
34H2B9840	34HY9801	92	4.0	0.89	3.8	320	6.5	1300	8	2.6
34H2B9850	34HY9802	92	5.0	0.58	2.8	320	6.5	1300	8	2.6
34H2B9827	34HY9803	92	2.7	1.7	9.0	320	6.5	1300	8	2.6
34H2B9821	34HY9804	92	2.1	2.7	15	320	6.5	1300	8	2.6
34H2B1840	34HY1801	122	4.0	1.1	5.6	450	10.5	1900	8	3.8
34H2B1850	34HY1802	122	5.0	0.82	3.6	450	10.5	1900	8	3.8
34H2B1827	34HY1803	122	2.7	2.5	12.5	450	10.5	1900	8	3.8

#### \*Note:

- 1) We can manufacture products according to customer's requirements.
- 2) The Holding Torque of Bipolar = 1.414 x above Unipolar' Holding Torque.

### Dimensions: unit=mm

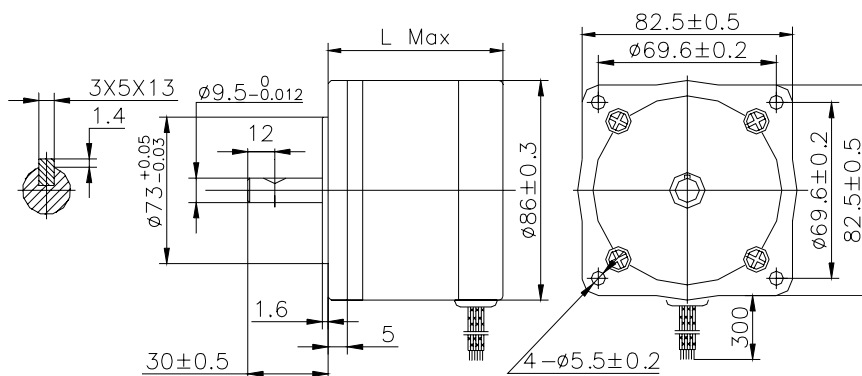

### Moto Length:

Model	Length
34H2B6XXX	63 mm
34H2B9XXX	92 mm
34H2B1XXX	122 mm