

# DATA SHEET

## **74F832, 74F1832** Hex 2-input OR drivers

Product specification

1991 Jan 02

IC15 Data Handbook

# Hex 2-input OR drivers

# 74F832/74F1832

## FEATURES

- High capacitive drive capability
- Choice of configuration  
 Corner V<sub>CC</sub> and GND – 74F832  
 Center V<sub>CC</sub> and GND – 74F1832
- Typical propagation delay of 3.5ns
- Superior ground noise characteristics (implemented using output edge rate control)
- Increased source and sink current (64mA)

TYPE	TYPICAL PROP-AGATION DELAY	TYPICAL SUPPLY CURRENT (TOTAL)
74F832	3.5ns	26mA
74F1832	3.5ns	26mA

## ORDERING INFORMATION

DESCRIPTION	ORDER CODE	PKG DWG #
	COMMERCIAL RANGE V <sub>CC</sub> = 5V ±10%, T <sub>amb</sub> = 0°C to +70°C	
20-pin plastic Dual In-line Package	N74F832N, N74F1832N	SOT146-1
20-pin plastic Small Outline Large	N74F832D, N74F1832D	SOT163-1

## INPUT AND OUTPUT LOADING AND FAN OUT TABLE

PINS	DESCRIPTION	74F (U.L.) HIGH/LOW	LOAD VALUE HIGH/LOW
D <sub>na</sub> – D <sub>nb</sub>	Data inputs	1.0/0.033	20µA/20µA
Q <sub>0</sub> – Q <sub>5</sub>	Data outputs	3200/106.7	64mA/64mA

**NOTE:** One (1.0) FAST unit load is defined as: 20µA in the high state and 0.6mA in the low state.

## PIN CONFIGURATION

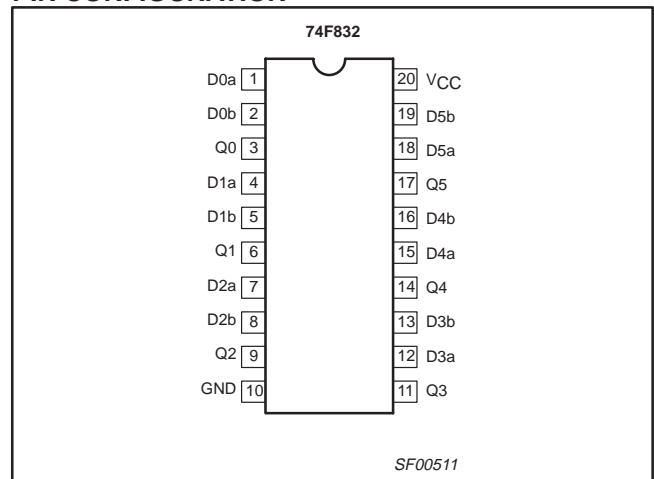

## LOGIC SYMBOL

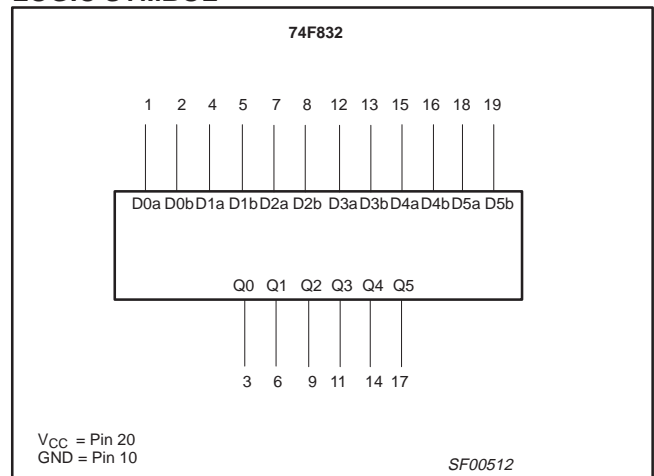

## IEC/IEEE SYMBOL

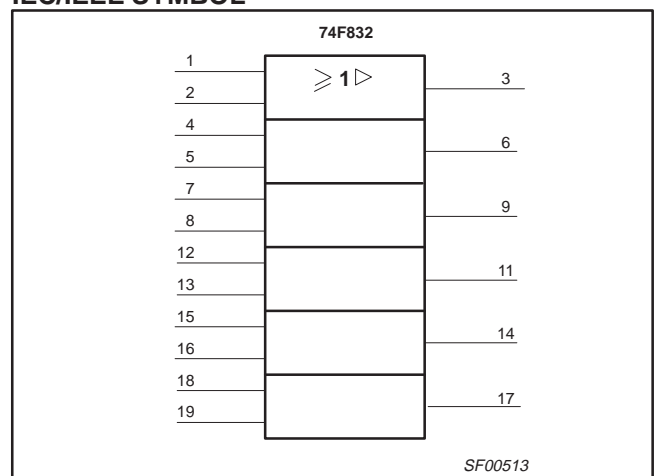

# Hex 2-input OR drivers

# 74F832/74F1832

## PIN CONFIGURATION

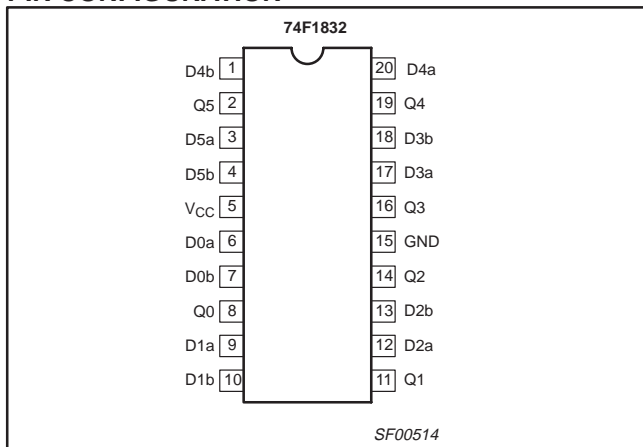

## LOGIC DIAGRAM

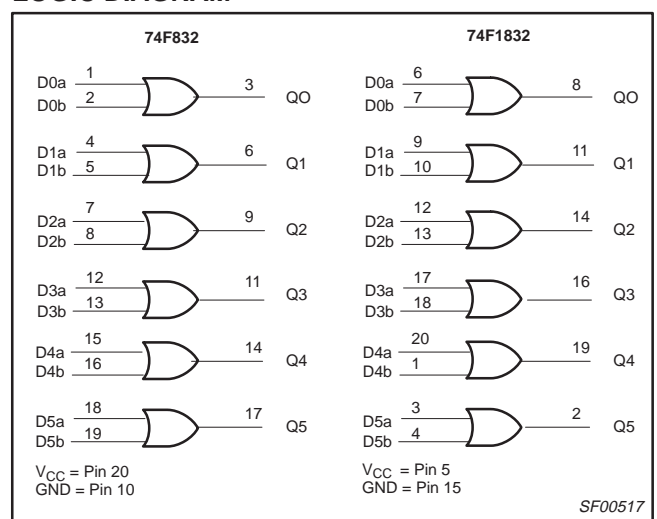

## LOGIC SYMBOL

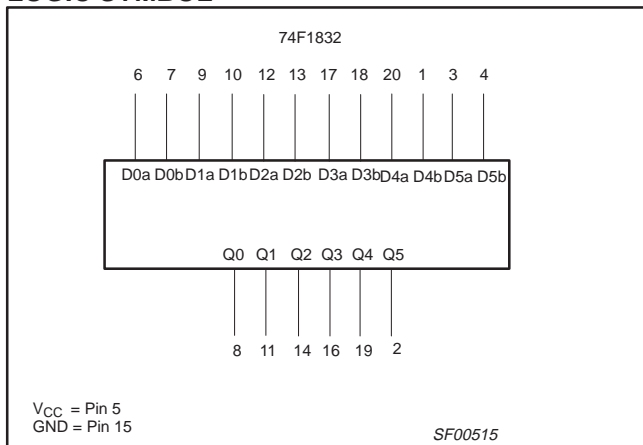

## FUNCTION TABLE

INPUTS		OUTPUT
Dna	Dnb	Qn
H	X	H
X	H	H
L	L	L

### NOTES:

- H = High voltage level
- L = Low voltage level
- X = Don't care

## IEC/IEEE SYMBOL

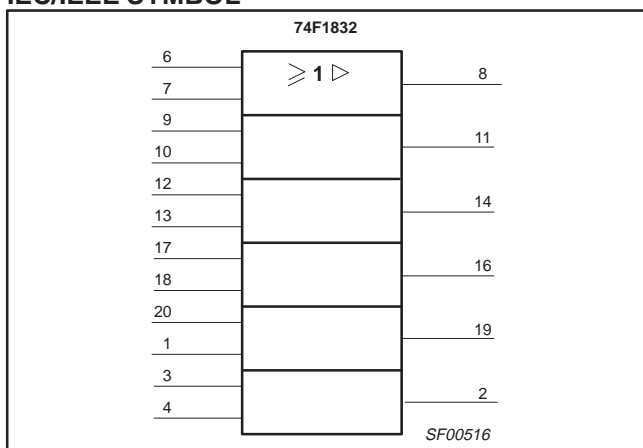

## Hex 2-input OR drivers

74F832/74F1832

**ABSOLUTE MAXIMUM RATINGS**

(Operation beyond the limit set forth in this table may impair the useful life of the device. Unless otherwise noted these limits are over the operating free air temperature range.)

SYMBOL	PARAMETER	RATING	UNIT
V <sub>CC</sub>	Supply voltage	-0.5 to +7.0	V
V <sub>IN</sub>	Input voltage	-0.5 to +7.0	V
I <sub>IN</sub>	Input current	-30 to +5	mA
V <sub>OUT</sub>	Voltage applied to output in high output state	-0.5 to V <sub>CC</sub>	V
I <sub>OUT</sub>	Current applied to output in low output state	96	mA
T <sub>amb</sub>	Operating free air temperature range	0 to +70	°C
T <sub>stg</sub>	Storage temperature range	-65 to +150	°C

**RECOMMENDED OPERATING CONDITIONS**

SYMBOL UNIT	PARAMETER	LIMITS			T <sub>A</sub> = -40 to +85°C
		MIN	NOM	MAX	
V <sub>CC</sub>	Supply voltage	4.5	5.0	5.5	V
V <sub>IH</sub>	High-level input voltage	2.0			V
V <sub>IL</sub>	Low-level input voltage			0.8	V
I <sub>IK</sub>	Input clamp current			-18	mA
I <sub>OH</sub>	High-level output current			-64	mA
I <sub>OL</sub>	Low-level output current			64	mA
T <sub>amb</sub>	Operating free air temperature range	0		+70	°C

**DC ELECTRICAL CHARACTERISTICS**

(Over recommended operating free-air temperature range unless otherwise noted.)

SYMBOL	PARAMETER	TEST CONDITIONS <sup>1</sup>	LIMITS			UNIT		
			MIN	TYP <sup>2</sup>	MAX			
V <sub>OH</sub>	High-level output voltage	V <sub>CC</sub> = MIN, V <sub>IL</sub> = MAX	±10%V <sub>CC</sub>	2.0		V		
		V <sub>IH</sub> = MIN, I <sub>OH</sub> = MAX	±5%V <sub>CC</sub>	2.0		V		
V <sub>OL</sub>	Low-level output voltage	V <sub>CC</sub> = MIN, V <sub>IL</sub> = MAX	±10%V <sub>CC</sub>		0.38	0.55	V	
		V <sub>IH</sub> = MIN, I <sub>OL</sub> = MAX	±5%V <sub>CC</sub>		0.38	0.55	V	
V <sub>IK</sub>	Input clamp voltage	V <sub>CC</sub> = MIN, I <sub>I</sub> = I <sub>IK</sub>			-0.73	-1.2	V	
I <sub>I</sub>	Input current at maximum input voltage	V <sub>CC</sub> = MAX, V <sub>I</sub> = 7.0V				100	μA	
I <sub>IH</sub>	High-level input current	V <sub>CC</sub> = MAX, V <sub>I</sub> = 2.7V				20	μA	
I <sub>IL</sub>	Low-level input current	V <sub>CC</sub> = MAX, V <sub>I</sub> = 0.5V				-20	μA	
I <sub>O</sub>	Output current <sup>3</sup>	V <sub>CC</sub> = MAX		-60		-180	mA	
I <sub>CC</sub>	Supply current (total)	I <sub>CC</sub> H I <sub>CC</sub> L	V <sub>CC</sub> = MAX	V <sub>IN</sub> = GND		21	30	mA
				V <sub>IN</sub> = 4.5V			31	44

**NOTES:**

- For conditions shown as MIN or MAX, use the appropriate value specified under recommended operating conditions for the applicable type.
- All typical values are at V<sub>CC</sub> = 5V, T<sub>amb</sub> = 25°C.
- The output conditions have been chosen to produce a current that closely approximates one half of the true short-circuit output current, I<sub>OS</sub>.

# Hex 2-input OR drivers

74F832/74F1832

## AC ELECTRICAL CHARACTERISTICS

SYMBOL	PARAMETER	TEST CONDITION	LIMITS					UNIT
			T <sub>amb</sub> = +25°C			T <sub>amb</sub> = 0°C to +70°C		
			V <sub>CC</sub> = +5.0V C <sub>L</sub> = 50pF, R <sub>L</sub> = 500Ω			V <sub>CC</sub> = +5.0V ± 10% C <sub>L</sub> = 50pF, R <sub>L</sub> = 500Ω		
MIN	TYP	MAX	MIN	MAX				
t <sub>PLH</sub> t <sub>PHL</sub>	Propagation delay D <sub>na</sub> , D <sub>nb</sub> to Q <sub>n</sub>	Waveform 1	2.0	4.0	6.0	2.0	6.5	ns
			2.0	3.5	6.0	1.5	6.5	
t <sub>sk(o)</sub>	Output skew <sup>1, 2</sup>	Waveform 2			2.0		2.5	ns

**NOTES:**

1. | t<sub>PN</sub> actual – t<sub>PM</sub> actual | for any output compared to any other output where N and M are either LH or HL.
2. Skew times are valid only under same test conditions (temperature, V<sub>CC</sub>, loading, etc.).

## AC WAVEFORMS

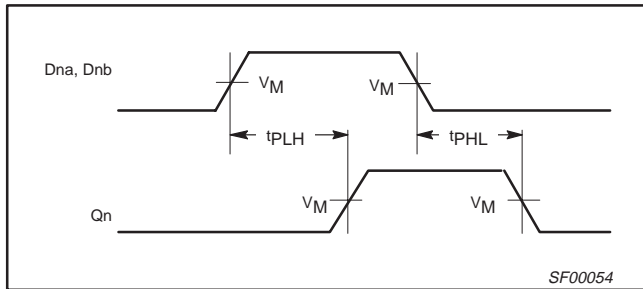

Waveform 1. Propagation delay for inverting output

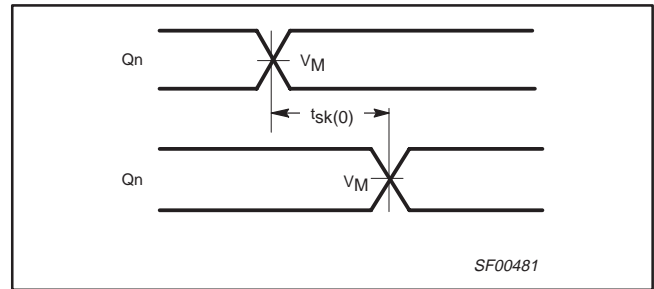

Waveform 2. Output skew

**NOTE:** For all waveforms, V<sub>M</sub> = 1.5V.

## TEST CIRCUIT AND WAVEFORMS

**Test Circuit for Totem-Pole Outputs**

**Input Pulse Definition**

**DEFINITIONS:**

R<sub>L</sub> = Load resistor;  
see AC ELECTRICAL CHARACTERISTICS for value.

C<sub>L</sub> = Load capacitance includes jig and probe capacitance;  
see AC ELECTRICAL CHARACTERISTICS for value.

R<sub>T</sub> = Termination resistance should be equal to Z<sub>OUT</sub> of pulse generators.

family	INPUT PULSE REQUIREMENTS					
	amplitude	V <sub>M</sub>	rep. rate	t <sub>w</sub>	t <sub>TLH</sub>	t <sub>THL</sub>
74F	3.0V	1.5V	1MHz	500ns	2.5ns	2.5ns

SF00006

# Hex 2-input OR drivers

74F832, 74F1832

DIP20: plastic dual in-line package; 20 leads (300 mil)

SOT146-1

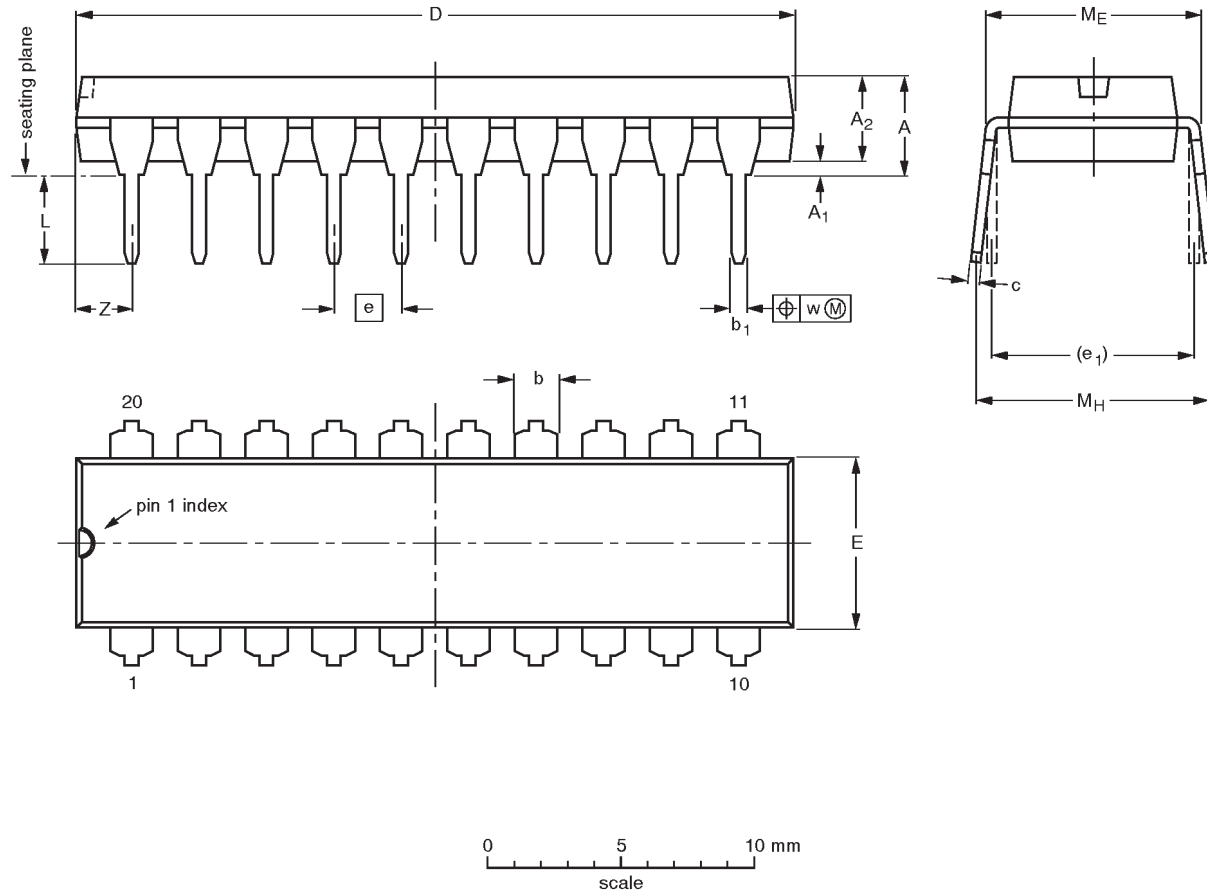

**DIMENSIONS** (inch dimensions are derived from the original mm dimensions)

UNIT	A max.	A <sub>1</sub> min.	A <sub>2</sub> max.	b	b <sub>1</sub>	c	D <sup>(1)</sup>	E <sup>(1)</sup>	e	e <sub>1</sub>	L	M <sub>E</sub>	M <sub>H</sub>	w	Z <sup>(1)</sup> max.
mm	4.2	0.51	3.2	1.73 1.30	0.53 0.38	0.36 0.23	26.92 26.54	6.40 6.22	2.54	7.62	3.60 3.05	8.25 7.80	10.0 8.3	0.254	2.0
inches	0.17	0.020	0.13	0.068 0.051	0.021 0.015	0.014 0.009	1.060 1.045	0.25 0.24	0.10	0.30	0.14 0.12	0.32 0.31	0.39 0.33	0.01	0.078

**Note**

1. Plastic or metal protrusions of 0.25 mm maximum per side are not included.

OUTLINE VERSION	REFERENCES				EUROPEAN PROJECTION	ISSUE DATE
	IEC	JEDEC	EIAJ			
SOT146-1			SC603			92-11-17 95-05-24

# Hex 2-input OR drivers

# 74F832, 74F1832

**SO20:** plastic small outline package; 20 leads; body width 7.5 mm

**SOT163-1**

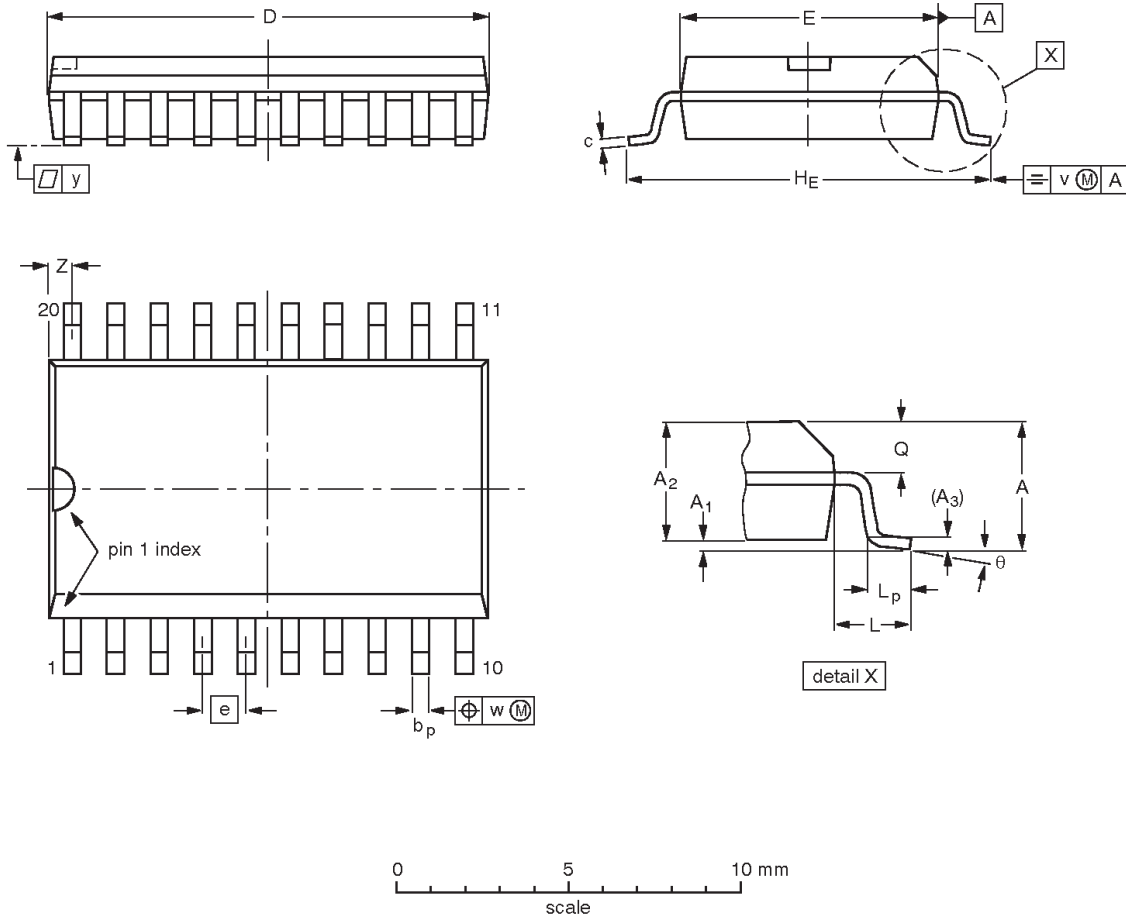

**DIMENSIONS (inch dimensions are derived from the original mm dimensions)**

UNIT	A max.	A <sub>1</sub>	A <sub>2</sub>	A <sub>3</sub>	b <sub>p</sub>	c	D <sup>(1)</sup>	E <sup>(1)</sup>	e	H <sub>E</sub>	L	L <sub>p</sub>	Q	v	w	y	z <sup>(1)</sup>	$\theta$
mm	2.65	0.30 0.10	2.45 2.25	0.25	0.49 0.36	0.32 0.23	13.0 12.6	7.6 7.4	1.27	10.65 10.00	1.4	1.1 0.4	1.1 1.0	0.25	0.25	0.1	0.9 0.4	8° 0°
inches	0.10	0.012 0.004	0.096 0.089	0.01	0.019 0.014	0.013 0.009	0.51 0.49	0.30 0.29	0.050	0.419 0.394	0.055	0.043 0.016	0.043 0.039	0.01	0.01	0.004	0.035 0.016	

**Note**

1. Plastic or metal protrusions of 0.15 mm maximum per side are not included.

OUTLINE VERSION	REFERENCES				EUROPEAN PROJECTION	ISSUE DATE
	IEC	JEDEC	EIAJ			
SOT163-1	075E04	MS-013AC				95-01-24 97-05-22

## Hex 2-input OR drivers

74F832, 74F1832

## Data sheet status

Data sheet status	Product status	Definition [1]
Objective specification	Development	This data sheet contains the design target or goal specifications for product development. Specification may change in any manner without notice.
Preliminary specification	Qualification	This data sheet contains preliminary data, and supplementary data will be published at a later date. Philips Semiconductors reserves the right to make changes at any time without notice in order to improve design and supply the best possible product.
Product specification	Production	This data sheet contains final specifications. Philips Semiconductors reserves the right to make changes at any time without notice in order to improve design and supply the best possible product.

[1] Please consult the most recently issued datasheet before initiating or completing a design.

## Definitions

**Short-form specification** — The data in a short-form specification is extracted from a full data sheet with the same type number and title. For detailed information see the relevant data sheet or data handbook.

**Limiting values definition** — Limiting values given are in accordance with the Absolute Maximum Rating System (IEC 134). Stress above one or more of the limiting values may cause permanent damage to the device. These are stress ratings only and operation of the device at these or at any other conditions above those given in the Characteristics sections of the specification is not implied. Exposure to limiting values for extended periods may affect device reliability.

**Application information** — Applications that are described herein for any of these products are for illustrative purposes only. Philips Semiconductors make no representation or warranty that such applications will be suitable for the specified use without further testing or modification.

## Disclaimers

**Life support** — These products are not designed for use in life support appliances, devices or systems where malfunction of these products can reasonably be expected to result in personal injury. Philips Semiconductors customers using or selling these products for use in such applications do so at their own risk and agree to fully indemnify Philips Semiconductors for any damages resulting from such application.

**Right to make changes** — Philips Semiconductors reserves the right to make changes, without notice, in the products, including circuits, standard cells, and/or software, described or contained herein in order to improve design and/or performance. Philips Semiconductors assumes no responsibility or liability for the use of any of these products, conveys no license or title under any patent, copyright, or mask work right to these products, and makes no representations or warranties that these products are free from patent, copyright, or mask work right infringement, unless otherwise specified.

Philips Semiconductors  
811 East Arques Avenue  
P.O. Box 3409  
Sunnyvale, California 94088-3409  
Telephone 800-234-7381

© Copyright Philips Electronics North America Corporation 1998  
All rights reserved. Printed in U.S.A.

print code

Date of release: 10-98

Document order number:

9397-750-05187

*Let's make things better.*