

MAPX	MODIFICATION	DATE

NOTE:

- Material:
 - Housing: Thermoplastics
 - Contact: Phosphor Bronze C5191-EH/C2680-EH, T=0.25mm
 - Shell: COPPER ALLOY T=0.30mm
- FINISH:
 - Contact: 15u" Gold Plated on Contact Area, 80u" Min.Tin Plated on Solder Area, 50u" Min.Nickel Underplating Over All.
 - Shell: 50u" Min.Nickel Underplating Over All.
- Specification:
 - Rating:
 - Rated voltage 500V AC/DC. Rated current: 2 A Max.
 - Electrical:
 - Insulation Resistance(EIA-364-21): 1000M Ω Min. at 500V/DC for 1Minute.
 - Contact Resistance(EIA-364-23): 30 m Ω Max. at 20mV Max, 50mA
 - Dielectric Withstanding Voltage(EIA-364-20): No discharge, flashover or breakdown at 500V/AC 1Minute
- Plug extraction force shall be between 1.0kgf and 2.00kgf
- Contact finish:
 - 01: Selective Gold Flash
 - 02: Selective Gold 3U"
 - 03: Selective Gold 5U"
 - 04: Selective Gold 15U"
 - 05: Selective Gold 30U"

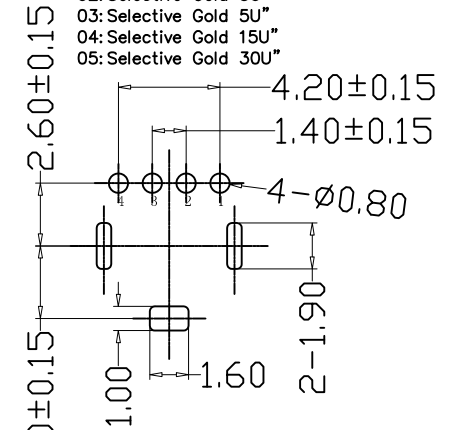
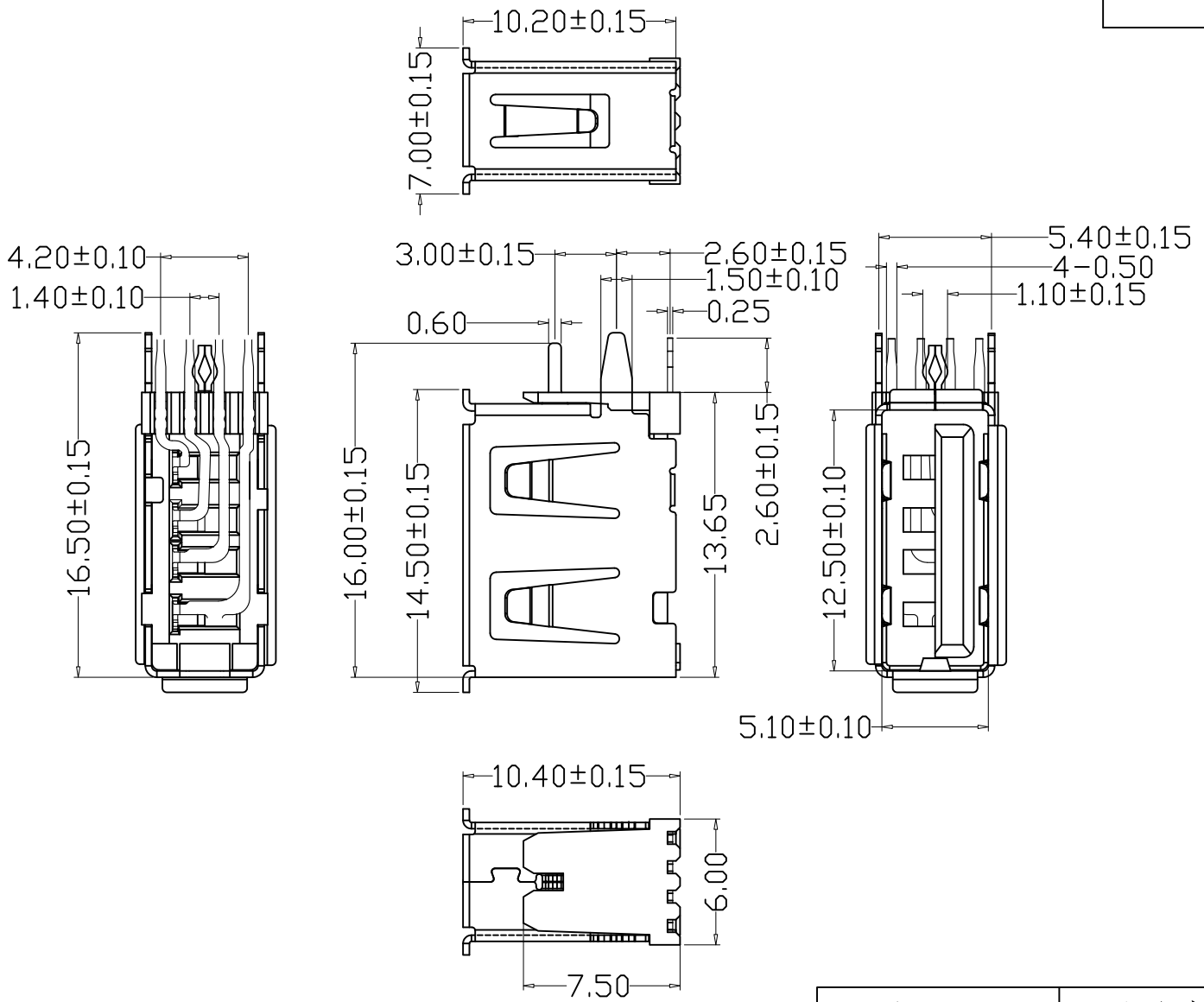

产品图 PRODUCT CHART DWG		深圳市精拓金电子有限公司							
公差一览表 TOLERANCE UNLESS OTHERWISE		单位 UNITS	MM	制图 DRAWING	Z-Y-B	制图料号 PRODUCT PART NO.	906-551A1014D10200		
X.	±0.25	X.	±5.°	比例 SCALE	1:1	审核 CHKD	产品名称 PRODUCT NO.	AF10.0侧插短体外直内O型脚有边铁壳PBT白胶	
.X	±0.20	.X	±2.°	日期 DATE	2014.02.20	核准 APPD	角法 VIEW	版本 VER	AO
.XX	±0.15	.XX	±1.°						
.XXX	±0.10	.XXX	±0.5°						