

DESCRIPTION

The SSF6670 uses advanced trench technology to provide excellent $R_{DS(ON)}$ and low gate charge.

GENERAL FEATURES

- $V_{DS} = 60V, I_D = 3.5A$
- $R_{DS(ON)} < 120m\Omega @ V_{GS}=4.5V$
- $R_{DS(ON)} < 90m\Omega @ V_{GS}=10V$
- High Power and current handling capability
- Lead free product
- Surface Mount Package

APPLICATIONS

- PWM applications
- Load switch
- Power management

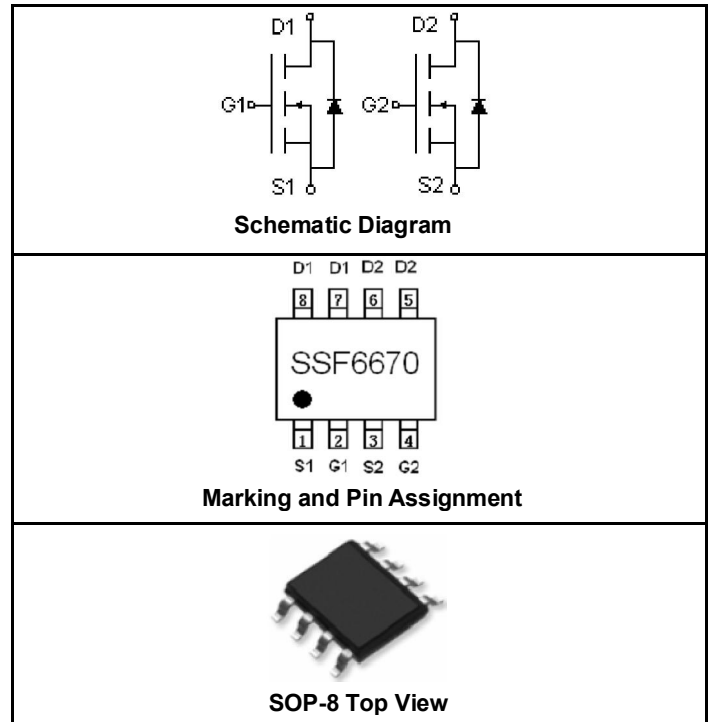

PACKAGE MARKING AND ORDERING INFORMATION

Device Marking	Device	Device Package	Reel Size	Tape Width	Quantity
SSF6670	SSF6670	SOP-8	Ø330mm	12mm	2500 units

ABSOLUTE MAXIMUM RATINGS ($T_A=25^\circ C$ unless otherwise noted)

Parameter	Symbol	Limit	Unit
Drain-Source Voltage	V_{DS}	60	V
Gate-Source Voltage	V_{GS}	± 25	V
Drain Current-Continuous@ Current-Pulsed (Note 1)	$I_D(25^\circ C)$	3.5	A
	$I_D(70^\circ C)$	2.8	A
	I_{DM}	20	A
Maximum Power Dissipation	P_D	2.4	W
Operating Junction and Storage Temperature Range	T_J, T_{STG}	-55 To 175	$^\circ C$

THERMAL CHARACTERISTICS

Thermal Resistance, Junction-to-Ambient (Note 2)	$R_{\theta JA}$	62.5	$^\circ C/W$
--------------------------------------------------	-----------------	------	--------------

ELECTRICAL CHARACTERISTICS ($T_A=25^\circ C$ unless otherwise noted)

Parameter	Symbol	Condition	Min	Typ	Max	Unit
OFF CHARACTERISTICS						
Drain-Source Breakdown Voltage	BV_{DSS}	$V_{GS}=0V, I_D=250\mu A$	60			V



SSF6670

60V Dual N-Channel MOSFET

Zero Gate Voltage Drain Current	I_{DSS}	$V_{DS}=60V, V_{GS}=0V$			10	μA
Gate-Body Leakage Current	I_{GSS}	$V_{GS}=\pm 25V, V_{DS}=0V$			± 100	nA
ON CHARACTERISTICS (Note 3)						
Gate Threshold Voltage	$V_{GS(th)}$	$V_{DS}=V_{GS}, I_D=250\mu A$	1		3	V
Drain-Source On-State Resistance	$R_{DS(ON)}$	$V_{GS}=4.5V, I_D=2A$		80	120	m Ω
		$V_{GS}=10V, I_D=3A$		65	90	m Ω
Forward Transconductance	g_{FS}	$V_{DS}=10V, I_D=3A$	3			S
DYNAMIC CHARACTERISTICS (Note4)						
Input Capacitance	C_{ISS}	$V_{DS}=25V, V_{GS}=0V,$ $F=1.0MHz$		500		PF
Output Capacitance	C_{OSS}			50		PF
Reverse Transfer Capacitance	C_{RSS}			40		PF
SWITCHING CHARACTERISTICS (Note 4)						
Turn-on Delay Time	$t_{d(on)}$	$V_{DS}=30V, V_{GS}=10V, R_{GEN}=3\Omega$ $I_D=1A$		6		nS
Turn-on Rise Time	t_r			5		nS
Turn-Off Delay Time	$t_{d(off)}$			16		nS
Turn-Off Fall Time	t_f			3		nS
Total Gate Charge	Q_g	$V_{DS}=48V, I_D=3A, V_{GS}=4.5V$		7		nC
Gate-Source Charge	Q_{gs}			2		nC
Gate-Drain Charge	Q_{gd}			3		nC
Body Diode Reverse Recovery Time	T_{rr}	$I_F=4A, di/dt=100A/\mu s$		27		nS
Body Diode Reverse Recovery Charge	Q_{rr}			32		nC
DRAIN-SOURCE DIODE CHARACTERISTICS						
Diode Forward Voltage (Note 3)	V_{SD}	$V_{GS}=0V, I_S=1.7A$			1.2	V

NOTES:

1. Repetitive Rating: Pulse width limited by maximum junction temperature.
2. Surface Mounted on 1in² FR4 Board, $t \leq 10$ sec.
3. Pulse Test: Pulse Width $\leq 300\mu s$, Duty Cycle $\leq 2\%$.
4. Guaranteed by design, not subject to production testing.

TYPICAL ELECTRICAL AND THERMAL CHARACTERISTICS

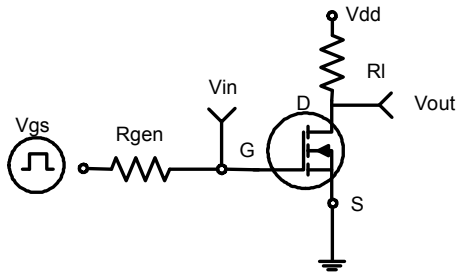

Figure 1: Switching Test Circuit

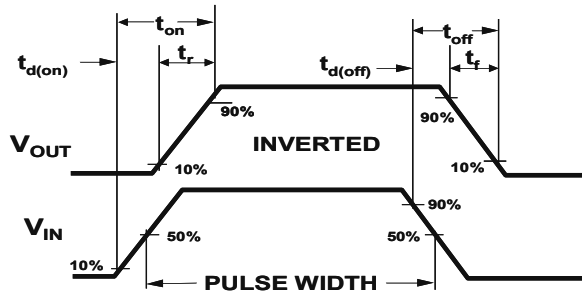

Figure 2: Switching Waveforms

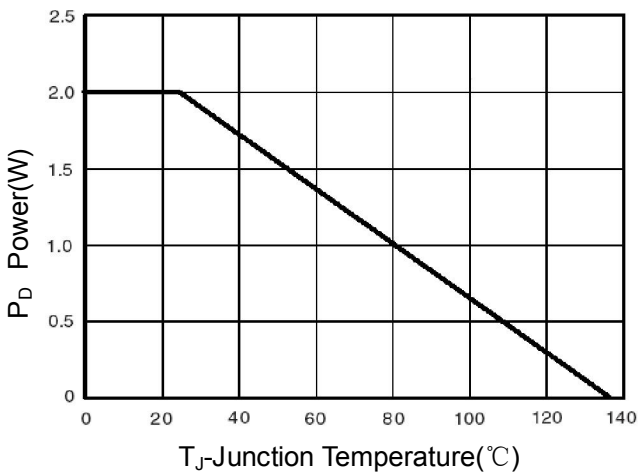

Figure 3 Power Dissipation

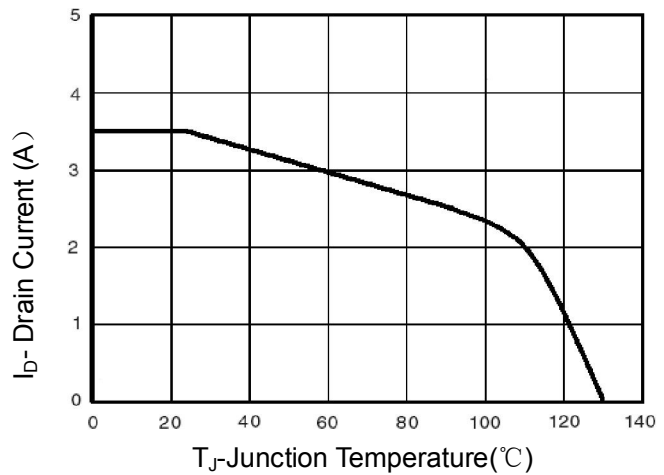

Figure 4 Drain Current

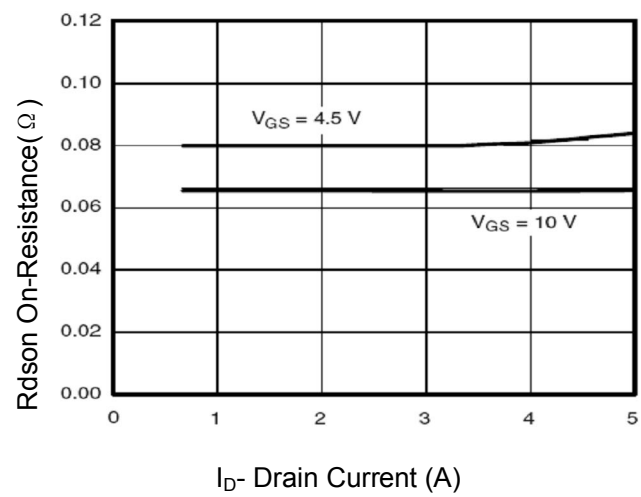
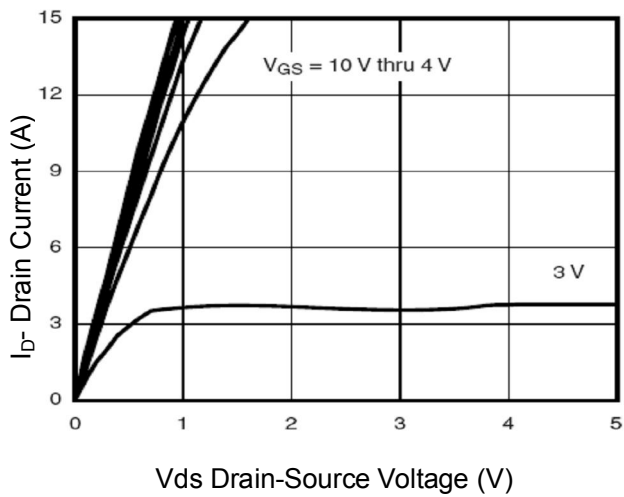

Figure 5 Output CHARACTERISTICS

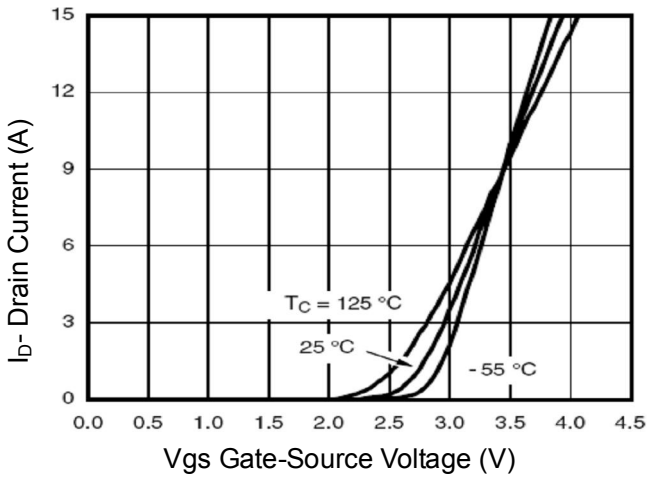

Figure 7 Transfer Characteristics

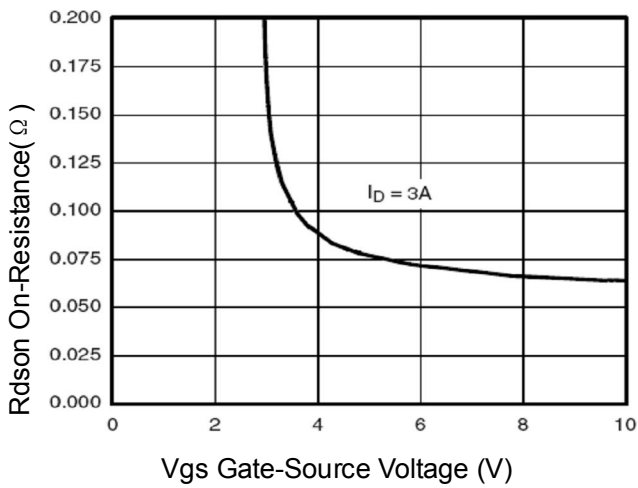

Figure 9 Rdson vs Vgs

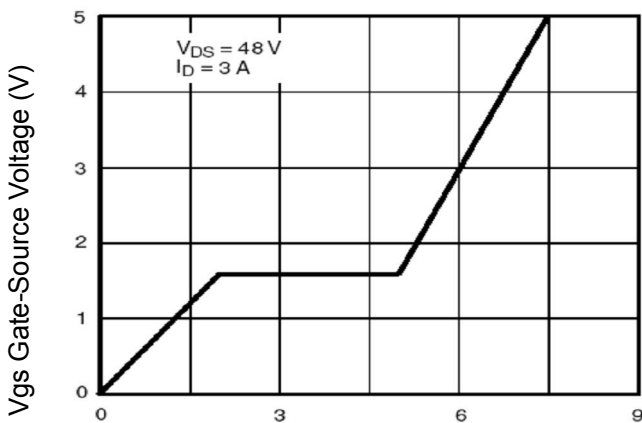

Figure 6 Drain-Source On-Resistance

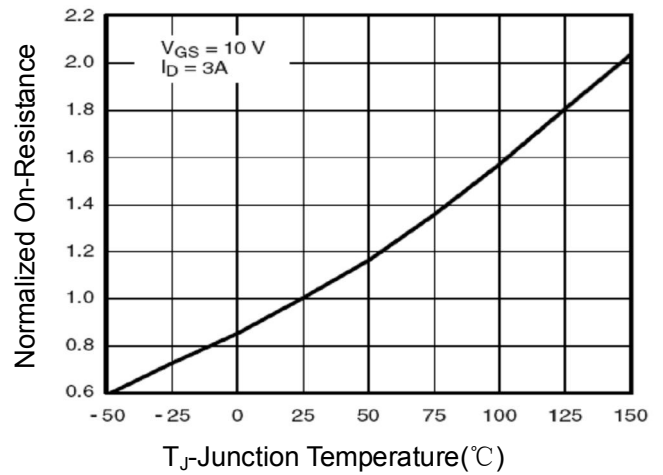

Figure 8 Drain-Source On-Resistance

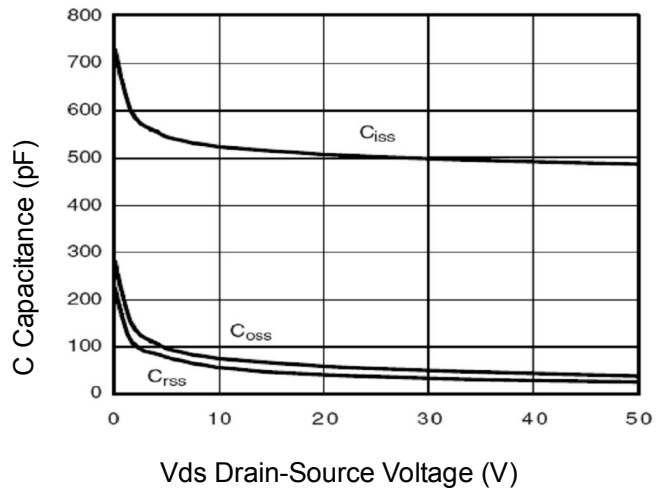
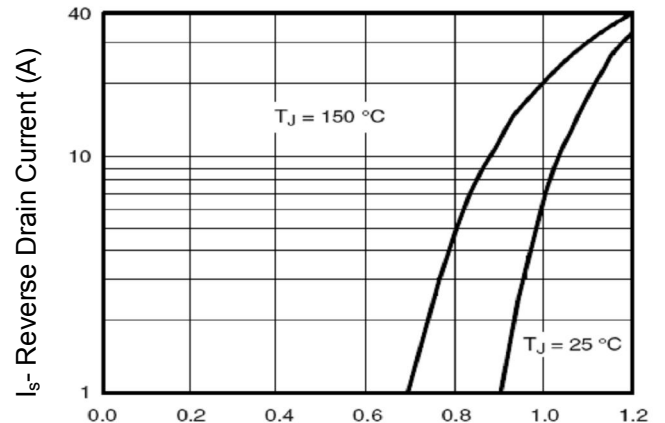

Figure 10 Capacitance vs Vds



Qg Gate Charge (nC)
Figure 11 Gate Charge

Vsd Source-Drain Voltage (V)
Figure 12 Source- Drain Diode Forward

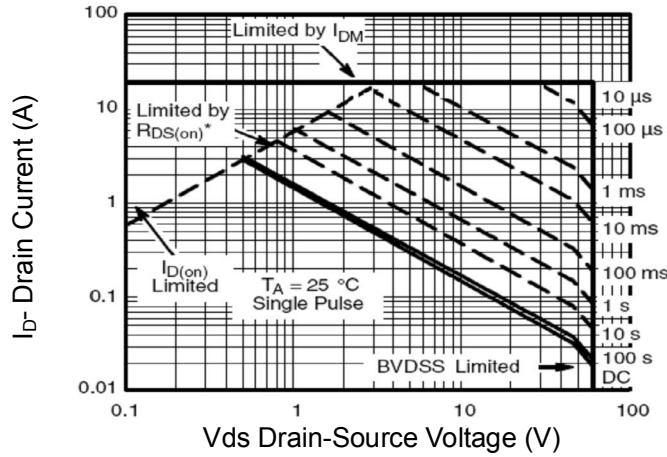

Figure 13 Safe Operation Area

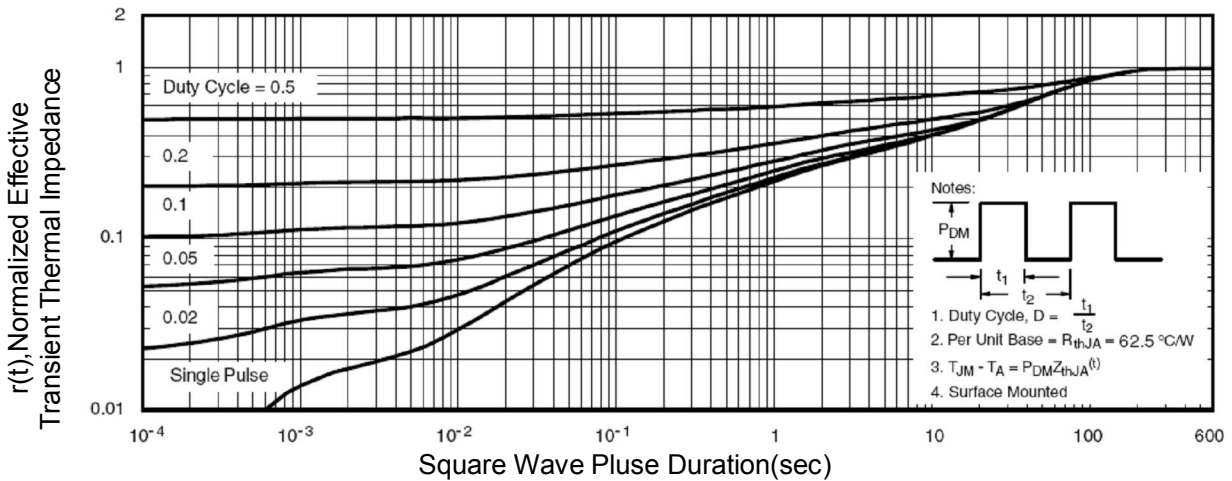
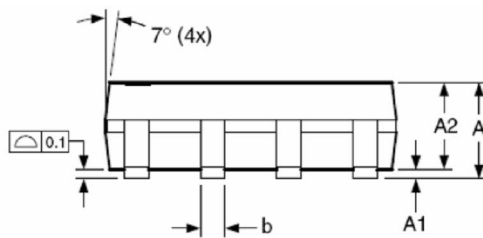
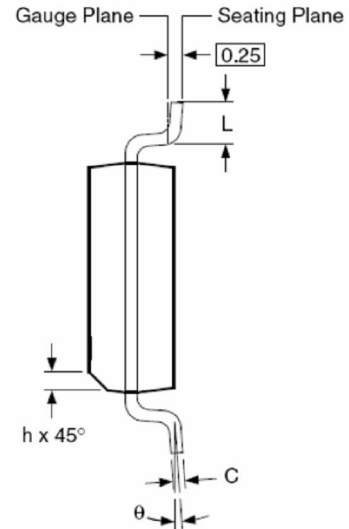
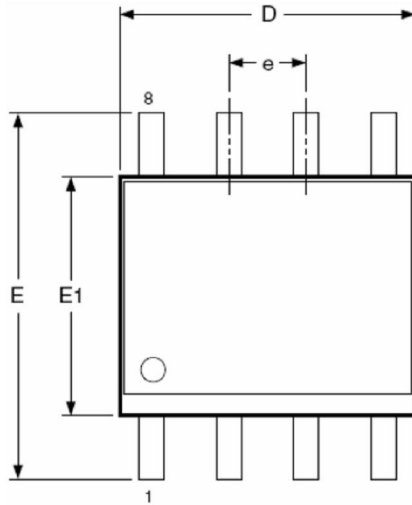
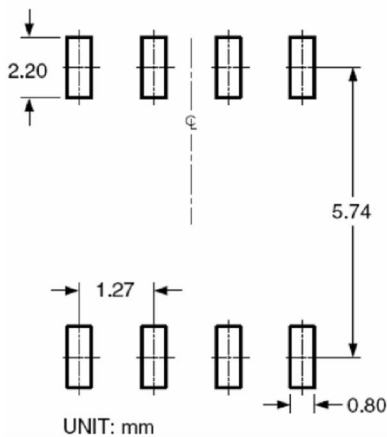

Figure 14 Normalized Maximum Transient Thermal Impedance

SOP-8 PACKAGE INFORMATION



RECOMMENDED LAND PATTERN



Dimensions in millimeters

Symbols	Min.	Nom.	Max.
A	1.35	1.65	1.75
A1	0.10	—	0.25
A2	1.25	1.50	1.65
b	0.31	—	0.51
c	0.17	—	0.25
D	4.80	4.90	5.00
E1	3.80	3.90	4.00
e	1.27 BSC		
E	5.80	6.00	6.20
h	0.25	—	0.50
L	0.40	—	1.27
θ	0°	—	8°

Dimensions in inches

Symbols	Min.	Nom.	Max.
A	0.053	0.065	0.069
A1	0.004	—	0.010
A2	0.049	0.059	0.065
b	0.012	—	0.020
c	0.007	—	0.010
D	0.189	0.193	0.197
E1	0.150	0.154	0.157
e	0.050 BSC		
E	0.228	0.236	0.244
h	0.010	—	0.020
L	0.016	—	0.050
θ	0°	—	8°

NOTES:

1. Dimensions are inclusive of plating
2. Package body sizes exclude mold flash and gate burrs. Mold flash at the non-lead sides should be less than 6 mils.
3. Dimension L is measured in gauge plane.
4. Controlling dimension is millimeter, converted inch dimensions are not necessarily exact.