

## FEATURES

- 1、Low profile construction and miniature size
- 2、Magnetic shielded construction .
- 3、High current saturation.
- 4、For new generation portable product DC/DC converter unit.

## APPLICATIONS

DVD、Set-Top Box、DSC PDA、LCD display Cellular phones, HDD, etc.

## PRODUCT IDENTIFICATION

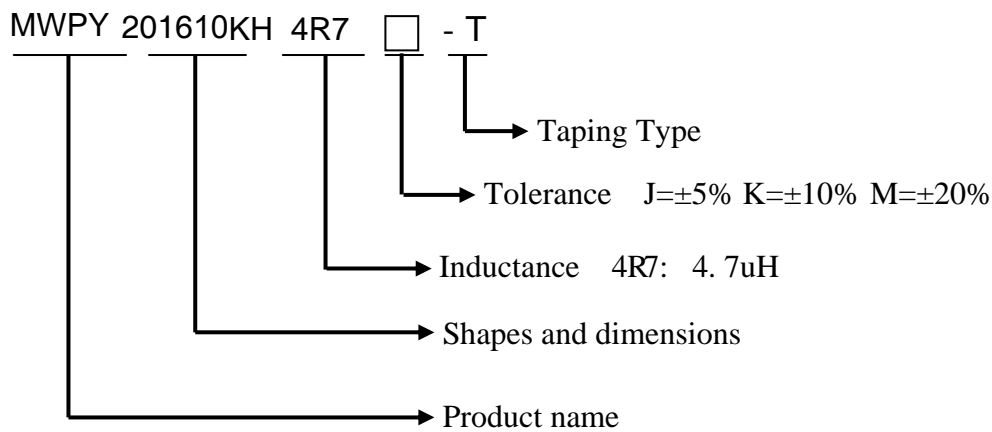

## SHAPES AND DIMENSIONS(Unit:mm)

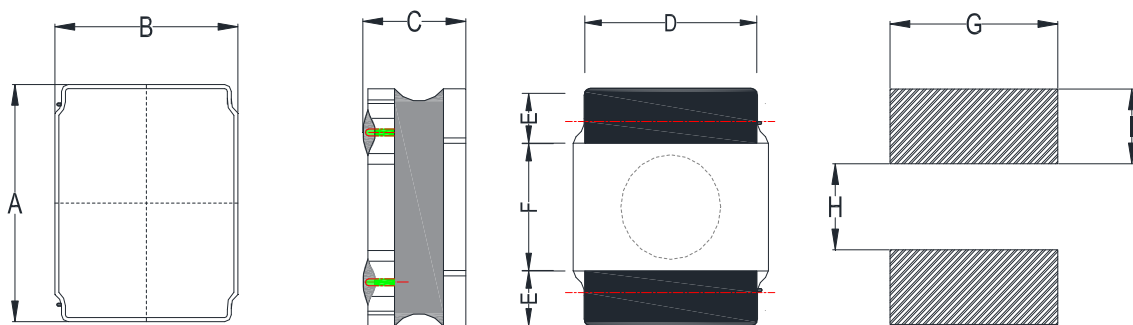

A	B	C	D	E	F	G	H	I
2.0 ± 0.2	1.6 ± 0.2	1.08Max	1.6 ± 0.2	0.6 ± 0.2	0.8 ± 0.2	1.60	0.80	0.80

## ELECTRICAL CHARACTERISTICS

Part Number	Inductance	DC Resistance		Saturation Current		Heat Rating Current	
	1MHz/1V	Max.	Typ.	Max.	Typ.	Max.	Typ.
Units	uH	$\Omega$	$\Omega$	A	A	A	A
Symbol	L	DCR		Isat		Irms	
MWPY201610KH-R24-M-T	0.24 $\pm$ 20%	0.040	0.033	4.50	5.50	3.00	3.45
MWPY201610KH-R33-M-T	0.33 $\pm$ 20%	0.049	0.041	4.40	5.20	2.70	3.10
MWPY201610KH-R47-M-T	0.47 $\pm$ 20%	0.049	0.041	4.06	4.70	2.70	3.10
MAI20161010KH-R56-M-T	0.56 $\pm$ 20%	0.053	0.043	3.80	4.50	2.60	2.80
MWPY201610KH-R68-M-T	0.68 $\pm$ 20%	0.065	0.057	3.50	4.00	2.50	2.80
MWPY201610KH-1R0-M-T	1.0 $\pm$ 20%	0.095	0.078	3.30	3.80	2.00	2.30
MWPY201610KH-1R5-M-T	1.5 $\pm$ 20%	0.130	0.110	1.95	2.30	1.70	2.00
MWPY201610KH-2R2-M-T	2.2 $\pm$ 20%	0.180	0.160	1.90	2.15	1.40	1.60
MWPY201610KH-3R3-M-T	3.3 $\pm$ 20%	0.307	0.245	1.40	1.60	1.10	1.30
MWPY201610KH-4R7-M-T	4.7 $\pm$ 20%	0.425	0.370	1.10	1.40	0.90	1.00
MWPY201610KH-6R8-M-T	6.8 $\pm$ 20%	0.620	0.500	0.95	1.10	0.70	0.82
MWPY201610KH-8R2-M-T	8.2 $\pm$ 20%	0.870	0.670	0.86	1.00	0.66	0.76
MWPY201610KH-100-M-T	10 $\pm$ 20%	0.875	0.700	0.80	0.95	0.60	0.70
MWPY201610KH-150-M-T	15 $\pm$ 20%	1.70	1.30	0.69	0.75	0.36	0.42

Note:※1: Rated current: Isat(max.)or Irms(max.),whichever is smaller;

※2: Saturation Current: Max. Value, DC current at which the inductance drops less than 30% from its value without current; Typ. Value, DC current at which the inductance drops 30% from its value without current;

※3: Irms: DC current that causes the temperature rise ( $\Delta T$ ) from 20 $^{\circ}$ C ambient.

For Max. Value,  $\Delta T < 40^{\circ}$ C; for Typ. Value,  $\Delta T$  is approximate 40 $^{\circ}$ C.

The part temperature (ambient + temp. rise) should not exceed 125 $^{\circ}$ C under worst case operating conditions. Circuit design, component placement, PCB trace size and thickness, airflow and other cooling provisions all affect the part temperature. Part temperature should be verified in the end application.

※4: Absolute maximum voltage: DC 40V

Typical Electrical Characteristics: Please refer to appendix

## PACKAGING AND DIMENSIONS

### 1. Carrier Tape Dimensions:

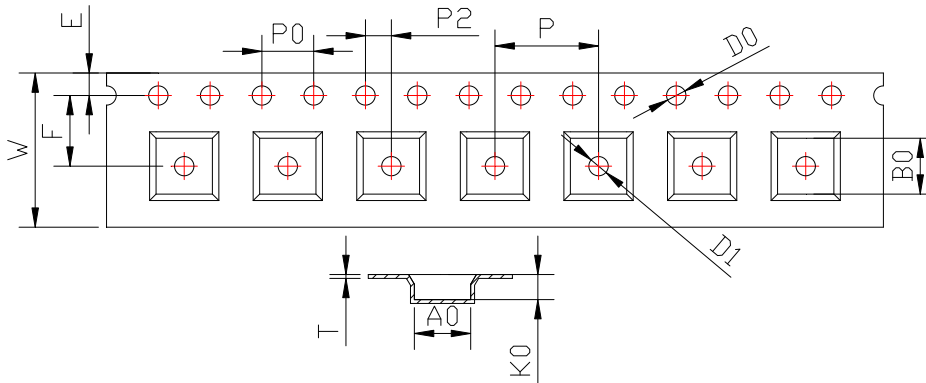

ITEM	W	A0	B0	K0	P	F	E	D0	P0	P2	T
DIM	8.00	2.00	2.40	1.20	4.00	3.5	1.75	1.50	4.00	2.00	0.25
TOLE	±0.3	±0.1	±0.1	±0.1	±0.1	±0.1	±0.1	+0.1	±0.1	±0.1	±0.05

### 2. Taping Dimensions:

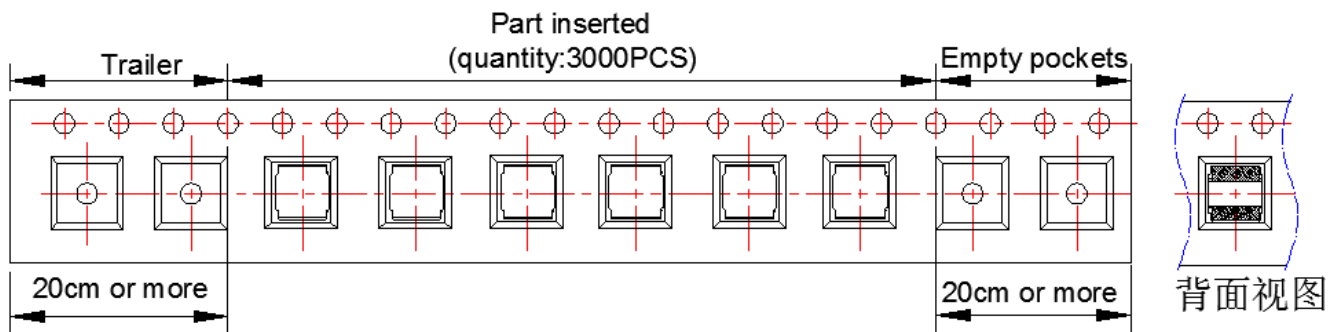

### 3. Reel Dimensions:

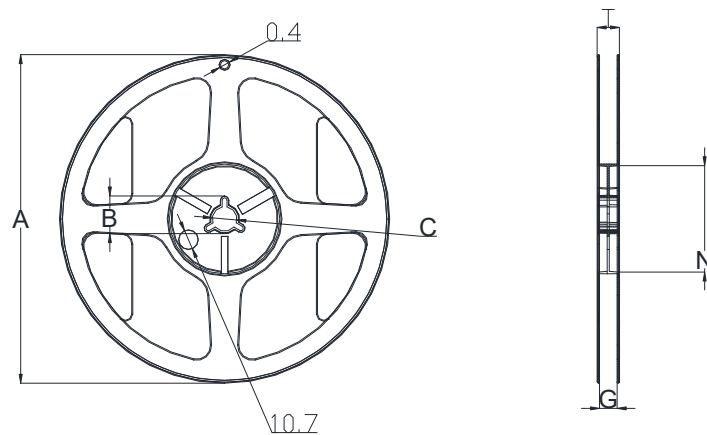

Type	A	B	C	G	N	T
8mm	178	20.7±0.8	13±0.4	9	60	10.8

### 4. Packaging Quantity:

2KPCS/ Reel

**Reliability test :**

NO	Test item	Specification	Test condition	
1-1	High Temperature Exposure	1. No mechanical and electrical damage. 2. Inductance shall not change more than $\pm 20\%$ .	1. Temperature: 125°C. 2. Time: 96 hours.	
1-2	Temperature Cycling		1. Temperature: -40°C ~ +125°C. 2. Cycles: 96. 3. Dwell time: 30 minutes.	
1-3	Biased Humidity		1. Temperature: 85°C. 2. Humidity: 85%RH. 3. Time: 96 hours.	
1-4	Operational Life		1. Temperature: 125°C (Temp. rise included.). 2. Time: 96 hours.	
1-5	Vibration Test		1. Frequency: 10-2000-10 Hz 2. Test duration: 2 hours for each direction, 6 hours in total. 3. Direction: X, Y, Z	
1-6	Resistance To Soldering Heat Test		1. Method: DIP 2. Temperature: 260 $\pm$ 5 3. Time ( $\geq 260^\circ\text{C}$ ): 10 Second 4. Number of times: 3	
1-7	Over Load		Applied double current of Isat to inductor for a period of 5 minutes.	
1-8	Solderability Test		The terminal shall be at least 95% covered with fresh solder.	Dip pads in flux then dip in solder pot at 240 $\pm$ 5 for 5 seconds.
1-9	Withstanding Voltage Test		1. During the test no breakdown. 2. The characteristic is normal after test.	1. DV: 500V 2. Time: 1 minutes
1-10	Terminal Strength Test		Terminals to withstand the pull of at least want to 1.0 kgf.	1. Pull $\geq 1.0$ kgf. 2. Dwell time: 1 minutes

**Recommended Lead-Free IR Reflow Conditions :**

