

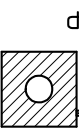

a



d

f

1 2 3 4 5 6 7 8

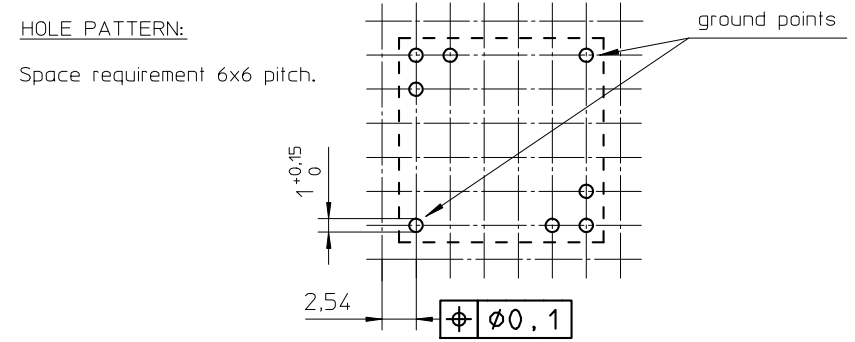
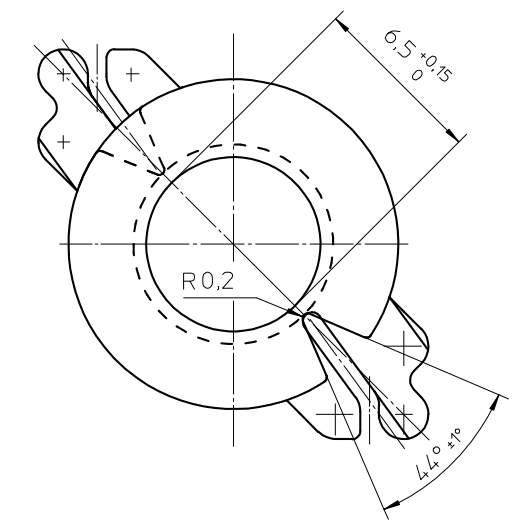
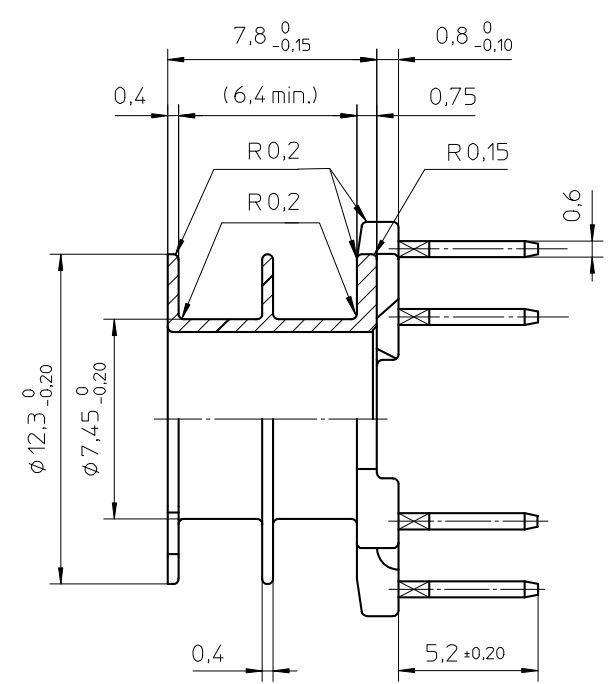
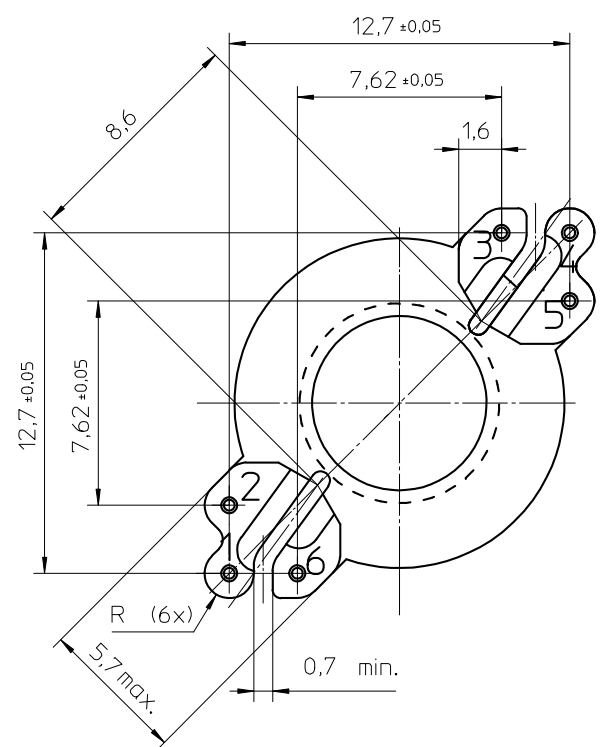

Coil former material: Sumikon PM-9630 (PF), glass-reinforced.
UL file number: E41429 - UL94V-0.

Pin material: CuSn - Ni flash, Sn plated.

Max. operating temp.: acc. to IEC 85 class H, 180°C.

Resistance to soldering heat: acc. to IEC 68-2-20 Part 2, Test Tb, method 1B, 350°C - 3,5s.

Solderability: acc. to IEC 68-2-20 Part 2, Test Ta, method 1, 235°C - 2s.

Min. winding area: 14 mm².

Mean length of turn: 30 mm.

CLASSNO.		CSV-RM6R-2S-6P-IZ		4322 021 06921		07-11-08	
NAME NAAM	A. Waitasz	SUPERS. VERV.	1	SP/SH BL/BL	112 - 001	010	A3
MPA	CHECK CONTR.	DAT.	07-11-08	Property of Eigendom van	© FERROXCUBE 2007		

1 2 3 4