

TC4521BP

TC4521BP 24-Stage Frequency Divider

TC4521BP is frequency divider consisting of 24 stages of flip-flop. The input section is equipped with an inverter to enable to use either RC oscillator circuit or crystal oscillator circuit and to accept pulse from external clock source.

Each flip-flop is inverted by the falling edge of the output of previous stage flip-flop and this can count up to the maximum of $2^{24} = 16,777,216$.

Since six outputs, 2^{18} , 2^{19} , 2^{20} , 2^{21} , 2^{22} , and 2^{23} are available besides of 2^{24} , adjustment of frequency divided output can be achieved.

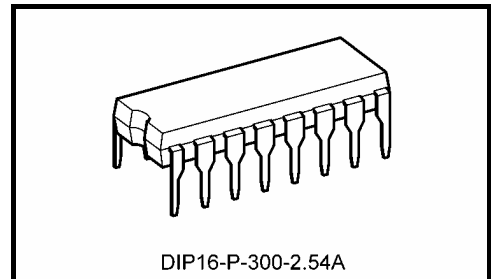

Weight: 1.00 g (typ.)

Pin Assignment

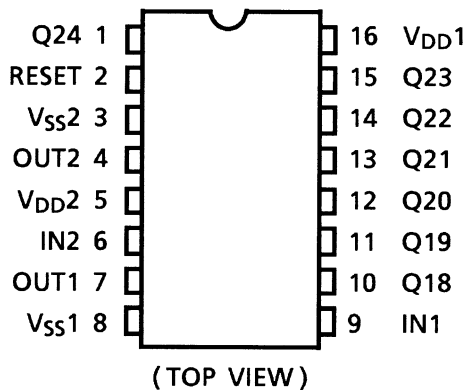

Count Capacity

Output	Count Capacity
Q18	$2^{18} = 262,144$
Q19	$2^{19} = 524,288$
Q20	$2^{20} = 1,048,576$
Q21	$2^{21} = 2,097,152$
Q22	$2^{22} = 4,194,304$
Q23	$2^{23} = 8,388,608$
Q24	$2^{24} = 16,777,216$

Block Diagram

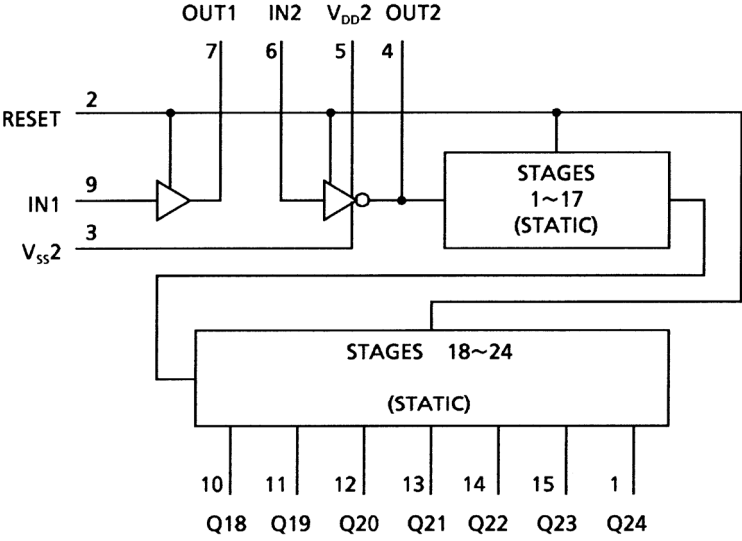

Logic Diagram

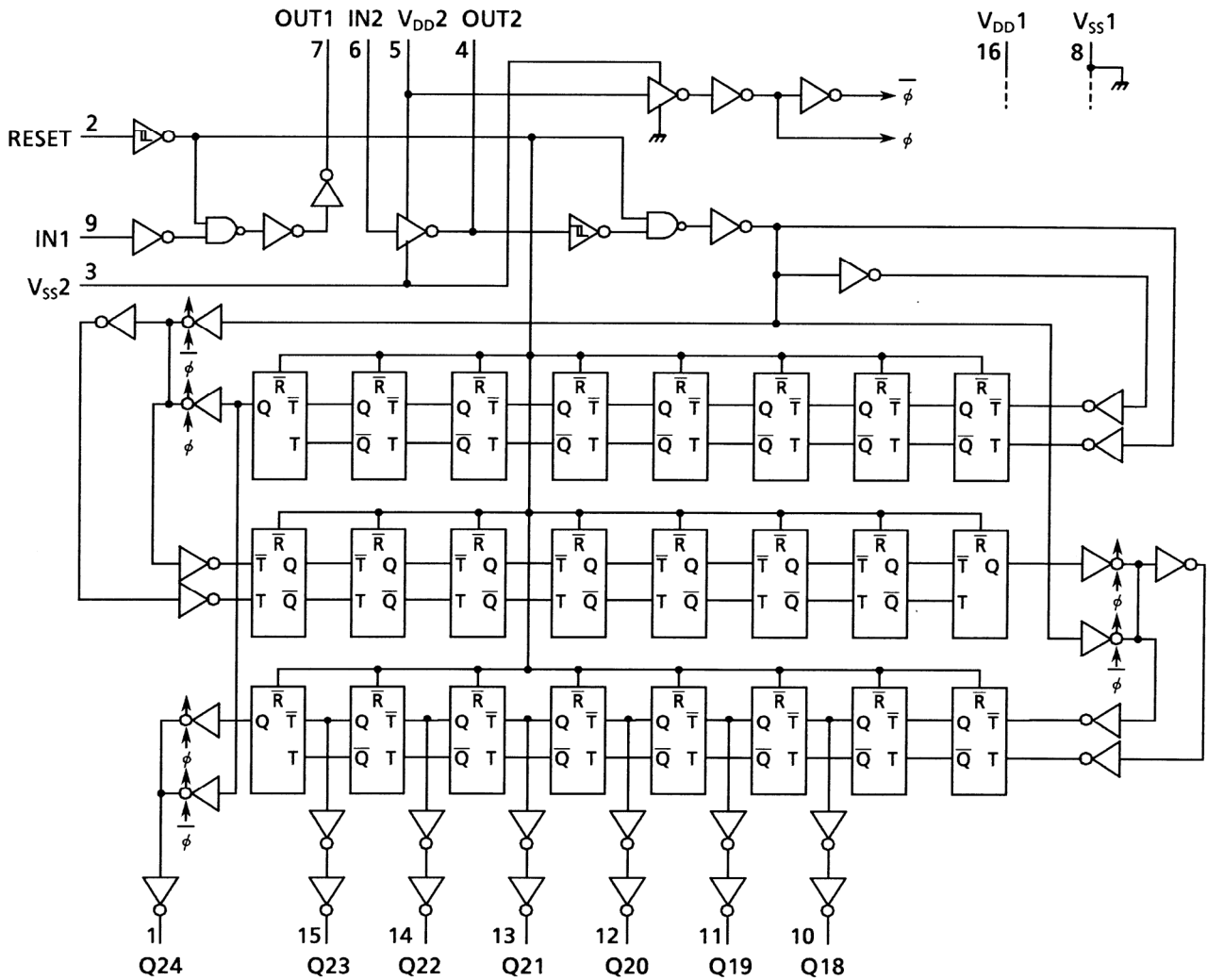

Internal Flip Flop Logic Diagram

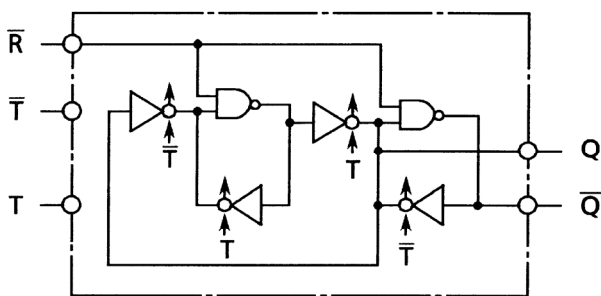

Flip Flop Timing Chart

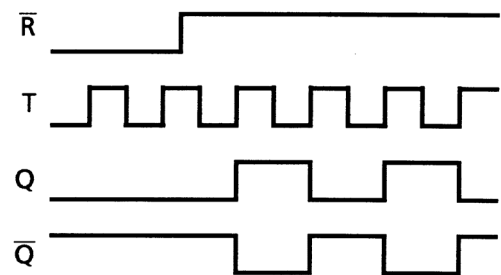

Absolute Maximum Ratings (Note)

Characteristics	Symbol	Rating	Unit
DC supply voltage	V _{DD1}	V _{SS1} - 0.5~V _{SS1} + 20	V
	V _{DD2}	V _{SS1} - 0.5~V _{DD1} + 0.5	
Input voltage	V _{IN}	V _{SS1} - 0.5~V _{DD1} + 0.5	V
Output voltage	V _{OUT}	V _{SS1} - 0.5~V _{DD1} + 0.5	V
DC input current	I _{IN}	±10	mA
Power dissipation	P _D	300	mW
Operating temperature range	T _{opr}	-40~85	°C
Storage temperature range	T _{stg}	-65~150	°C

Note: Exceeding any of the absolute maximum ratings, even briefly, lead to deterioration in IC performance or even destruction.

Using continuously under heavy loads (e.g. the application of high temperature/current/voltage and the significant change in temperature, etc.) may cause this product to decrease in the reliability significantly even if the operating conditions (i.e. operating temperature/current/voltage, etc.) are within the absolute maximum ratings and the operating ranges.

Please design the appropriate reliability upon reviewing the Toshiba Semiconductor Reliability Handbook ("Handling Precautions"/"Derating Concept and Methods") and individual reliability data (i.e. reliability test report and estimated failure rate, etc).

Operating Ranges (V_{SS1} = V_{SS2} = 0 V) (Note)

Characteristics	Symbol	Test Condition	Min	Typ.	Max	Unit
DC supply voltage	V _{DD1} , V _{DD2}	—	3	—	18	V
Input voltage	V _{IN}	—	0	—	V _{DD1}	V

Note: The operating ranges must be maintained to ensure the normal operation of the device. Unused inputs must be tied to either V_{DD} or V_{SS}.

Static Electrical Characteristics (V_{SS1} = V_{SS2} = 0 V, V_{DD1} = V_{DD2})

Characteristics	Sym- bol	Test Condition	V _{DD} (V)	-40°C		25°C			85°C		Unit	
				Min	Max	Min	Typ.	Max	Min	Max		
High-level output voltage	V _{OH}	I _{OUT} < 1 μA V _{IN} = V _{SS} , V _{DD}	5	4.95	—	4.95	5.00	—	4.95	—	V	
			10	9.95	—	9.95	10.00	—	9.95	—		
			15	14.95	—	14.95	15.00	—	14.95	—		
Low-level output voltage	V _{OL}	I _{OUT} < 1 μA V _{IN} = V _{SS} , V _{DD}	5	—	0.05	—	0.00	0.05	—	0.05	V	
			10	—	0.05	—	0.00	0.05	—	0.05		
			15	—	0.05	—	0.00	0.05	—	0.05		
Output high current	I _{OH}	V _{OH} = 4.6 V V _{OH} = 2.5 V V _{OH} = 9.5 V V _{OH} = 13.5 V V _{IN} = V _{SS} , V _{DD}	5	-0.61	—	-0.51	-1.0	—	-0.42	—	mA	
			5	-2.5	—	-2.1	-4.0	—	-1.7	—		
			10	-1.5	—	-1.3	-2.2	—	-1.1	—		
			15	-4.0	—	-3.4	-9.0	—	-2.8	—		
Output low current	I _{OL}	V _{OL} = 0.4 V V _{OL} = 0.5 V V _{OL} = 1.5 V V _{IN} = V _{SS} , V _{DD}	5	0.61	—	0.51	1.2	—	0.42	—	mA	
			10	1.5	—	1.3	3.2	—	1.1	—		
			15	4.0	—	3.4	12.0	—	2.8	—		
Input high voltage	V _{IH}	V _{OUT} = 0.5 V, 4.5 V V _{OUT} = 1.0 V, 9.0 V V _{OUT} = 1.5 V, 13.5 V I _{OUT} < 1 μA	5	3.5	—	3.5	2.75	—	3.5	—	V	
			10	7.0	—	7.0	5.5	—	7.0	—		
			15	11.0	—	11.0	8.25	—	11.0	—		
Input low voltage	V _{IL}	V _{OUT} = 0.5 V, 4.5 V V _{OUT} = 1.0 V, 9.0 V V _{OUT} = 1.5 V, 13.5 V I _{OUT} < 1 μA	5	—	1.5	—	2.25	1.5	—	1.5	V	
			10	—	3.0	—	4.5	3.0	—	3.0		
			15	—	4.0	—	6.75	4.0	—	4.0		
Input current	"H" level	I _{IH}	V _{IH} = 18 V	18	—	0.1	—	10 ⁻⁵	0.1	—	1.0	μA
	"L" level	I _{IL}	V _{IL} = 0 V	18	—	-0.1	—	-10 ⁻⁵	-0.1	—	-1.0	
Quiescent supply current	I _{DD}	V _{IN} = V _{SS} , V _{DD} (Note)	5	—	5	—	0.005	5	—	150	μA	
			10	—	10	—	0.010	10	—	300		
			15	—	20	—	0.015	20	—	600		

Note: All valid input combinations.

Dynamic Electrical Characteristics

($T_a = 25^\circ\text{C}$, $V_{SS1} = V_{SS2} = 0\text{ V}$, $V_{DD1} = V_{DD2}$, $C_L = 50\text{ pF}$)

Characteristics	Symbol	Test Condition	V _{DD} (V)	Min	Typ.	Max	Unit
Output transition time (low to high)	t _{TLH}	—	5	—	70	200	ns
			10	—	35	100	
			15	—	30	80	
Output transition time (high to low)	t _{THL}	—	5	—	70	200	ns
			10	—	35	100	
			15	—	30	80	
Propagation delay time (IN2-Q18)	t _{pLH} t _{pHL}	—	5	—	1.1	9.0	μs
			10	—	0.5	3.5	
			15	—	0.3	2.7	
Propagation delay time (IN2-Q24)	t _{pLH} t _{pHL}	—	5	—	1.4	12	μs
			10	—	0.6	4.5	
			15	—	0.4	3.5	
Propagation delay time (RESET-Qn)	t _{pHL}	—	5	—	220	2600	ns
			10	—	100	1000	
			15	—	70	750	
Max clock frequency	f _{CL}	—	5	3	9.5	—	MHz
			10	6	17.5	—	
			15	8	23.5	—	
Max clock input rise time Max clock input fall time	t _{rCL} t _{fCL}	—	5	No limit			μs
			10				
			15				
Min clock pulse width	t _w	—	5	—	55	385	ns
			10	—	25	150	
			15	—	16	120	
Min pulse width (RESET)	t _{WH}	—	5	—	60	385	ns
			10	—	26	150	
			15	—	20	120	
Input capacitance	C _{IN}	—	—	5	7.5	pF	

Waveforms for Measurement of Dynamic Characteristics

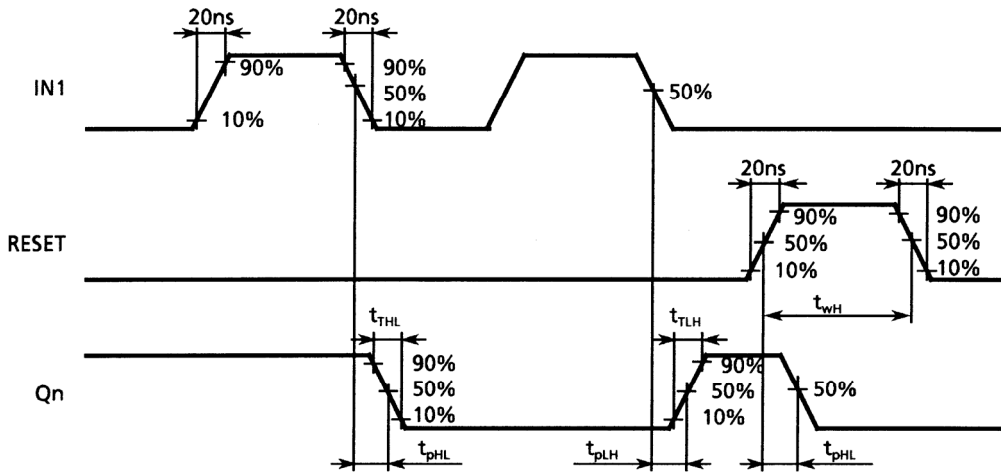

Application Circuit

When CR Oscillation is Used as Time Reference

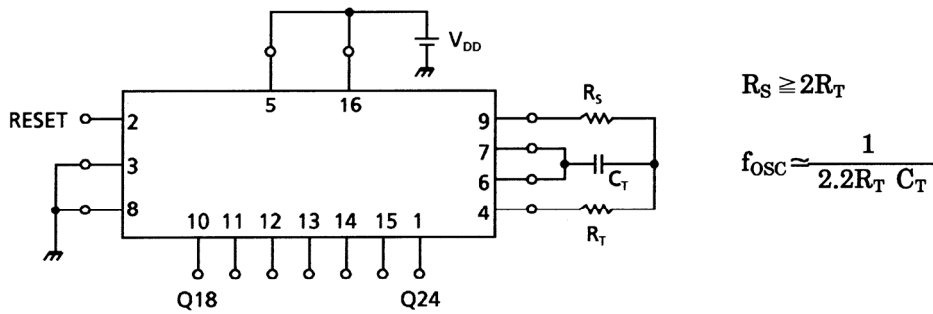

When Crystal Oscillation is Used as the Time Reference

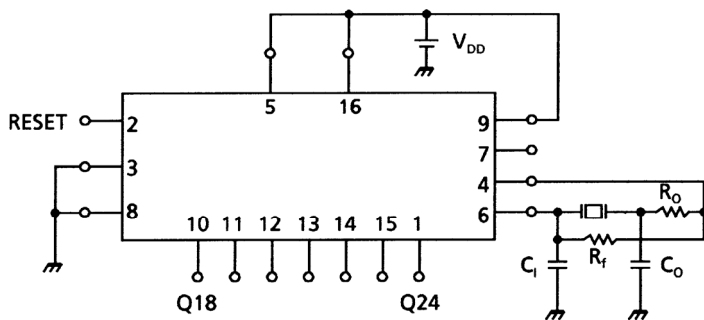

Typical Data

X'tal (Hz)	C ₁ , C ₀ (pF)	R ₀ (Ω)
32.768 k	23	500 k
100 k	60	100 k
1 M	45~50	100
4.194304 M	12~15	0

R_f = 10 MΩ

Package Dimensions

DIP16-P-300-2.54A

Unit : mm

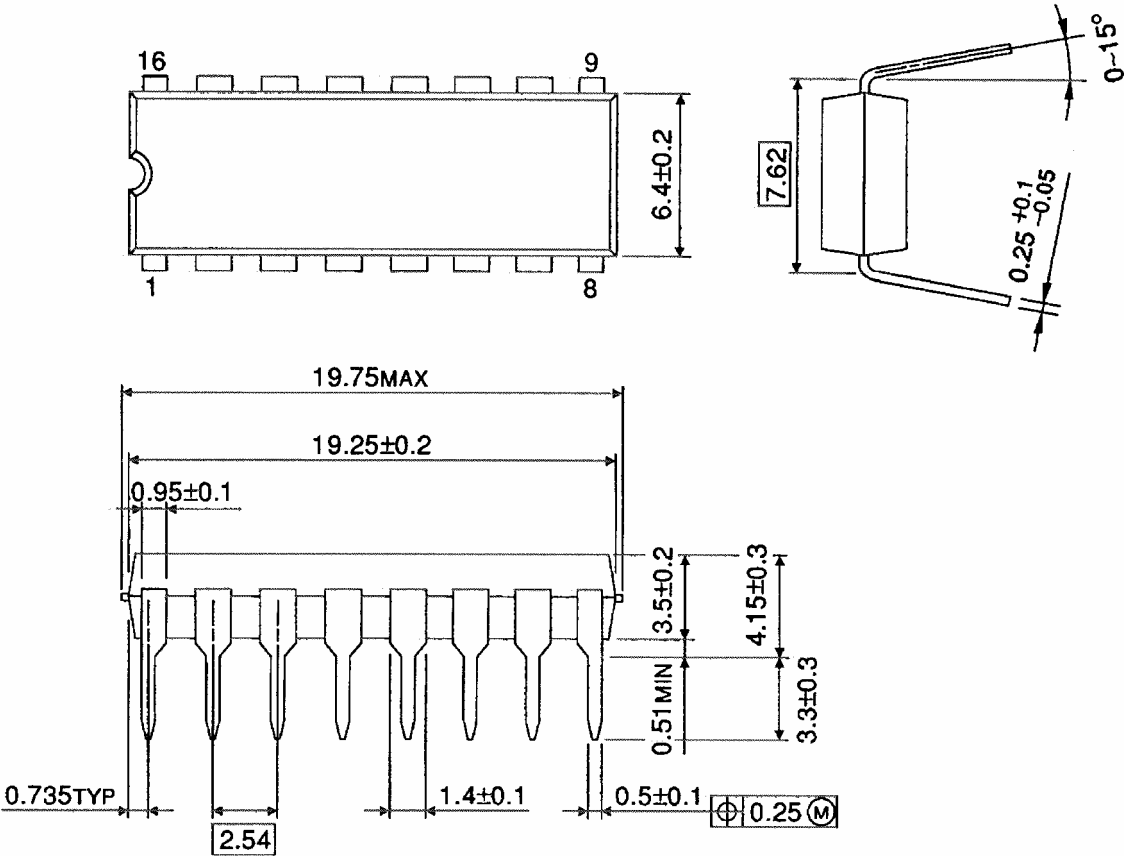

Weight: 1.00 g (typ.)

RESTRICTIONS ON PRODUCT USE

20070701-EN GENERAL

- The information contained herein is subject to change without notice.
- TOSHIBA is continually working to improve the quality and reliability of its products. Nevertheless, semiconductor devices in general can malfunction or fail due to their inherent electrical sensitivity and vulnerability to physical stress. It is the responsibility of the buyer, when utilizing TOSHIBA products, to comply with the standards of safety in making a safe design for the entire system, and to avoid situations in which a malfunction or failure of such TOSHIBA products could cause loss of human life, bodily injury or damage to property.
In developing your designs, please ensure that TOSHIBA products are used within specified operating ranges as set forth in the most recent TOSHIBA products specifications. Also, please keep in mind the precautions and conditions set forth in the "Handling Guide for Semiconductor Devices," or "TOSHIBA Semiconductor Reliability Handbook" etc.
- The TOSHIBA products listed in this document are intended for usage in general electronics applications (computer, personal equipment, office equipment, measuring equipment, industrial robotics, domestic appliances, etc.). These TOSHIBA products are neither intended nor warranted for usage in equipment that requires extraordinarily high quality and/or reliability or a malfunction or failure of which may cause loss of human life or bodily injury ("Unintended Usage"). Unintended Usage include atomic energy control instruments, airplane or spaceship instruments, transportation instruments, traffic signal instruments, combustion control instruments, medical instruments, all types of safety devices, etc.. Unintended Usage of TOSHIBA products listed in this document shall be made at the customer's own risk.
- The products described in this document shall not be used or embedded to any downstream products of which manufacture, use and/or sale are prohibited under any applicable laws and regulations.
- The information contained herein is presented only as a guide for the applications of our products. No responsibility is assumed by TOSHIBA for any infringements of patents or other rights of the third parties which may result from its use. No license is granted by implication or otherwise under any patents or other rights of TOSHIBA or the third parties.
- Please contact your sales representative for product-by-product details in this document regarding RoHS compatibility. Please use these products in this document in compliance with all applicable laws and regulations that regulate the inclusion or use of controlled substances. Toshiba assumes no liability for damage or losses occurring as a result of noncompliance with applicable laws and regulations.