

SERIES: PBO-10C | **DESCRIPTION:** INTERNAL AC-DC POWER SUPPLY

FEATURES

- wide input range (85 ~ 305 Vac)
- wide operating temperature range (-40 to +85 C)
- IEC/EN/UL 62368 certified
- designed to meet 61558 & 60335 safety standards
- 1,000,000 hour MTBF
- flexible implementations to power a wide array of applications

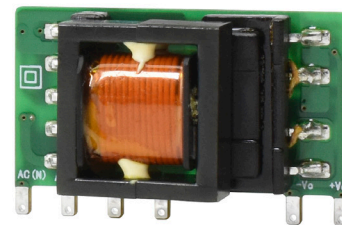

MODEL	output voltage	output current	output power	ripple and noise ¹	efficiency ²
	(Vdc)	max (A)	max (W)	typ (mVp-p)	typ (%)
PBO-10C-3	3.3	2.0	6.6	150	73.0
PBO-10C-5	5.0	2.0	10.0	150	77.0
PBO-10C-9	9.0	1.1	10.0	150	80.0
PBO-10C-12	12.0	0.83	10.0	150	82.0
PBO-10C-15	15.0	0.67	10.0	150	82.0
PBO-10C-24	24.0	0.42	10.0	150	83.0

Note: 1. At full load, nominal input, 20 MHz bandwidth oscilloscope, see Application Circuit.
 2. At 230 Vac input.

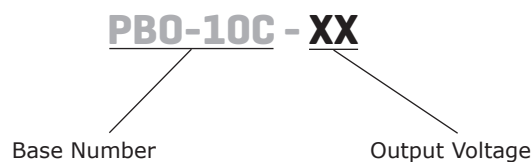
PART NUMBER KEY

INPUT

parameter	conditions/description	min	typ	max	units
voltage	ac input	85		305	Vac
	dc input	100		430	Vdc
frequency		47		63	Hz
current	at 115 Vac			0.30	A
	at 230 Vac			0.18	A
inrush current	at 115 Vac		15		A
	at 277 Vac		30		A
no load power consumption	at 230 Vac			0.10	W
	3.3 & 5 Vdc output models			0.12	W
	9, 12 & 15 Vdc output models 24 Vdc output models			0.15	W

OUTPUT

parameter	conditions/description	min	typ	max	units
capacitive load	3.3 Vdc output models			1,500	µF
	5 Vdc output models			1,500	µF
	9 Vdc output models			1,000	µF
	12 Vdc output models			680	µF
	15 Vdc output models			470	µF
	24 Vdc output models			330	µF
initial set point accuracy	3.3 Vdc output		±3		%
	other outputs		±2		%
line regulation	at rated load		±1		%
load regulation	0% ~ 100% load		±1.5		%
temperature coefficient			±0.02		%/°C

PROTECTIONS

parameter	conditions/description	min	typ	max	units
over voltage protection	output voltage clamp & hiccup				
	3.3 & 5 Vdc output models			9.0	Vdc
	9 Vdc output models			15.0	Vdc
	12 Vdc output models			16.0	Vdc
	15 Vdc output models			21.0	Vdc
	24 Vdc output models			32.0	Vdc
over current protection	auto recovery	110			%
short circuit protection	continuous, auto recovery, hiccup				

SAFETY & COMPLIANCE

parameter	conditions/description	min	typ	max	units
isolation voltage	input to output for 1 minute, leakage current <5mA	3,000			Vac
safety approvals	certified to	62368:	IEC/EN/UL		
	designed to meet	61558:	IEC, EN		
	designed to meet	60335:	IEC, EN		
safety class	class II				
EMI/EMC	CISPR32/EN55032 CLASS A (Recommended circuit 1, 4)				
	CISPR32/EN55032 CLASS B (Recommended circuit 2, 3)				
ESD	IEC/EN 61000-4-2 Contact ±6KV perf. Criteria B				
radiated immunity	IEC/EN61000-4-3 10V/m perf. Criteria A				
EFT/burst	IEC/EN61000-4-4 ±2KV (Recommended circuit 1, 2) perf. Criteria B				
	IEC/EN61000-4-4 ±4KV (Recommended circuit 3, 4) perf. Criteria B				
surge	IEC/EN61000-4-5 line to line ±1KV (Recommended circuit 1, 2) perf. Criteria B				
	IEC/EN61000-4-5 line to line±2KV (Recommended circuit 3, 4) perf. Criteria B				
conducted immunity	IEC/EN61000-4-6 10Vr.m.s perf. Criteria A				

SAFETY & COMPLIANCE (CONTINUED)

parameter	conditions/description	min	typ	max	units
voltage dips and interruptions	IEC/EN61000-4-11 0%, 70% perf. Criteria B				
MTBF	as per MIL-HDBK-217F at 25 °C	1,000,000			hours
RoHS	yes				

ENVIROMENTAL

parameter	conditions/description	min	typ	max	units
operating temperature		-40		85	°C
storage temperature		-40		105	°C
storage humidity				95	%

DERATING CURVES

TEMPERATURE DERATING CURVE

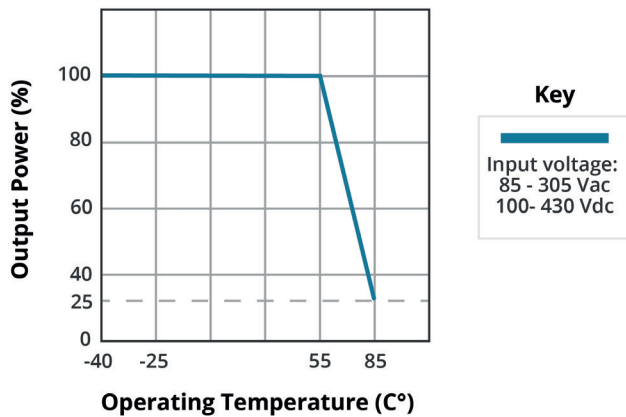

INPUT VOLTAGE DERATING CURVE (25°C)

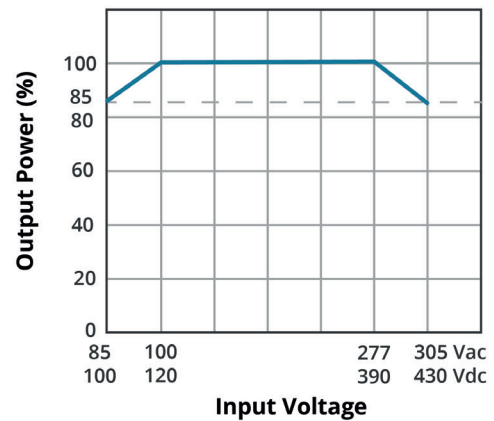

EFFICIENCY CURVES

EFFICIENCY VS INPUT VOLTAGE (FULL LOAD)

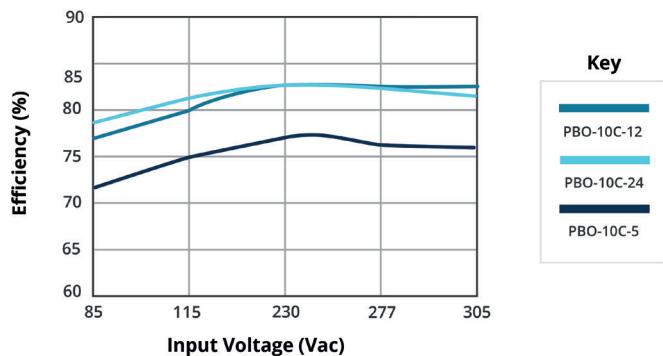

EFFICIENCY VS OUTPUT LOAD (VIN = 230 VAC)

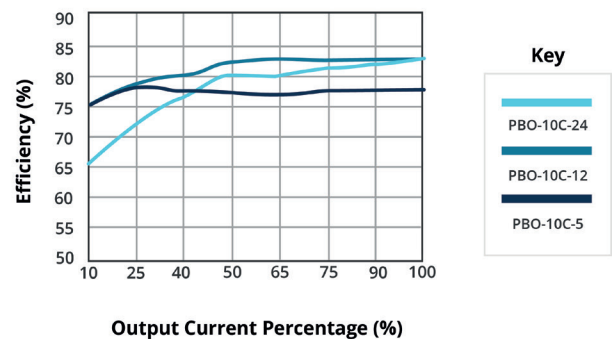

MECHANICAL

parameter	conditions/description	min	typ	max	units
dimensions	32.00 x 17.20 x 15.05 (1.259 x 0.677 x 0.592 inches)				mm
weight			8.2		g
cooling	free air convection				

MECHANICAL DRAWING

units: mm [inch]
 general tolerance: ±1.00 [±0.039]

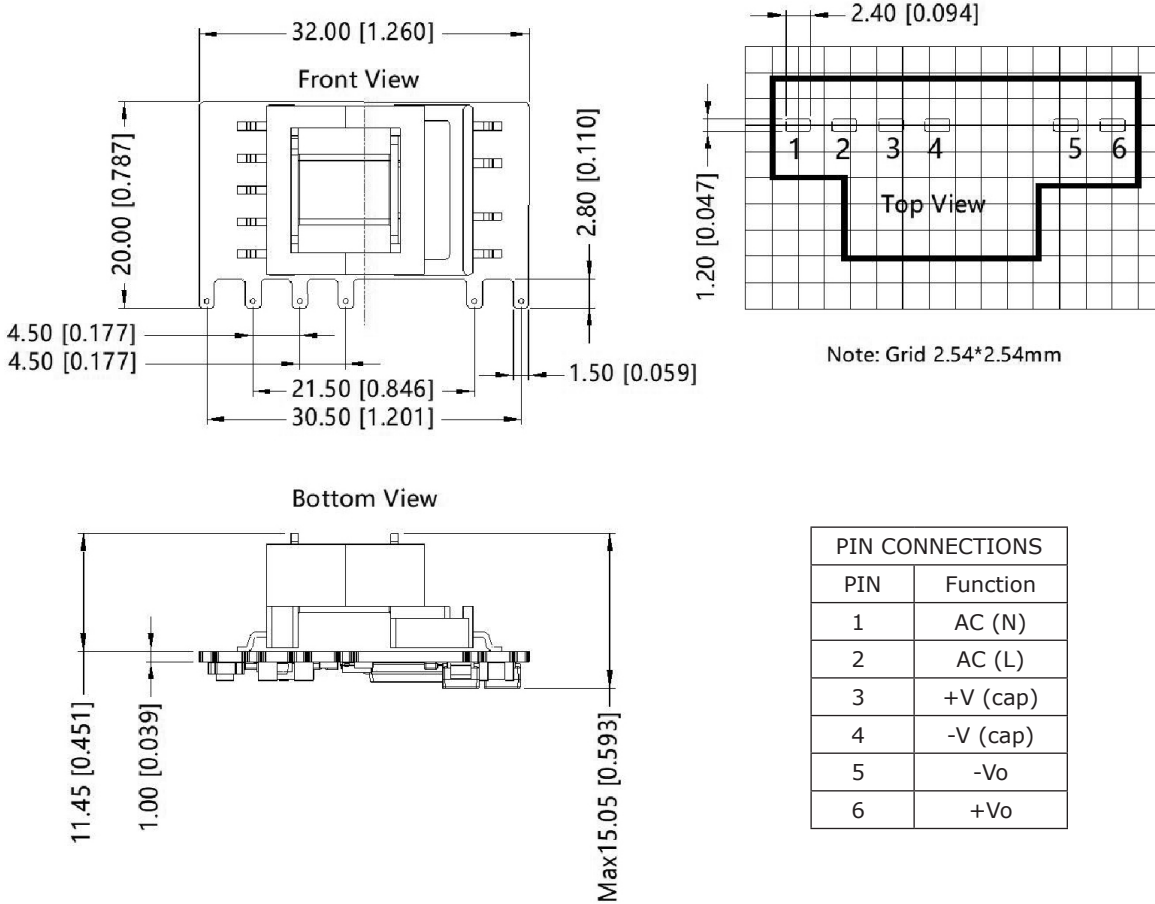

APPLICATION DESIGN REFERENCE

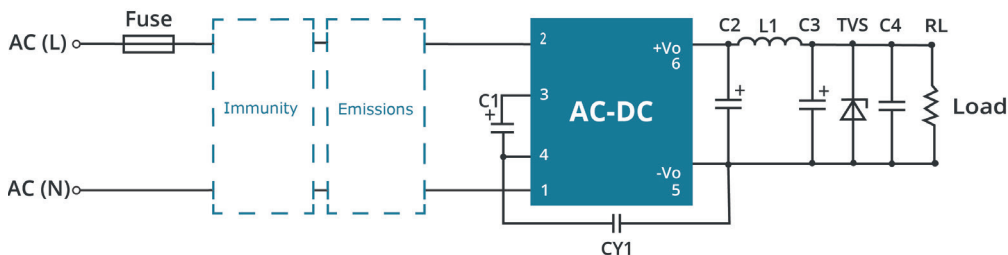

PBO-10C Series additional component selection guide (no EMC devices)

Part no.	C1 ¹ (required)	C2 (required)	L1 (required)	C3 ² (required)	C4	CY1 (required)	TVS ³
PBO-10C-3	22μF/450V	820μF/16V (solid-state capacitor)	2.2μH max 15mΩ/6.5A	150μF/35V	0.1μF/50V (ceramic capacitor)	1.0nF/400Vac	SMBJ7.0A
PBO-10C-5							SMBJ7.0A
PBO-10C-9		SMBJ12A					
PBO-10C-12		470uF/35V		220μF/35V			SMBJ20A
PBO-10C-15							SMBJ20A
PBO-10C-24		SMBJ30A					

- Note:
1. Recommended to use a capacitor with ripple current >300 mA at 100 kHz.
 2. Recommended to use a high frequency, low ESR, electrolytic capacitor with at least 20% margin on voltage rating.
 3. A suppressor diode (TVS) is recommended to protect the downstream application in case of converter failure and should be rated for a minimum of 1.2 times the converter's output voltage.

PBO-10C Series Enviromental and EMC selection guide

Recommended circuit	Application enviromental	Typical industry	Input voltage range	Enviroment temperature	Emissions	Immunity
1	Basic application	None	85~305Vac	-40°C to 85°C	Class A	Class III
2	Indoor civil environment	Smart home/Home appliances (2 Y-caps)		-25°C to 55°C	Class B	Class III
	Indoor general environment	Intelligent building/ Intelligent agriculture		-25°C to 55°C	Class B	Class IV
3	Indoor industrial	Manufacturing workshoph		-40°C to 85°C	Class A	Class IV
4	Outdoor general environment	ITS/Video monitoring/ Charging point/Com-munication/Security and protection				

Immunity design circuits reference

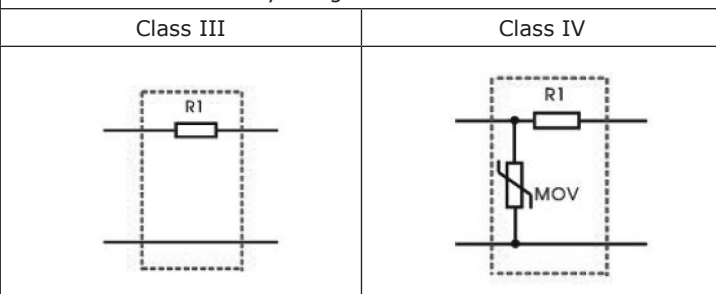

Emissions design circuits reference

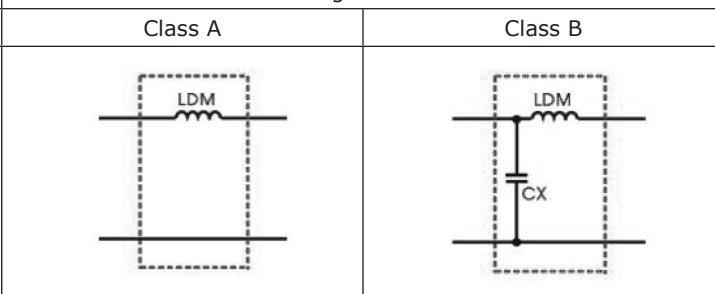

APPLICATION DESIGN REFERENCE (CONTINUED)

Circuit 1

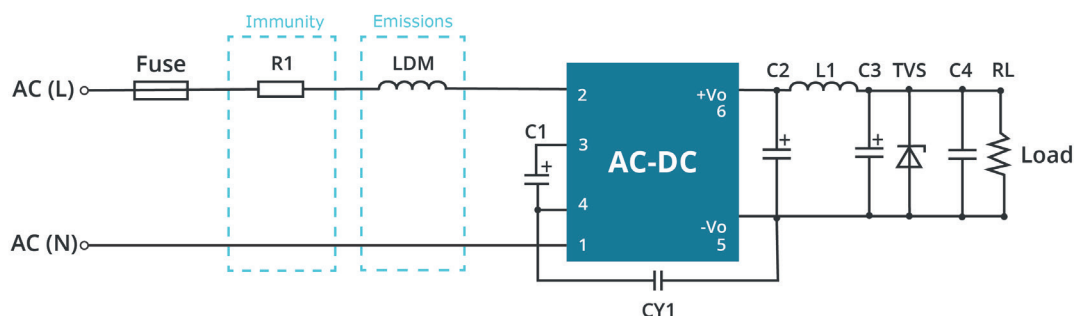

Table 1

Application enviromental	Ambient temperature range	Imunity Class	Emissions Class
Basic application	-40°C ~ 85°C	Class III	Class A

Component	Recommended value
FUSE (required)	1A/300V, slow blow
R1 (wire-wound resistor, required)	6.8Ω/3W
LDM	2.2mH/4Ω max/0.24A min

Note: R1 must be a wire-wound resistor; do not use a chip or carbon film resistor.

Circuit 2

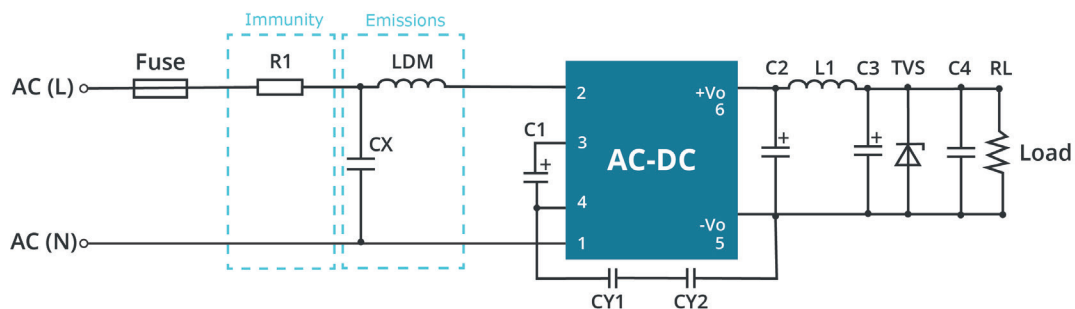

Table 2

Application enviromental	Ambient temperature range	Imunity Class	Emissions Class
Indoor civil / general	-25°C ~ 55°C	Class III	Class B

Component	Recommended value
FUSE (required)	1A/300V, slow-blow
R1 (wire-wound resistor, required)	6.8Ω/3W
CY1 (CY2)	1.0nF/400Vac
LDM	2.2mH/ 4Ω/0.24A
CX	0.1μF/310Vac

Note: 1. For Smart Home and Home Appliance applications two Y-capacitors are required in series (2.2 nF/250 Vac each) to meet 60335 household safety requirements.
 2. Many safety standards require a bleeder resistor no greater than 3.8MΩ in parallel with the X-capacitor.
 3. R1 must be a wire-wound resistor; do not use a chip or carbon film resistor.

APPLICATION DESIGN REFERENCE (CONTINUED)

Circuit 3

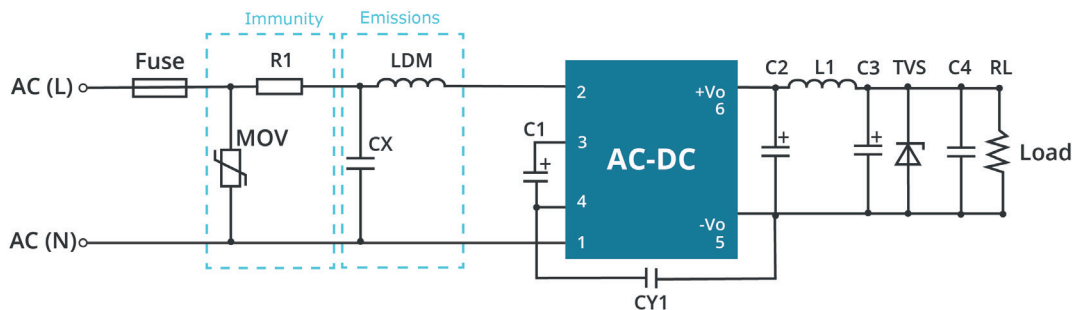

Table 3

Application environmental	Ambient temperature range	Immunity Class	Emissions Class
Indoor industrial	-25°C ~ 55°C	Class IV	Class B

Component	Recommended value
FUSE (required)	2A/300V, slow-blow
MOV	S14K350
CY1	1.0nF/400Vac
CX	0.1µF/310Vac
LDM	2.2mH/ 4Ω/0.24A
R1 (wire-wound resistor, required)	6.8Ω/3W

Note: 1. Many safety standards require a bleeder resistor no greater than 3.8MΩ in parallel with the X-capacitor.
 2. R1 must be a wire-wound resistor; do not use a chip or carbon film resistor.

Circuit 4

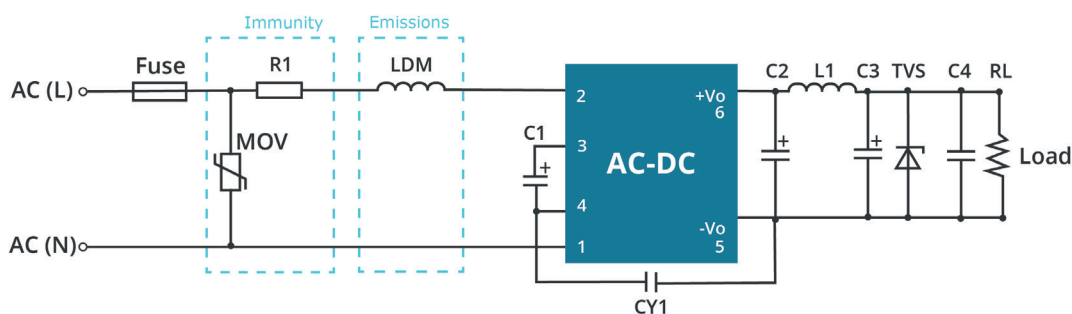

Table 4

Application environmental	Ambient temperature range	Immunity Class	Emissions Class
Outdoor general environment	-40°C ~ 85°C	Class IV	Class A

Component	Recommended value
FUSE (required)	2A/300V, slow-blow
MOV	S14K350
LDM	2.2mH/ 4Ω/0.24A
R1 (wire-wound resistor, required)	6.8Ω/3W

Note: R1 must be a wire-wound resistor; do not use a chip or carbon film resistor.

REVISION HISTORY

rev.	description	date
1.0	initial release	11/12/2020

The revision history provided is for informational purposes only and is believed to be accurate.



Headquarters
20050 SW 112th Ave.
Tualatin, OR 97062
800.275.4899

Fax 503.612.2383
cui.com
techsupport@cui.com

CUI offers a two (2) year limited warranty. Complete warranty information is listed on our website.

CUI reserves the right to make changes to the product at any time without notice. Information provided by CUI is believed to be accurate and reliable. However, no responsibility is assumed by CUI for its use, nor for any infringements of patents or other rights of third parties which may result from its use.

CUI products are not authorized or warranted for use as critical components in equipment that requires an extremely high level of reliability. A critical component is any component of a life support device or system whose failure to perform can be reasonably expected to cause the failure of the life support device or system, or to affect its safety or effectiveness.