Features

- Fully Integrated 2.4 GHz-band Transceiver
- -101 dBm Receiver Sensitivity
- Low Current Consumption (Typical Values)
 - SLEEP = 0.1 μ A
 - TRX_OFF = 1.7 mA
 - RX_ON = 16 mA
 - BUSY_TX = 17 mA (max. P_{TX})
- Power Supply Range 1.8V – 3.6V
 - Internal LDO Voltage Regulators
 - Battery Monitor
- SPI Slave Interface
- Baseband Signal Processing Compliant with IEEE 802.15.4
 - SFD Detection, Spreading/De-spreading, Framing
 - 128-byte FIFO for TRX
- Integrated Crystal Oscillator, 16 MHz
- Digital RSSI Register, 5-bit Value
- Fast Power-up Time < 1 msec
- Programmable TX Output Power from -17 dBm up to 3 dBm
- Integrated LNA
- Low External Component Count
 - Antenna
 - Reference Crystal
 - De-coupling Capacitors
- Integrated TX/RX Switch
- Integrated PLL Loop Filter
- Automatic VCO and Filter Calibration
- 32-pin Low-profile Lead-free Plastic QFN Package 5 mm x 5 mm x 0.9 mm
- Compliant to EN 300 440/328, FCC-CFR-47 Part 15
- Compliant to IEEE 802.15.4

Applications

- 802.15.4 Transceiver
- Transceiver for ZigBee System Solutions

Description

The AT86RF230 is a low-power 2.4 GHz transceiver specially designed for low cost ZigBee/IEEE802.15.4 applications. The AT86RF230 is a true SPI-to-antenna solution. All RF-critical components except the antenna, crystal and de-coupling capacitors are integrated on-chip.



**ZigBee™/IEEE
802.15.4-
Transceiver**

AT86RF230

5131A-ZIGB-06/14/06





Table of contents

1.	Abbreviations	4
2.	General Circuit Description	5
3.	Technical Parameters	6
3.1.	Absolute Maximum Ratings	6
3.2.	Recommended Operating Range	6
3.3.	Digital Pin Specifications	6
3.4.	General RF Specifications	7
3.5.	Transmitter Specifications	7
3.6.	Receiver Specifications	8
3.7.	Current Consumption Specifications	9
3.8.	SPI Timing Specifications	9
3.9.	Crystal Parameter Specifications	10
4.	Basic Operating Modes	11
4.1.	Configuration	11
4.2.	Basic Operating Mode Description	12
4.2.1.	P_ON	12
4.2.2.	SLEEP	12
4.2.3.	TRX_OFF	12
4.2.4.	PLL_ON	12
4.2.5.	RX_ON and BUSY_RX	13
4.2.6.	RX_ON_NOCLK	13
4.2.7.	BUSY_TX	13
4.3.	Basic Mode Timing	13
4.3.1.	Wake-up Procedure	13
4.3.2.	Transition from PLL_ON via BUSY_TX to RX_ON	14
4.3.3.	State Transition Timing	15
5.	Extended Operating Modes	16
5.1.	Peer-to-peer Network Support	16
5.2.	Configuration	18
5.3.	Extended Operation Mode Description	18
5.3.1.	RX_AACK_ON	18
5.3.2.	TX_ARET_ON	18
5.3.3.	RX_AACK_NOCLK	19
6.	Functional Description	20
6.1.	RSSI/Energy Detection	20
6.2.	Link Quality Indication	20
6.3.	Clear Channel Assessment	20
6.4.	Voltage Regulators	20
6.5.	Battery Monitor	21
6.6.	Crystal Oscillator	22
6.7.	PLL Frequency Synthesizer	23
6.8.	Automatic Filter Tuning	24
7.	PHY to Micro-Controller Interface	25
7.1.	SPI Protocol	25
7.2.	Register Access Mode (Short Mode)	26
7.3.	Frame Buffer Access Modes (Long Modes)	27
7.4.	Frame Receive Procedure	28
7.5.	Frame Transmit Procedure	28
7.6.	Sleep/Wake-up and Transmit Signal	29
7.7.	Interrupt Logic	30

8.	Control Registers	31
9.	Application Circuit	42
10.	Pin Configuration	44
10.1.	Pin-out Diagram.....	45
10.2.	Decoupling.....	45
10.3.	Analog Pins	45
10.4.	RF Pins.....	45
10.5.	Digital Pins.....	46
11.	Ordering Information.....	47
12.	Soldering Information.....	47
13.	Package Thermal Properties	47
14.	Package Drawing – 32QN1	48
15.	References.....	49
16.	Revisions	49



1. Abbreviations

AACK	—	Auto acknowledge
ACK	—	Acknowledge
ADC	—	Analog-to-digital converter
AGC	—	Automatic gain control
ARET	—	Auto retry
AVREG	—	Analog voltage regulator
BATMON	—	Battery monitor
BBP	—	Base-band processor
BPF	—	Complex band-pass filter
CCA	—	Clear channel assessment
CLKM	—	Clock main
CRC	—	Cyclic redundancy check
CSMA	—	Carrier sense multiple access
DCLK	—	Digital clock
DCU	—	Delay calibration unit
DVREG	—	Digital voltage regulator
ED	—	Energy detection
ESD	—	Electro static discharge
EVM	—	Error vector magnitude
FIFO	—	First in first out
FTN	—	Automatic filter tuning
GPIO	—	General purpose input output
LDO	—	Low-drop output
LNA	—	Low-noise amplifier
LO	—	Local oscillator
LQI	—	Link-quality indication
LSB	—	Least significant bit
MSB	—	Most significant bit
MSK	—	Minimum shift keying
O-QPSK	—	Offset-quadrature phase shift keying
PA	—	Power amplifier
PAN	—	Personal area network
PER	—	Packet error rate
PHY	—	Physical layer
PLL	—	Phase-locked loop
POR	—	Power-on reset
PPF	—	Poly-phase filter
PSDU	—	PHY service data unit
QFN	—	Quad flat no-lead package
RF	—	Radio frequency
RSSI	—	Received signal strength indicator
RX	—	Receiver
SFD	—	Start frame delimiter
SPI	—	Serial peripheral interface
SRAM	—	Static random access memory
TX	—	Transmitter
VCO	—	Voltage controlled oscillator
VREG	—	Voltage regulator
XOSC	—	Crystal oscillator

2. General Circuit Description

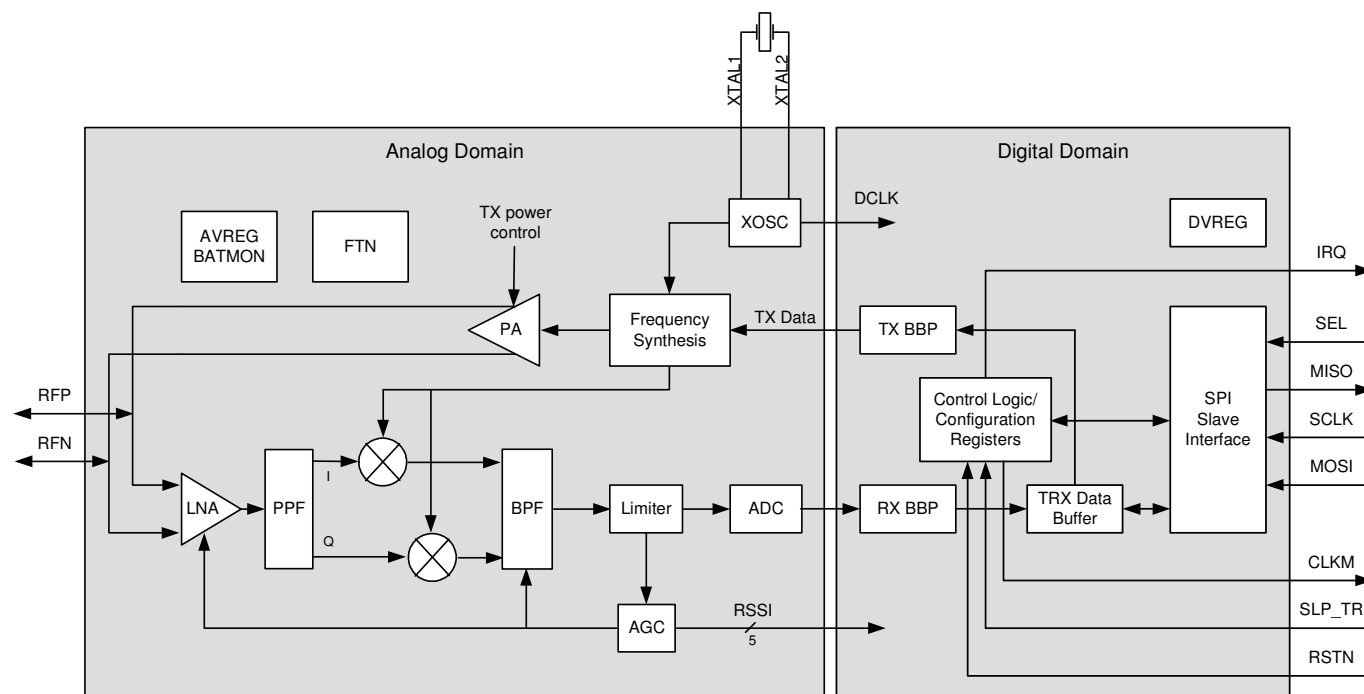

Figure 2-1. Block Diagram of AT86RF230

This single-chip RF transceiver provides a complete radio interface between the antenna and the micro-controller. It comprises the analog radio part, digital demodulation including time and frequency synchronization and data buffering. The number of external components is minimized so that only the antenna, the crystal and four decoupling capacitors are required. The bidirectional differential antenna pins are used in common for RX and TX, so no external antenna switch is needed.

The transceiver block diagram is shown in **Figure 2-1**. The receiver path is based on a low-IF topology. The channel filter consists of three single side-band active RC resonators forming a 2 MHz band-pass filter with a Butterworth characteristic centered at 2 MHz. Two 1st-order high-pass filters were added to the signal path to achieve capacitive coupling at the single side-band filter (SSBF) output to suppress DC offset and integrator feedback at the limiter amplifier. The 3-stage limiter amplifier provides sufficient gain to overcome the DC offset of the succeeding single channel ADC and generates a digital RSSI signal with 3 dB granularity. The low-IF signal is sampled at 16 MHz with 1-bit resolution and applied to the digital signal processing part.

Direct VCO modulation is used to generate the transmit signal. The modulation scheme is offset-QPSK (O-QPSK) with half-sine pulse shaping and 32-length block coding (spreading). This is equivalent to minimum shift keying (MSK) when transforming the spreading code sequences appropriately. The modulation signal is applied to both the VCO and the fractional-N PLL to ensure the coherent phase modulation required for demodulation as an O-QPSK signal. The frequency-modulated LO signal is fed to the power amplifier.

Two on-chip low-dropout voltage regulators provide the analog and digital 1.8V supply. The SPI interface and the control registers will retain their settings in SLEEP mode when the regulators are turned off. The RX and TX signal processing paths are highly integrated and optimized for low power consumption.



3. Technical Parameters

3.1. Absolute Maximum Ratings

Note: Stresses beyond those listed under “Absolute Maximum Ratings” may cause permanent damage to the device. This is a stress rating only and functional operation of the device at these or any other conditions beyond those indicated in the operational sections of this specifications is not implied. Exposure to absolute maximum rating conditions for extended periods may affect device reliability.

No	Parameter	Symbol	Min	Typ	Max	Unit	Conditions/Notes
3.1.1	Storage temperature	T_{stor}	-50		150	°C	
3.1.2	Lead temperature	T_{lead}			260	°C	T = 10s (soldering profile compliant with IPC/JEDEC J-STD-020B)
3.1.3	ESD-protection	V_{ESD}	2 200 500			kV V V	Compl. to [2], passed 4 kV Compl. to [3], Compl. to [4], passed 750V
3.1.4	Input RF level	P_{RF}			+10	dBm	
3.1.5	Voltage on all pins (except pins 13, 14, 29)		-0.3		$V_{dd}+0.3$ ≤ 3.6	V	
3.1.6	Voltage on pins 13, 14, 29		-0.3		2	V	

Table 3-1. Absolute Maximum Ratings

3.2. Recommended Operating Range

No	Parameter	Symbol	Min	Typ	Max	Unit	Conditions/Notes
3.2.1	Operating temperature range	T_{op}	-40		+85	°C	
3.2.2	Supply voltage	V_{dd}	1.8		3.6	V	

Table 3-2. Operating Range

3.3. Digital Pin Specifications

Test Conditions (unless otherwise stated): $T_{amb} = 25^{\circ}\text{C}$

No	Parameter	Symbol	Min	Typ	Max	Unit	Conditions/Notes
3.3.1	High level input voltage	V_{IH}	$V_{dd} - 0.4$			V	
3.3.2	Low level input voltage	V_{IL}			0.4	V	
3.3.3	High level output voltage	V_{OH}	$V_{dd} - 0.4$			V	For all output current loads defined in register TRX_CTR_0
3.3.4	Low level output voltage	V_{OL}			0.4	V	For all output current loads defined in register TRX_CTR_0

No	Parameter	Symbol	Min	Typ	Max	Unit	Conditions/Notes
3.3.5	Controller clock frequency (CLKM)	f _{CLKM}		0		MHz	Programmable in register TRX_CTRL_0
				1		MHz	
				2		MHz	
				4		MHz	
				8		MHz	
				16		MHz	

Table 3-3. Digital Pin Specifications

The capacitive load should not be larger than 50 pF for all I/Os when using the default driver strength settings. Generally, large load capacitances will increase the overall current consumption.

3.4. General RF Specifications

Test Conditions (unless otherwise stated): V_{dd} = 3V, f = 2.45 GHz, T_{amb} = 25 °C, Measurement setup see **Figure 9-1**

No	Parameter	Symbol	Min	Typ	Max	Unit	Conditions/Notes
3.4.1	Frequency range	f	2405		2480	MHz	
3.4.2	Bit rate	f _{bit}		250		kbit/s	As specified in [1]
3.4.3	Chip rate	f _{chip}		2000		kchip/s	As specified in [1]
3.4.4	Reference oscillator frequency	f _{clk}		16		MHz	
3.4.5	Reference oscillator settling time			0.5	1	ms	Leaving SLEEP state to clock available at pin CLKM
3.4.6	Reference frequency accuracy for correct functionality		-60		+60	ppm	±40 ppm is required by [1]
3.4.7	20 dB bandwidth	B _{20dB}		2.8		MHz	

Table 3-4: General RF Parameters

3.5. Transmitter Specifications

Test Conditions (unless otherwise stated): V_{dd} = 3V, f = 2.45 GHz, T_{amb} = 25 °C, Measurement setup see **Figure 9-1**

No	Parameter	Symbol	Min	Typ	Max	Unit	Conditions/Notes
3.5.1	Nominal output power	P _{TX}	0	3	6	dBm	Max. value
3.5.2	Output power range			20		dB	16 steps (register PHY_TX_PWR)
3.5.3	Output power accuracy				±3	dB	
3.5.4	TX Return loss			10		dB	100Ω differential impedance, P _{TX} = 3 dBm
3.5.5	EVM			8		%rms	Channel number = 20
3.5.6	Harmonics						
	2nd harmonic			-38		dBm	
	3rd harmonic			-45		dBm	



No	Parameter	Symbol	Min	Typ	Max	Unit	Conditions/Notes
3.5.7	Spurious emissions 30 – ≤1000 MHz >1 – 12.75 GHz 1.8 – 1.9 GHz 5.15 – 5.3 GHz				-36 -30 -47 -47	dBm dBm dBm dBm	Complies with EN 300 440, FCC-CFR-47 part 15, ARIB STD-66, RSS-210

Table 3-5. TX Parameters

3.6. Receiver Specifications

Test Conditions (unless otherwise stated): $V_{dd} = 3V$, $f = 2.45\text{ GHz}$, $T_{amb} = 25^{\circ}\text{C}$, Measurement setup see **Figure 9-1**

No	Parameter	Symbol	Min	Typ	Max	Unit	Conditions/Notes
3.6.1	Receiver sensitivity			-101		dBm	AWGN channel, $PER \leq 1\%$, PSDU length of 20 octets
3.6.2	Return loss			10		dB	100Ω differential impedance
3.6.3	Noise figure	NF		6		dB	
3.6.4	Maximum RX input level			10		dBm	$PER \leq 1\%$, PSDU length of 20 octets
3.6.5	Adjacent channel rejection -5 MHz			34		dBm	$PER \leq 1\%$, PSDU length of 20 octets, $P_{RF} = -82\text{ dBm}$
3.6.6	Adjacent channel rejection +5 MHz			36		dBm	$PER \leq 1\%$, PSDU length of 20 octets, $P_{RF} = -82\text{ dBm}$
3.6.7	Alternate adjacent channel rejection -10 MHz			52		dBm	$PER \leq 1\%$, PSDU length of 20 octets, $P_{RF} = -82\text{ dBm}$
3.6.8	Alternate adjacent channel rejection +10 MHz			53		dBm	$PER \leq 1\%$, PSDU length of 20 octets, $P_{RF} = -82\text{ dBm}$
3.6.9	Spurious emissions LO leakage 30 – 1000 MHz 1 – 12.75 GHz			-75	-57 -47	dBm dBm dBm	
3.6.10	TX/RX carrier frequency offset		-300		300	kHz	Sensitivity loss < 2 dB
3.6.11	3 rd -order intercept point	IIP3		-9		dB	At maximum gain Offset freq. interf. 1 = 5 MHz Offset freq. interf. 2 = 10 MHz
3.6.12	2 nd -order intercept point	IIP2		24		dB	At maximum gain Offset freq. interf. 1 = 60 MHz Offset freq. interf. 2 = 62 MHz
3.6.13	RSSI accuracy absolute		-5		5	dB	Tolerance within gain step
3.6.14	RSSI dynamic range			84		dB	
3.6.15	RSSI resolution			3		dB	
3.6.16	Minimum RSSI value			0			$P_{RF} < -91\text{ dBm}$
3.6.17	Maximum RSSI value			28			$P_{RF} > -10\text{ dBm}$

Table 3-6. RX Parameters

3.7. Current Consumption Specifications

Test Conditions (unless otherwise stated): $V_{dd} = 3V$, $T_{amb} = 25^{\circ}C$, CLKM = OFF, Measurement setup see Figure 9-1

No	Parameter	Symbol	Min	Typ	Max	Unit	Conditions/Notes
3.7.1	Supply current transmit mode	I _{BUSY_TX}		17 15 13 10		mA mA mA mA	P _{TX} = 3 dBm P _{TX} = 1 dBm P _{TX} = -3 dBm P _{TX} = -17 dBm (the current consumption will be reduced by approx. 2 mA at $V_{dd} = 1.8V$ for each output power level)
3.7.2	Supply current receive mode	I _{RX_ON}		16		mA	State: RX_ON
3.7.3	Supply current TRX_OFF mode	I _{TRX_OFF}		1.7		mA	State: TRX_OFF
3.7.4	Supply current SLEEP mode	I _{SLEEP}		0.1		μA	State: SLEEP

Table 3-7. Current Consumption

3.8. SPI Timing Specifications

Test Conditions (unless otherwise stated): $V_{dd} = 3V$, $T_{amb} = 25^{\circ}C$

No	Parameter	Symbol	Min	Typ	Max	Unit	Conditions/Notes
3.8.1	SCLK frequency (synchronous)				8	MHz	
3.8.2	SCLK frequency (asynchronous)				7.5	MHz	
3.8.3	\overline{SEL} low to MISO active	t ₁			180	ns	
3.8.4	SCLK to MISO out	t ₂	48			ns	data hold time
3.8.5	MOSI setup time	t ₃	10			ns	
3.8.6	MOSI hold time	t ₄	10			ns	
3.8.7	LSB last byte to MSB next byte	t ₅			250	ns	
3.8.8	\overline{SEL} high to MISO tristate	t ₆			10	ns	
3.8.9	SLP_TR pulse width	t ₇	65			ns	

Table 3-8. SPI Timing Parameters (see Figure 7-2)



3.9. Crystal Parameter Specifications

No	Parameter	Symbol	Min	Typ	Max	Unit	Conditions/Notes
3.9.1	Crystal frequency	f_0		16		MHz	
3.9.2	Load capacitance	C_L	8		14	pF	
3.9.3	Static capacitance	C_0			7	pF	
3.9.4	Series resistance	R_1			100	Ω	

Table 3-9. Crystal Parameter Specifications

4. Basic Operating Modes

This section summarizes all features that are needed to provide the basic functionality of a transceiver system, such as receiving and transmitting frames, and powering down. These basic operating modes are sufficient for ZigBee applications and are shown in **Figure 4-1**.

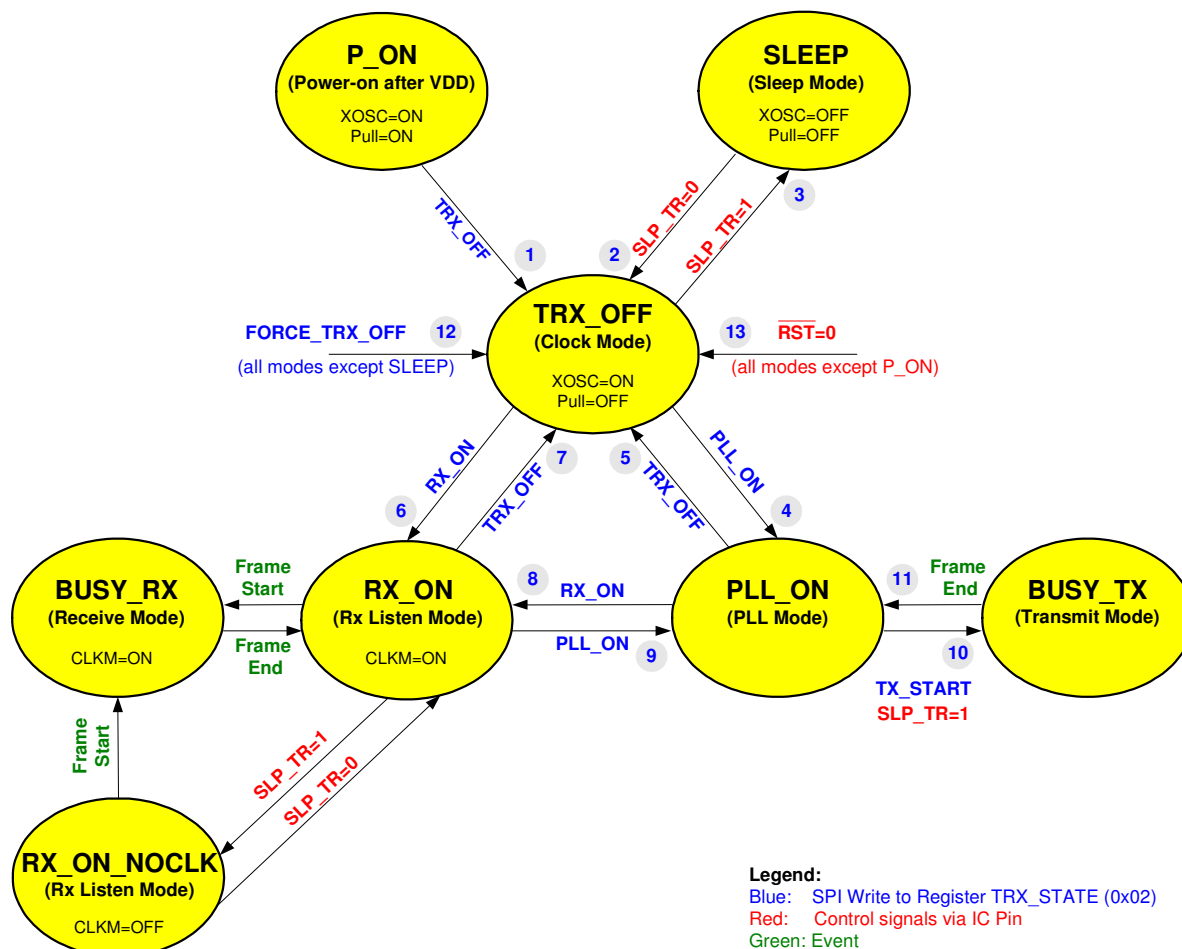

Figure 4-1. Basic Operating Modes State Diagram

4.1. Configuration

The operating modes are controlled by two signal pins and the SPI access to register 0x02 (TRX_STATE). The successful state change can be confirmed by reading the transceiver state from register 0x01 (TRX_STATUS).

The pin SLP_TR is used to enter SLEEP mode where current consumption is minimal (leakage current only) and to wake-up the transceiver.

The pin $\overline{\text{RST}}$ provides a reset of all registers and forces the transceiver into TRX_OFF mode, if the IC is not in the P_ON mode.



The state change commands `FORCE_TRX_OFF` and `TRX_OFF` both lead to a transition into `TRX_OFF` state. If the transceiver is in the `BUSY_RX` or `BUSY_TX` state, the command `FORCE_TRX_OFF` interrupts the active receiving or transmitting process, and forces an immediate transition. On the other hand, a `TRX_OFF` command is stored until a frame currently being received or transmitted is finished. After the end of the frame, the transition to `TRX_OFF` is performed.

4.2. Basic Operating Mode Description

4.2.1. P_ON

When the external supply voltage (VDD) is first supplied to the transceiver IC, the system is in the `P_ON` (Power-on) mode. In this mode, the crystal oscillator is activated and the master clock for the controller is provided at the `CLKM` pin after a delay of 128 μ s to ensure a steady state of the crystal oscillator.

All digital inputs have pull-up or pull-down resistors (see Table 10-3). This is necessary to support controllers where GPIO signals are undefined after reset. The input pull-up and pull-down resistors are disabled when the transceiver leaves the `P_ON` state.

A valid SPI write access to the register `TRX_STATE` with the values `TRX_OFF` or `FORCE_TRX_OFF` is necessary to leave the `P_ON` state.

Prior to leaving `P_ON`, the controller must set the pins to the default operating values: `SLP_TR` = 0 and $\overline{\text{RST}} = 1$.

An on-chip power-on-reset sets the all register to its default values. A dedicated reset signal from the controller at the pin `RST` is not necessary, but recommended for HW/SW synchronization reasons.

4.2.2. SLEEP

In `SLEEP` mode, the entire transceiver IC is disabled. No circuitry is running. The current consumption in this mode is leakage current only. This mode can only be entered from state `TRX_OFF`, when the pin `SLP_TR` is set to "1". There is no way to switch the transceiver to `SLEEP` mode via SPI register access.

Leaving this state is possible in two ways:

Setting the `SLP_TR` pin to "0" returns the transceiver to the `TRX_OFF` mode without resetting any registers. Using $\overline{\text{RST}} = 0$ resets the SPI and configuration registers to their default values and forces the IC into the `TRX_OFF` mode.

4.2.3. TRX_OFF

The `TRX_OFF` mode provides the master clock for the controller in synchronous operation mode, allowing the software to run without the need for the radio to be powered on. The pins `SLP_TR` and $\overline{\text{RST}}$ are enabled for mode control.

In this mode, the SPI interface and crystal oscillator are active. The voltage regulator is enabled and provides 1.8V to the digital core for have access to the frame data buffers.

The transition from `P_ON` to `TRX_OFF` mode is described in section 4.2.1.

4.2.4. PLL_ON

Entering the `PLL_ON` mode from `TRX_OFF` will first enable the analog voltage regulator. After the voltage regulator has settled, the PLL frequency synthesizer is enabled. When the PLL has settled at the receive frequency, a successful PLL lock is indicated by an interrupt request at the `IRQ` pin.

During `PLL_ON` mode, the command `RX_ON` via register 0x02 (`TRX_STATE`) sets the transceiver to `RX_ON` mode, even if the PLL is not yet settled.

4.2.5. RX_ON and BUSY_RX

The RX_ON mode enables the analog and digital receiver blocks and the PLL frequency synthesizer. The transition from TRX_OFF mode to RX_ON mode is started by setting the TRX_STATE to RX_ON via a SPI write access to register 0x02 (TRX_STATE).

The receive mode is internally divided into RX_ON mode and BUSY_RX mode. There is no difference between the modes with respect to the analog radio part. During RX_ON mode, only the preamble detection of the digital signal processing is running. When a preamble is detected, the digital receiver is turned on, switching to the BUSY_RX mode.

SLP_TR = 1 is only evaluated in RX_ON mode. When receiving a frame in BUSY_RX mode, the SLP_TR pin has no effect.

4.2.6. RX_ON_NOCLK

If the radio is listening for an incoming frame and the controller is not running an application, the controller can be powered down to decrease the total system power consumption. This special power-down scenario for controllers running in synchronous mode is supported by the AT86RF230 using the state RX_ON_NOCLK.

This state can only be entered by setting SLP_TR = 1 while the IC is in the RX_ON mode. The CLKM pin will then be disabled 35 clock cycles after the rising edge at the SLP_TR pin. This will enable the controller to complete its power-down sequence. The reception of a frame is signaled to the controller by a RX_START IRQ (see **Figure 7-13**). The clock CLKM is turned on once again and the transceiver enters the BUSY_RX state.

The end of the transaction is signaled to the controller by an TRX_END interrupt. After the transaction has been completed, the transceiver will enter the RX_ON state. The transceiver will only re-enter the RX_ON_NOCLK state when the SLP_TR has been reset to "0", and afterwards set to "1" again.

If the transceiver is in the RX_ON_NOCLK state, and the SLP_TR pin is reset to "0", it will enter the RX_ON state, and it will again start to supply the micro-controller with the clock signal.

4.2.7. BUSY_TX

Transmitting can only be started from PLL_ON mode. There are two ways to start transmitting: using pin SLP_TR = 1 or SPI command TX_START in register 0x02 (TRX_STATE). Either of these will cause the IC to enter BUSY_TX mode.

During the transition to BUSY_TX mode, the PLL frequency shifts 1.5 MHz to enable the different LO frequencies needed between receive and transmit modes. Transmission of the first data chip of the preamble is delayed by 16 μ s to allow PLL settling and PA ramping.

When the end of the frame has been transmitted, the IC will automatically turn off the power amplifier and transition from the BUSY_TX mode to the PLL_ON mode. The PLL settles to the receiver LO frequency (-1.5 MHz frequency step).

If the frame transmission was initiated by setting the pin SLP_TR to "1", a new transmission will only be started when the pin SLP_TR has been reset to "0" and afterwards to set to "1" again.

4.3. Basic Mode Timing

The following paragraphs depict the method of switching from one mode to another.

4.3.1. Wake-up Procedure

The wake-up procedure from SLEEP mode is shown in **Figure 4-2**.

Deasserting the pin SLP_TR enables the crystal oscillator. After approximately 0.3 - 0.5 ms, the internal clock signal is available. After 128 μ s the clock signal is delivered at the CLKM pin providing the master clock to the

micro-controller. An additional 256 μs timer ensures that frequency stability is sufficient to drive filter tuning (FTN) and the PLL. After band-gap voltage and digital voltage regulator settling, the transceiver enters the TRX_OFF state and waits for further commands.

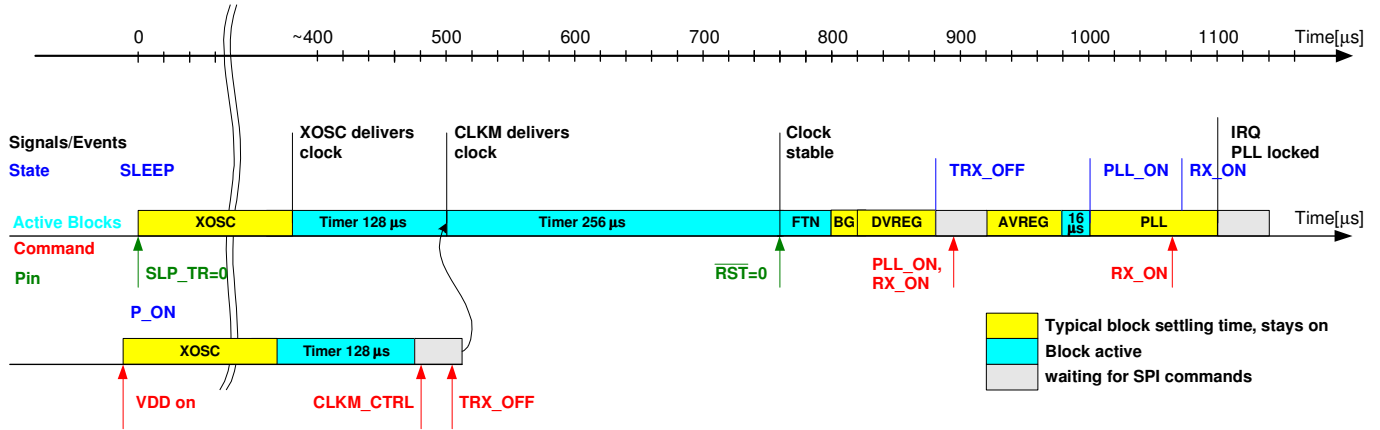

Figure 4-2. Wake-up Procedure from SLEEP Mode and P_ON Mode to RX_ON Mode (PLL locked)

Forcing PLL_ON mode or RX_ON mode initiates a ramp-up sequence of the analog voltage regulator followed by a 16 μs timer. This timer makes sure that the analog 1.8V supply is stabilized before enabling PLL circuitry. RX_ON mode can be forced any time during PLL_ON mode regardless of the PLL lock signal.

When the wake-up sequence is started from P_ON mode (VDD first applied to the IC) the state machine will stop after the 128 μs timer to wait for a valid TRX_OFF command from the micro-controller. The default CLKM frequency value in P_ON mode is 1 MHz. At this rate, an SPI access requires approximately 38 μs . The SPI programming in synchronous mode can be speeded up by setting the frequency of the clock output at pin CLKM in register 0x03 (TRX_CTRL_0) to the maximum value allowed.

If a chip reset with $\overline{\text{RST}} = 0$ is generated, the sequence starts with filter tuning (FTN) as indicated in Figure 4-2.

4.3.2. Transition from PLL_ON via BUSY_TX to RX_ON

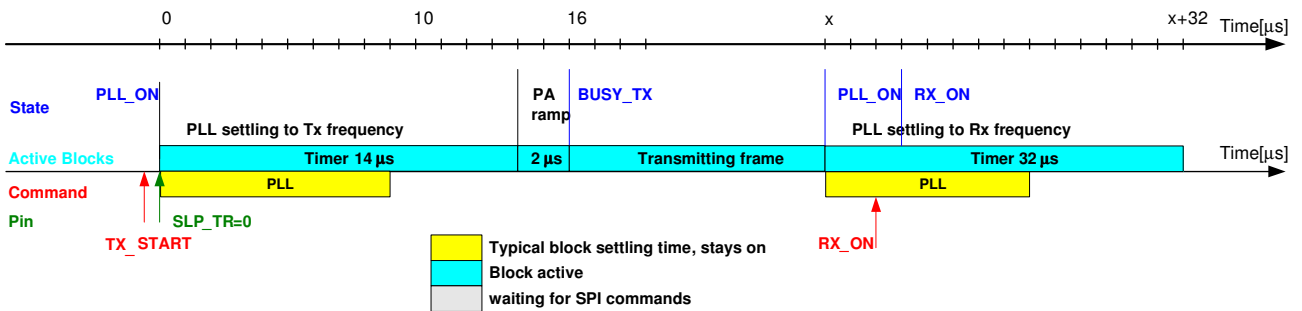

Figure 4-3. Switching from TX to RX

The time scale in **Figure 4-3** is relative to TX frame start.

4.3.3. State Transition Timing

The transition numbers correspond to **Figure 4-1** and do not include SPI access time if not otherwise stated. See measurement setup in **Figure 9-1**.

No	Transition	Time [μs] (typical)	Comments
1	P_ON → TRX_OFF	1880	Internal power-on reset, including 1000 μs for controller access, depends on external block capacitor at VDEC1 (1 μF nom) and crystal oscillator setup (C _L = 10 pf)
2	SLEEP → TRX_OFF	880	Depends on external block capacitor at VDEC1 (1 μF nom) and crystal oscillator setup (C _L = 10 pf)
3	TRX_OFF → SLEEP	35	35 cycles of 1 MHz clock assumed.
4	TRX_OFF → PLL_ON	180	Depends on external block capacitor at VDEC2 (1 μF nom).
5	PLL_ON → TRX_OFF	1	
6	TRX_OFF → RX_ON	180	
7	RX_ON → TRX_OFF	1	
8	PLL_ON → RX_ON	1	
9	RX_ON → PLL_ON	1	
10	PLL_ON → BUSY_TX	16	Asserting SLP_TR pin
11	BUSY_TX → PLL_ON	32	
12	All modes → TRX_OFF	1	Using TRX_CMD FORCE_TRX_OFF (see register 0x02), not valid for SLEEP mode
13	$\overline{\text{RST}}=0$ → TRX_OFF	120	Depends on external block capacitor at VDEC1 (1 μF nom), not valid for P_ON mode

Table 4-1. State Transition Timing

The state transition timing is calculated based on the timing of the single blocks shown in **Figure 4-2**. The worst case values include maximum operating temperature, minimum supply voltage, and device parameter variations.

Block	Time [μs] (typical)	Time [μs] (worst case)	Comments
XOSC	500	1000	Depends on crystal Q factor and load capacitor.
DVREG	60	1000	Depends on external block capacitor at VDEC1 (CB3 = 1 μF nom., 10 μF worst case).
AVREG	60	1000	Depends on external block capacitor at VDEC2 (CB1 = 1 μF nom., 10 μF worst case).
PLL, initial	100	150	
PLL, RX → TX	16		
PLL, TX → RX	32		

Table 4-2. Block Timing



5. Extended Operating Modes

The AT86RF230 transceiver implements address filtering, automatic acknowledgement frame generation and automatic frame retransmission for peer-to-peer networks in compliance with the IEEE 802.15.4 standard. Automatic modes help to achieve low power consumption and low peak current: TX-ARET (transmit/auto-retry) and RX-AACK (receive/auto-acknowledge).

A TX-ARET transaction consists of:

- CSMA/CA
- Frame transmission (if the channel is available) and automatic CRC generation
- Reception of ACK frame (if required by frame type and ACK request)
- Retry of CSMA/CA if the channel is busy or an ACK is expected but not received
- Interrupt signaling at the end of the transaction, with exit code (success, channel busy, no ACK)

A RX-AACK frame reception consists of:

- Frame reception and automatic CRC check
- Address filtering
- Interrupt signaling that the frame was received (if it passes address filtering)
- Automatic ACK frame transmission (if the received frame passed the address filter and if an ACK is required by the frame type and ACK request)

A state diagram including these extended operating modes is shown in **Figure 5-1**.

5.1. Peer-to-peer Network Support

The automatic modes of the AT86RF230 are designed for peer-to-peer networks and non-slotted operation, as defined in the IEEE 802.15.4 standard.

Note that automatic CRC generation can only be applied in conjunction with the TX-ARET mode, and automatic CRC check will only be applied in RX-AACK mode.

In RX-AACK mode, an ACK frame will always be sent with the data-pending bit set to zero. In TX-ARET mode, an ACK is considered to be valid if the CRC is valid, and if the sequence number of the ACK corresponds to the previously transmitted frame. The value of the “data-pending” bit is ignored.

Important Note: ACK frames will not be automatically generated for frames with either the broadcast PAN ID (0xFFFF) or a broadcast address.

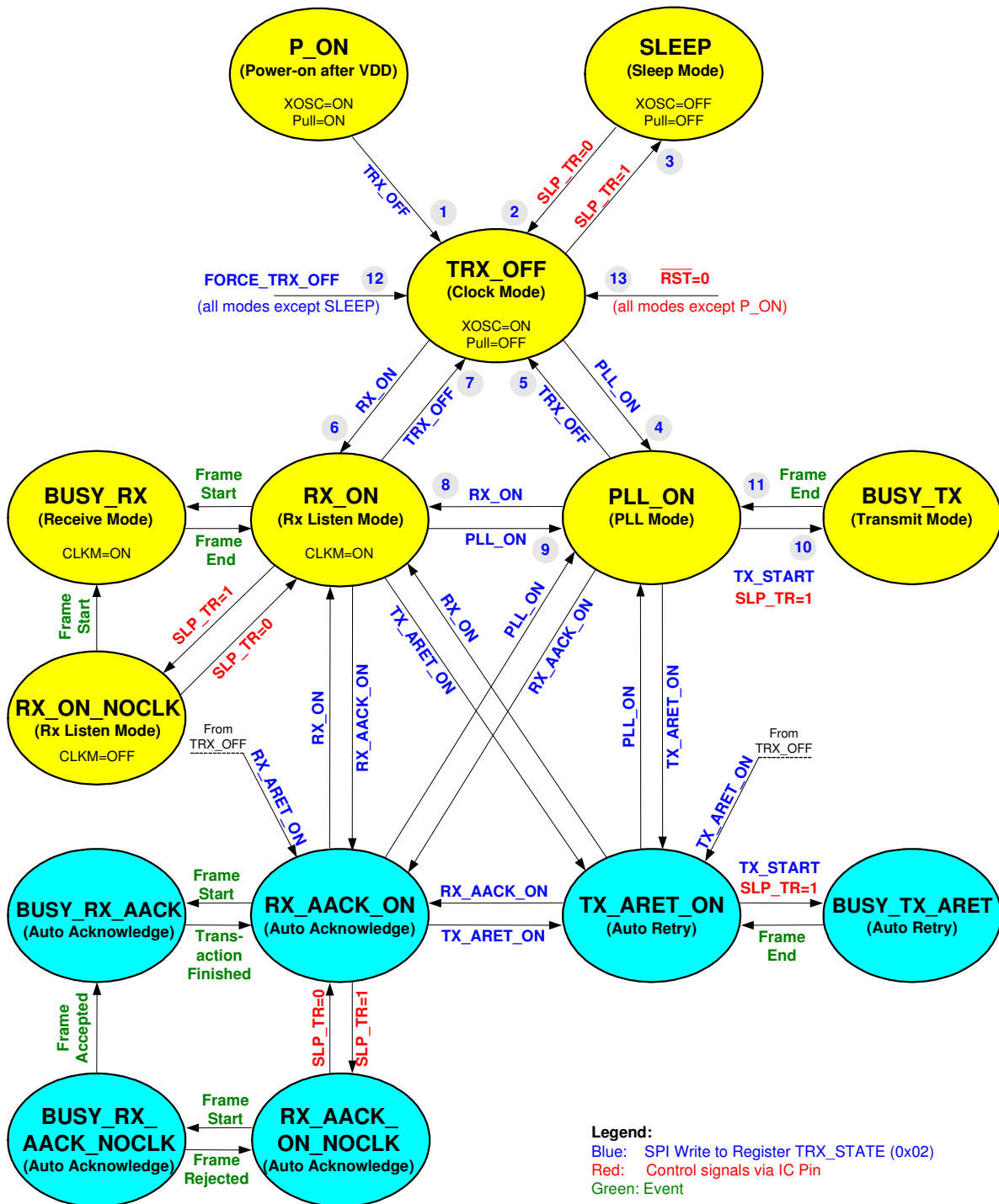

Figure 5-1. Extended Operating Mode State Diagram



5.2. Configuration

The initialization of the AT86RF230 prior to using RX-AACK or the TX-ARET mode is similar to initializing the IC prior to switching to regular RX or TX modes.

RX_AACK_ON mode is enabled after the register bits TRX_CMD in register 0x02 (TRX_STATE) is written using RX_AACK_ON. The IC is in the RX_AACK_ON mode when the register 0x01 (TRX_STATUS) changes to RX_AACK_ON or BUSY_RX_AACK. For correct RX_AACK_ON operation, the register bit TX_AUTO_CRC_ON (register 0x05) must be set to “1”.

Similarly, TX_ARET_ON mode is enabled after the register bits TRX_CMD is written with TX_ARET_ON. The IC is in the TX_ARET_ON mode after TRX_STATUS changes to TX_ARET_ON or to BUSY_TX_ARET. For correct TX-ARET operation, the register bit TX_AUTO_CRC_ON (register 0x05) must be set to “1”.

The CSMA/CA algorithm can be configured using the 0x2D (CSMA_SEED_0) and the 0x2E (CSMA_SEED_1) registers. The MIN_BE register bits sets the minimum back-off exponent (refer to the IEEE 802.15.4 standard), and the CSMA_SEED_* register bits define a random seed for the back-off-time random-number generator in the AT86RF230. The register bits MAX_CSMA_RETRIES (register 0x2C) configures how often the transceiver will retry the CSMA/CA algorithm after a busy channel is initially detected.

Both automatic modes can be exited by writing a new mode command to the register bits TRX_CMD in register 0x02 (TRX_STATE). Polling the 0x01 (TRX_STATUS) register for the new state confirms that the transceiver has left the automatic mode.

5.3. Extended Operation Mode Description

5.3.1. RX_AACK_ON

In the RX_AACK_ON mode, the transceiver listens for incoming frames.

After detecting a frame start, the transceiver will parse the frame contents for frame type and destination address. The filtering procedure described in IEEE 802.15.4 will be applied to the frame. Any frames rejected by address filtering will be discarded. A frame will also be discarded if the CRC is found to be invalid.

Otherwise, the TRX_END interrupt will be raised after the reception of the frame is completed. The controller can then upload the frame.

The transceiver also detects if an ACK frame needs to be sent. If this is true, the transceiver will automatically send an ACK frame 12 symbol periods after the end of the received frame. Only ACKs with a cleared data-pending bit will be transmitted.

No ACK will be sent if no ACK is required.

5.3.2. TX_ARET_ON

In TX_ARET_ON mode, the transceiver executes the CSMA/CA algorithm and transmits a frame downloaded by the controller. If necessary, it will check for an ACK reply, and signal the result of the transaction by raising a TRX_END interrupt. After the interrupt, the controller may read the value of the register bits TRAC_STATUS (register 0x02) to determine whether or not the transaction was successful.

The CSMA/CA transmission transaction is started by pulsing the SLP_TR pin high for at least one microsecond. The frame data must have already been downloaded. Alternatively, the controller may download the frame data while the transceiver is transmitting the preamble. In this case, it is the responsibility of the controller to ensure that the data arrives sufficiently early.

The transceiver executes the un-slotted CSMA/CA algorithm as defined by the IEEE 802.15.4 standard. If a clear channel is detected during CSMA/CA execution, the transceiver will proceed to transmit the frame. If the CSMA/CA did not detect a clear channel, the channel access will be retried as often as set by the register bits MAX_CSMA_RETRIES in register 0x2C (XAH_CTRL). In case that CSMA/CA does not detect a clear channel

even after the maximum number of retries, it will abort the transaction, raise the TRX_END interrupt, and set the value of the TRAC_STATUS register bits to CHANNEL_ACCESS_FAILURE.

Upon the detection of a clear channel, the transceiver starts the frame transmission. It parses the frame as it is transmitted to check if an ACK reply will be expected. If no ACK is expected, the transceiver will raise an interrupt after the frame transmission completes. The value of register bits TRAC_STATUS (register 0x02) is set to SUCCESS.

On the other hand, if the transmitted frame requires an ACK, the transceiver switches into receive mode to wait for a valid ACK reply. If no valid ACK is received, the transceiver will retry the entire transaction, including CSMA/CA execution, until the frame has been acknowledged or the maximum number of retransmissions (as set by the register bits MAX_FRAME_RETRIES in register 0x2C) has been reached. In this case, the TRX_END interrupt is raised and the value of TRAC_STATUS is set to NO_ACK.

If a valid ACK is found, the TRX_END interrupt will be raised. In this case, TRAC_STATUS is set to SUCCESS.

5.3.3. RX_AACK_NOCLK

If the radio is listening for an incoming frame and the controller is not running an application, the controller can be powered down to decrease the total system power consumption. This special power down scenario (similar to RX_ON_NOCLK) for controllers running in synchronous mode is supported by the AT86RF230 using the state RX_AACK_NOCLK.

The state can only be entered by setting SLP_TR = 1 while the IC is in the RX_AACK_ON mode. The CLKM pin will be disabled 35 clock cycles after the rising edge at the SLP_TR pin. This will enable the controller to complete its power down sequence.

In RX_AACK_NOCLK mode, the transceiver listens for IEEE 802.15.4 frames. Should the AT86RF230 detect an Start-of-Frame-Delimiter, it will enter the BUSY_RX_AACK_NOCLK state, and it will start to receive the frame. If the frame passes the address filter, the AT86RF230 enters the BUSY_RX_AACK state, and the clock supplied to the micro-controller is turned back on. The controller may now process the incoming frame.

If the received frame has a valid CRC, and if it requires an acknowledgement, the transceiver will automatically generate and transmit an ACK frame.

The end of the transaction is signaled to the controller by an TRX_END interrupt. After the transaction has been completed, the transceiver will enter the RX_AACK_ON state. The transceiver will only re-enter the RX_AACK_NOCLK state when the SLP_TR has been reset to "0", and afterwards set to "1" again.

If the transceiver is in the RX_AACK_NOCLK state, and the SLP_TR pin is reset to "0", it will enter the RX_AACK_ON state, and it will again start to supply the micro-controller with the clock signal.



6. Functional Description

6.1. RSSI/Energy Detection

The internal limiter amplifier provides an RSSI value which reflects the current receive signal strength at the antenna pin of the AT86RF230. The RSSI is a 5-bit value indicating the receive power in steps of 3 dB (see register 0x06), and is updated every 2 μ s.

The receiver ED measurement is used with the channel-scan algorithm. An ED request (write access to register 0x07) as defined by the IEEE 802.15.4 standard has a measurement time of 128 μ s. The ED measurement result is accessible after the measurement time at register 0x07 (PHY_ED_LEVEL). With every frame reception (SFD detection), an ED measurement is automatically started. The ED measurement result has the same range as the RSSI value (register 0x06), but with a 1 dB resolution.

6.2. Link Quality Indication

The IEEE 802.15.4 standard defines the link quality indication (LQI) measurement as a “characterization of the strength and/or quality of a received packet”. The LQI measurement of the AT86RF230 is implemented as a characterization of both the quality and signal strength. An average correlation value of multiple symbols is calculated and appended to each frame after scaling to a value ranging from 0 to 255. The minimum LQI value of 0 is associated with a low signal quality, resulting from high signal distortions, and/or a signal strength that is below the receiver sensitivity. The maximum value of 255 is associated with a signal strength higher than the receiver sensitivity and a high signal quality resulting from low signal distortions. Signal distortions are mainly generated by interference and multipath propagation.

6.3. Clear Channel Assessment

The IEEE 802.15.4 standard defines three clear channel assessment (CCA) modes:

- Mode 1: energy above threshold only
- Mode 2: carrier sense only
- Mode 3: carrier sense with energy above threshold

All three modes are available in AT86RF230. The modes are configurable via register 0x08 (PHY_CC_CCA). A CCA request is initiated by writing to bit 7 in register 0x08 (PHY_CC_CCA). After the CCA evaluation time of 128 μ s, the CCA result is accessible at register 0x01 (TRX_STATUS) bits 6 and 7. Bit 7 indicates whether the CCA measurement is finished or not, bit 6 indicates a busy (bit 6 = 0) or clear channel. (bit 6 = 1)

The CCA modes are further configurable using register 0x09 (CCA_THRES).

The 4-bit value CCA_CS_THRES can be used for fine tuning the sensitivity of the CCA carrier sense algorithm. Higher values increase the probability of clear channel detection.

The other 4-bit value (CCA_ED_THRES) of register 0x09 (CCA_THRES) defines the received power threshold of the “energy above threshold” algorithm. Any received power above this level will indicate a busy channel. The threshold is calculated by $-91+2 \cdot \text{CCA_ED_THRES}$ [dBm], resulting in a range of -91 dBm to -61 dBm.

6.4. Voltage Regulators

Two identical low-dropout voltage regulators are integrated within the AT86RF230. The AVREG provides the regulated 1.8V supply voltage for the analog section and the DVREG supplies the low-voltage digital section. A simplified schematic is shown in **Figure 6-1**. The voltage regulators are connected internally to the external unregulated supply voltage VDD. The regulated output voltage is available on pin VDEC1 or VDEC2. External decoupling capacitors should be connected to these pins to stabilize the regulated supply voltage. A decoupling capacitor value of 1 μ F is recommended for stable operation of the voltage regulators (see chapter 9), but it can

range from 400 nF to 10 μ F. A higher capacitor value provides better voltage stability, but increases the voltage regulator settling time.

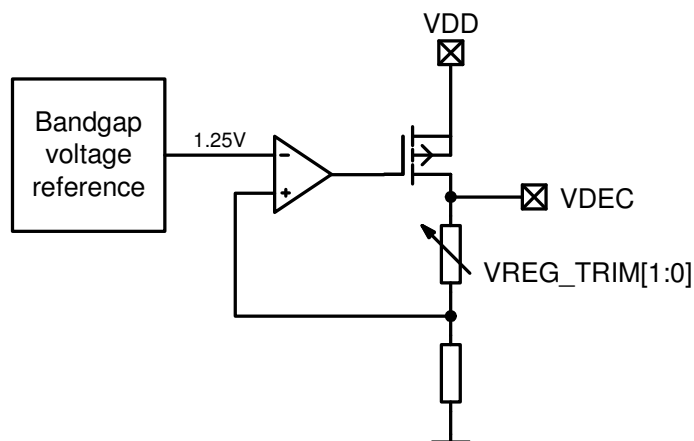

Figure 6-1. Simplified Schematic of VREG

The voltage regulators can be configured using the register 0x10 (VREG_CTRL). The read-only bit values AVDD_OK = 1 and DVDD_OK = 1 indicate a stable, regulated supply voltage.

It is possible to use external voltage regulators instead of the internal regulators. For this special application the internal regulators need to be switched off by setting the register bits to the values AVREG_EXT = 1 and DVREG_EXT = 1. A regulated external supply voltage of 1.8V needs to be connected to the pins VDEC1 and VDEC2. When turning on the external supply, ensure a sufficiently long stabilization time before interacting with the AT86RF230.

6.5. Battery Monitor

The battery monitor (BATMON) detects and signals a low battery or supply voltage. This is done by comparing the current voltage on the VDD pins with a programmable internal threshold voltage. **Figure 6-2** shows the simplified schematic of the BATMON with the most important input and output signals.

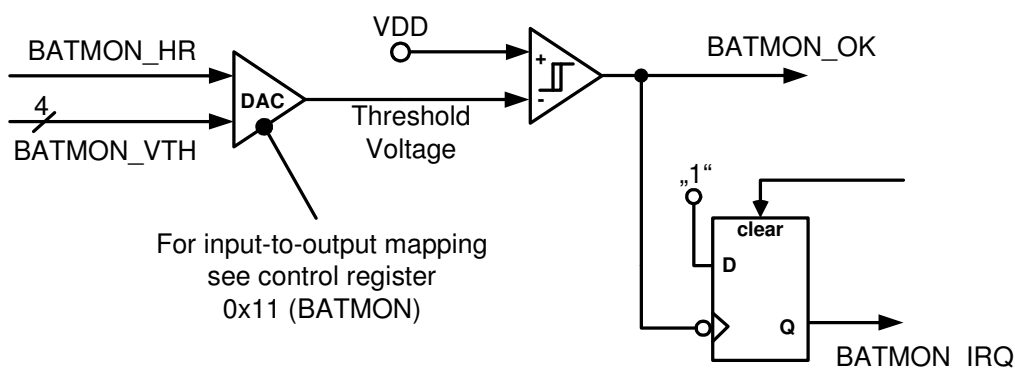

For input-to-output mapping see control register 0x11 (BATMON)

Figure 6-2. Simplified Schematic of BATMON



The BATMON can be configured using the register 0x11 (BATMON). BATMON_VTH[3:0] sets the threshold voltage. It is programmable with a resolution of 75 mV in the upper voltage range (BATMON_HR = 1) and with a resolution of 50 mV in the lower voltage range (BATMON_HR = 0). The signal-bit BATMON_OK indicates the current value of the battery voltage:

- If BATMON_OK is "0", the battery voltage is lower than the threshold voltage
- If BATMON_OK is "1", the battery voltage is higher than the threshold voltage

Furthermore, an interrupt (IRQ7) is automatically generated when the battery voltage falls below the programmed threshold (see control register 0x0F and 0x0E). The interrupt appears only when BATMON_OK changes from "1" to "0". No interrupt will be generated when:

- the battery voltage is under the default 1.8V threshold at power up (BATMON_OK was never "1"), or
- a new threshold is set, which is above the current battery voltage (BATMON_OK remains "0").

After setting a new threshold, the value BATMON_OK should be read out to verify the current supply voltage value.

When the battery voltage is close to the programmed threshold voltage, noise or temporary voltage drops can generate a lot of unwanted interrupts initiated by a toggling BATMON_OK signal. To avoid this:

- disable the IRQ7-bit in IRQ mask register after the first interrupt and treat the battery as empty, or
- set a lower threshold value after the first interrupt.

Note that the battery monitor is inactive during PON and SLEEP modes, see control register 0x01 (TRX_STATUS).

6.6. Crystal Oscillator

The crystal oscillator generates the reference frequency for the AT86RF230. All other internally-generated frequencies in the transceiver are derived from this unique frequency. Therefore the overall system performance is mainly based on the accuracy of this reference frequency. The external components of the crystal oscillator should be selected carefully and the related board layout should be done meticulously.

The register 0x12 (XOSC_CTRL) provides access to the control signals of the oscillator. Basically, two operating modes are supported. A reference frequency can be fed to the internal circuitry by using an external clock reference or by setting up the integrated oscillator as described in **Figure 6-3**.

Using the internal oscillator, the oscillation frequency strongly depends on the load capacitance seen by the crystal between the crystal pins XTAL1 and XTAL2. The total load capacitance must be equal to the specified load capacitance CL of the crystal itself. It consists of the external capacitors CX and parasitic capacitances connected to the XTAL nodes. In **Figure 6-3**, all parasitic capacitances, such as PCB stray capacitances and the pin input capacitance, are summarized to C_{PAR}. Additional internal trimming capacitors C_{TRIM} are available. Any value in the range from 0 pF to 4.8 pF with a 0.3 pF resolution is selectable using the register bits XTAL_TRIM[3:0]. To calculate the total load capacitance, the following formula can be used $CL = 0.5 * (CX + C_{TRIM} + C_{PAR})$.

The trimming capacitors provide the possibility of an easy adjustment of frequency changes caused by production process variations or by tolerances of the external components. Note that the oscillation frequency can be reduced only by increasing the trimming capacitance. The frequency deviation caused by one unit of C_{TRIM} decreases with increasing crystal load capacitor values.

An amplitude control circuit is included to ensure stable operation with different operating conditions and different crystal types. A high current during the amplitude build-up phase guarantees a low start-up time. At stable operation, the current is reduced to the amount necessary for a robust operation. This also keeps the drive level of the crystal low.

Generally, crystals with a higher load capacitance are less sensitive to parasitic pulling effects caused by external component variations or by variations of board and circuit parasitics. On the other hand, a larger crystal load capacitance results in a longer start-up time and a higher steady state current consumption.

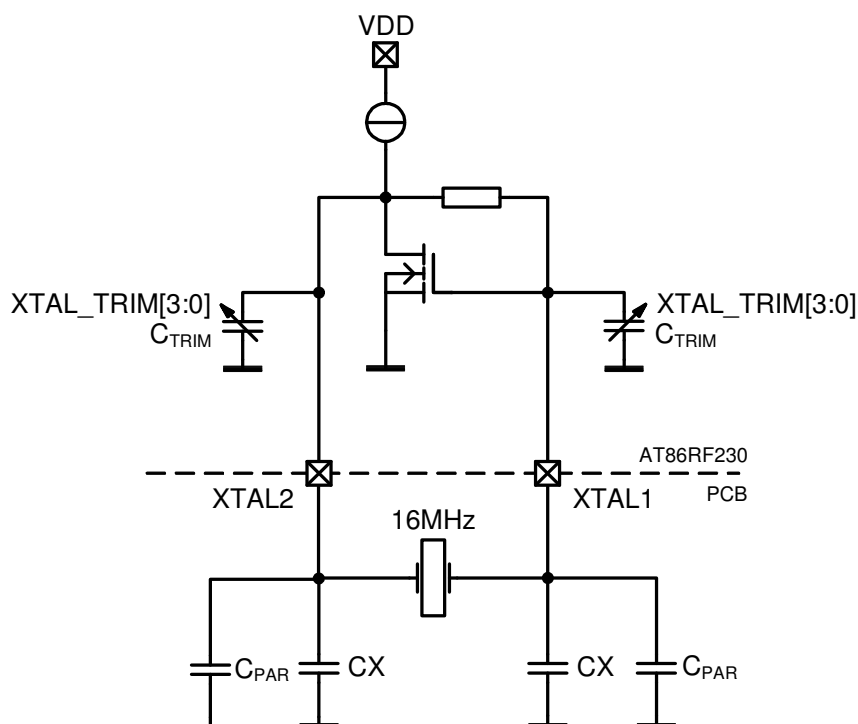

Figure 6-3. Simplified XOSC Schematic with External Components

When using an external reference frequency, the signal needs to be connected to pin XTAL1 as indicated in **Figure 6-4** and the register bits XTAL_MODE needs to be set to the external oscillator mode. The oscillation amplitude shouldn't be larger than 500 mV, peak-to-peak.

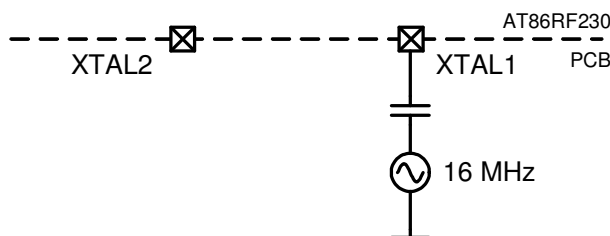

Figure 6-4. Setup for Using an External Frequency Reference

6.7. PLL Frequency Synthesizer

The synthesizer of the AT86RF230 is implemented as a fractional-N PLL. Two calibration loops ensure correct functionality within the specified operating limits.

The center frequency control loop ensures a correct center frequency of the VCO for the currently programmed channel. The center frequency calibration algorithm can be started manually by setting PLL_CF_START = 1 of register 0x1A (PLL_CF). The result of the calibration is also available in this register.

The delay calibration unit compensates the phase errors inherent in fractional-N PLLs. Using this technique, unwanted spurious frequency components beside the RF carrier are suppressed, and the PLL behaves almost like an integer-N PLL. A calibration cycle can be initiated by setting the register bit PLL_DCU_START = 1 of the register 0x1B (PLL_DCU). The calibration result is written to the register bits PLL_DCUIW.



Both calibration routines will be initiated automatically when the PLL is turned on. Additionally, the center frequency calibration is running when the PLL is programmed to a different channel (register 0x08 bits [4:0]). If the PLL is not turned off for a long time, the control loops should be manually initiated from time to time. The calibration interval depends on environment temperature variations but should not be longer than 5 min.

6.8. Automatic Filter Tuning

The filter-tuning unit is a separate building block within the AT86RF230. A calibration cycle is initiated automatically when entering the TRX_OFF state from either the SLEEP, RESET or P_ON states. The result of the calibration is the 6-bit word FTNV, and is written to the register 0x18 (FTN_CTRL).

The filter-tuning value FTNV is used to provide a stable SSBF transfer function and PLL loop-filter time constant independent of temperature effects and part-to-part variations.

It is possible to trigger the calibration algorithm manually by setting the register bit FTN_START = 1.

7. PHY to Micro-Controller Interface

In the following paragraphs, the PHY to micro-controller interface is defined. The SPI protocol and timing access are shown, as well as buffer access modes with examples.

Controllers with an SPI interface such as an AVR will work with the AT86RF230 interface. The SPI interface is used for both register programming as well as for frame transfer. The additional control signals are connected to the GPIO interface of the controller. **Figure 7-1** shows the signals which need to be connected between the controller and the transceiver. The CLKM signal can be used as a controller main clock (synchronous mode) or as software timer reference (asynchronous mode).

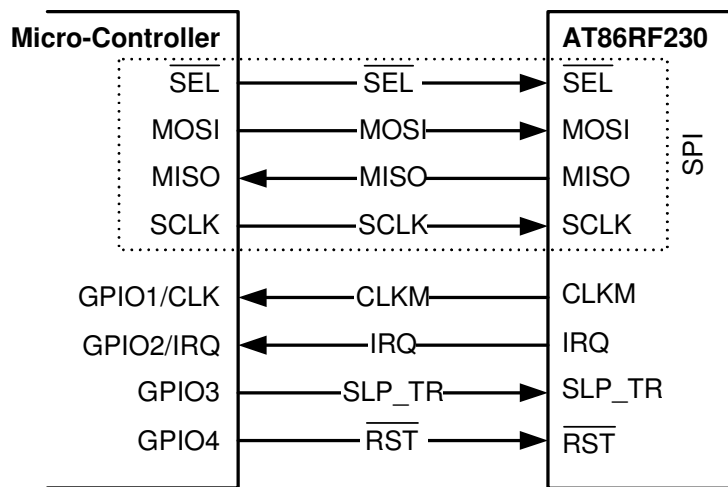

Figure 7-1. PHY-HOST Interface

7.1. SPI Protocol

SPI is used to program control registers as well as to transfer data frames between the controller and the AT86RF230. The additional signals CLKM, IRQ, SLP_TR and $\overline{\text{RST}}$ are connected to the GPIO interface of the controller.

The internal 128-byte frame buffer can keep one TX or one RX frame of maximum length at a time. This offers a very flexible data rate over the SPI interface.

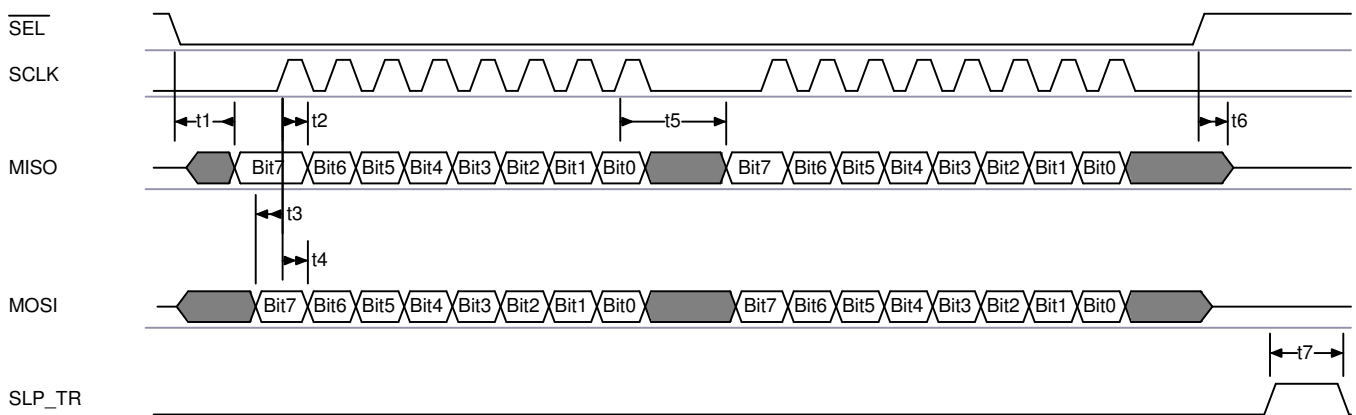

Figure 7-2. SPI Timing



The interface is designed to work in synchronous or asynchronous mode. In synchronous mode, the CLKM output of the transceiver IC is used as the master clock of the controller. The SPI clock can be any integer-divided clock ratio up to 8 MHz.

Nevertheless, usage of an independent controller clock for an asynchronous interface is possible. In asynchronous mode, the maximum SPI clock speed is limited to 7.5 MHz. The external CLKM output signal is not required and can be disabled.

$\overline{\text{SEL}}$ enables the MISO output driver of the AT86RF230. If the driver is disabled, there is no internal pull-up resistor connected to it. Driving the appropriate signal level must be ensured by the master device or an external pull-up resistor.

The SPI is a byte-oriented serial interface. All bytes are transferred MSB first. Every SPI transfer starts with $\overline{\text{SEL}} = 0$ and this signal is asserted low as long as one consecutive SPI access occurs. One consecutive access includes two or more bytes depending on the access mode described later. If $\overline{\text{SEL}} = 0$ goes high before the end of one complete access, the internal bit counter is reset and the transferred data are lost.

Both sides of the interface (master and slave) contain an 8-bit shift register. The master starts the transfer by asserting $\overline{\text{SEL}} = 0$. After the 8-bit shift register is loaded, the master generates eight SPI clocks in order to transfer the data to the slave, and at the same time the slave transmits one byte to the master shift register. If the master wants to receive one byte of data it must also transmit one byte to the slave. Every transfer starts with a command byte. This command byte contains the access mode information as well as additional mode-dependent bits. During command byte transfer, the AT86RF230 returns a byte containing "0".

Bit 7	Bit 6 (R/W)	Bit 5	Bit 4	Bit 3	Bit 2	Bit 1	Bit 0	Mode
1	0	Register address [5:0]						Short mode (register read access)
1	1	Register address [5:0]						Short mode (register write access)
0	0	1	Reserved					Frame receive mode
0	1	1	Reserved					Frame transmit mode
0	0	0	Reserved					SRAM read access mode
0	1	0	Reserved					SRAM write access mode

Table 7-1. Interface Access Mode Overview

7.2. Register Access Mode (Short Mode)

The register access mode is a two-byte read/write operation. The first byte contains the control information (mode identifier bit 7, read/write select bit 6, and a 6-bit address). The second byte contains the read or write data. In this mode a maximum of 64 consecutive registers can be addressed.

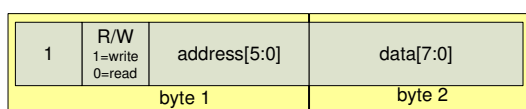

Figure 7-3. Register Short Mode Access

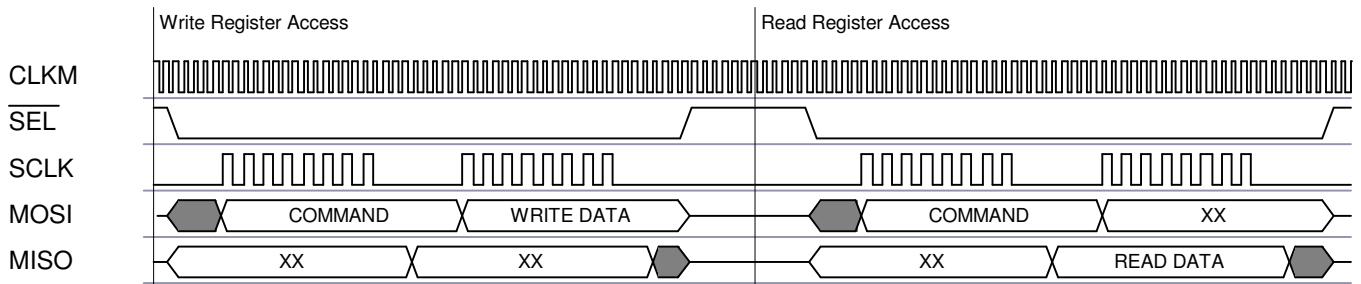

Figure 7-4. SPI Register Access Sequence

7.3. Frame Buffer Access Modes (Long Modes)

These modes are used to upload or download frames as well as access the frame buffer directly. Each transfer starts with a control byte. If this byte indicates a frame upload or download, the next byte indicates the frame length followed by the PSDU data. In receive mode, after the PSDU data has been received, one more byte is attached, containing LQI information.

The number of bytes for one frame access must be calculated by the controller as follows:

- Transmit:** byte_count = command byte + frame length byte + frame length
- Receive:** byte_count = command byte + frame length byte + frame length + LQI byte

That means there is a maximum frame buffer access of 129 bytes for TX and 130 bytes for RX.

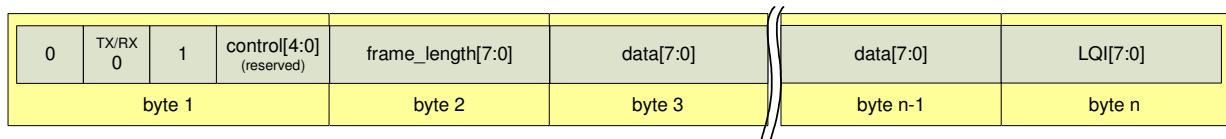

Figure 7-5. Frame Receive Mode

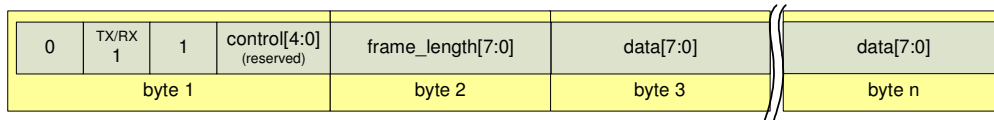

Figure 7-6. Frame Transmit Mode

If the control byte indicates SRAM access mode, the next byte contains the start address. As long as $\overline{\text{SEL}}$ is low, every subsequent byte read or write increments the address counter of the frame buffer.

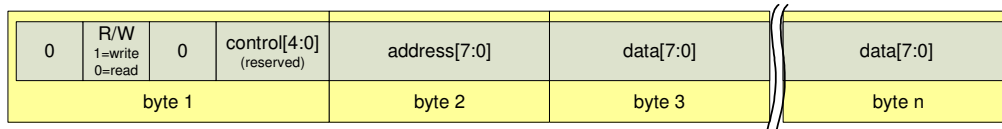

Figure 7-7. SRAM Access Mode

7.4. Frame Receive Procedure

The following transactions are required to receive a frame over the SPI:

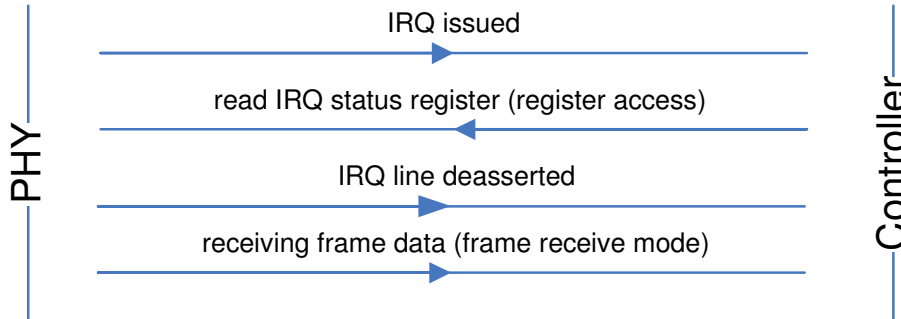

Figure 7-8. Receive Frame Transactions Between AT86RF230 and Controller

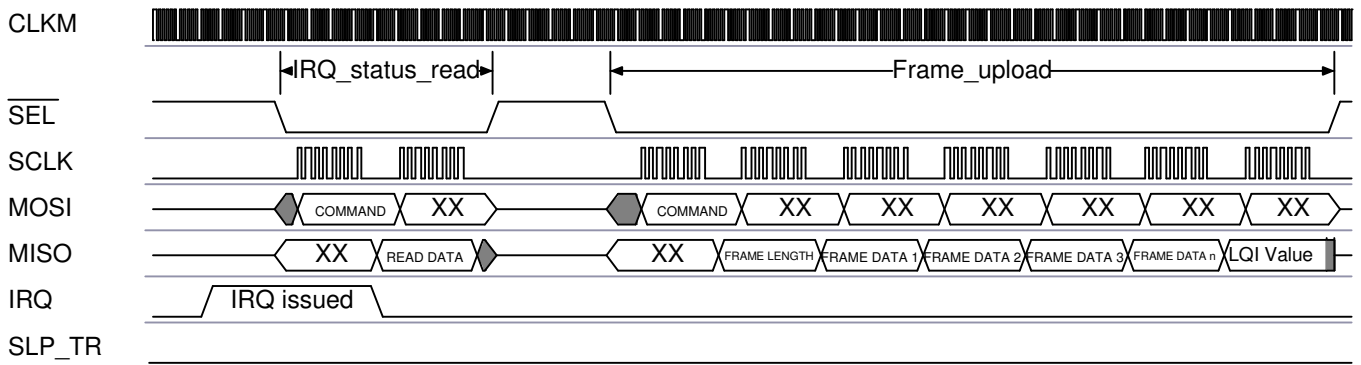

Figure 7-9. Frame Receive Sequence

7.5. Frame Transmit Procedure

The following transactions are required to transmit a frame over SPI:

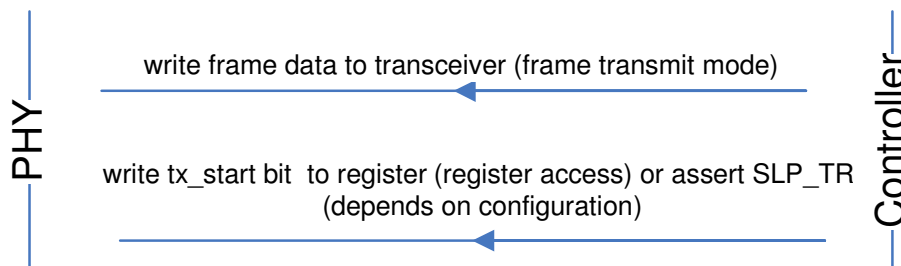

Figure 7-10. Transmit Frame Transactions Between AT86RF230 and Controller

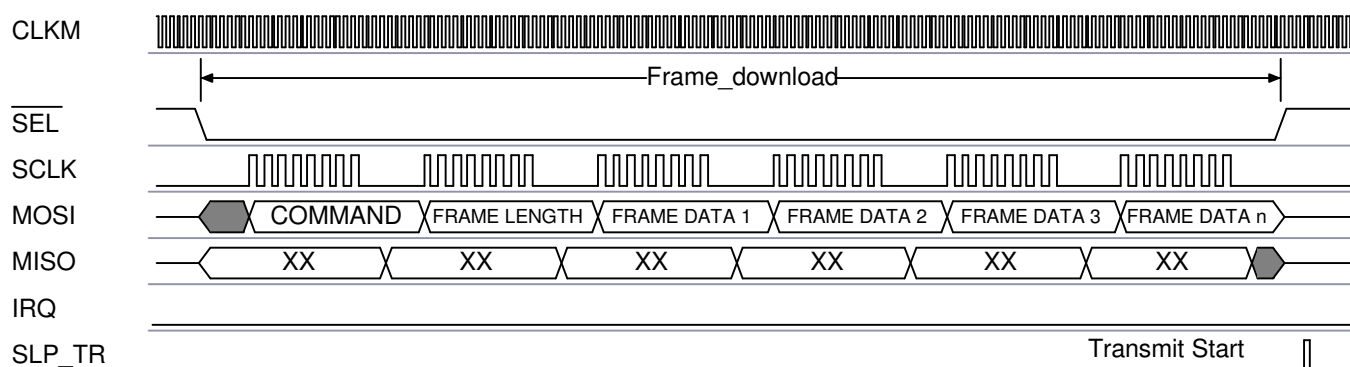

Figure 7-11. Frame Transmit Sequence (SLP_TR Assertion Starts Transmission)

7.6. Sleep/Wake-up and Transmit Signal

The SLP_TR signal is a multi-functional pin. It can be used as transmit start or as a sleep signal. The function of the pin depends on the transceiver status.

Transceiver Status	Pin Function	Description
TRX_OFF	Sleep	Forces the transceiver into SLEEP mode
RX_ON	Disable CLKM	Forces the transceiver into RX_ON_NOCLOCK state and disables CLKM
PLL_ON	TX start	Start frame transmission
TX_ARET_ON	TX start	Start of frame retry
RX_AACK_ON	TX start	Start of frame acknowledge

Table 7-2. SLP_TR Multi-functional Pin States

The pin has no function if the transceiver is in other modes.

If used as a sleep signal, releasing the pin SLP_TR = 0 forces the transceiver into TRX_OFF mode and enables the main clock. If used as a transmit start signal, the low-to-high edge starts the transmission of a frame stored in the frame buffer.

From the application point of view, there are two possible power-down scenarios supported by the AT86RF230. Either both the controller and the AT86RF230 are powered down, or the AT86RF230 listens for an incoming frame and only the controller is powered down.

The first power-down scenario is shown in **Figure 7-12**. The controller forces the AT86RF230 to SLEEP mode by setting SLP_TR to “1” when the transceiver is in TRX_OFF mode. The main clock at pin CLKM will be switched off after 35 clock cycles. This enables the controller to complete its power-down routine and prevent dead-lock situations. The AT86RF230 will awaken when the controller releases the pin SLP_TR. This concept provides the lowest possible power consumption.

If an incoming frame is expected and no other application is running on the controller, the controller itself can be powered down without the risk of missing an incoming frame. This scenario is shown in **Figure 7-13**. In RX_ON state, the CLKM pin will be switched off after 35 clock cycles when the pin SLP_TR is set to “1”. The start of a frame reception will be signaled by an RX_START IRQ and the clock will be switched on again.

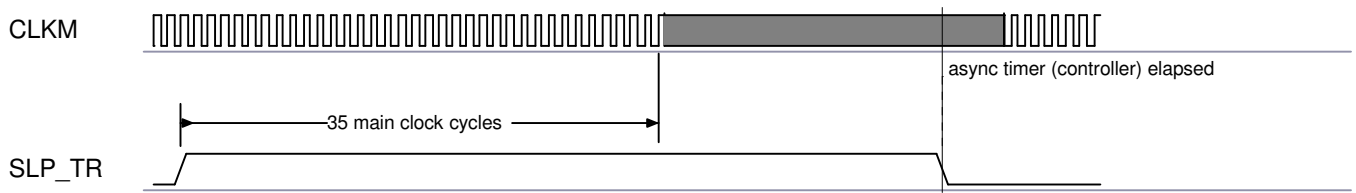

Figure 7-12. Sleep and Wake-up Initiated by Asynchronous Controller Timer Output

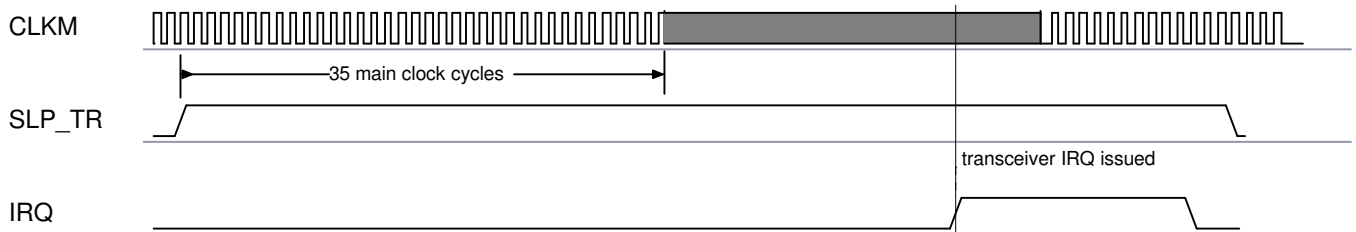

Figure 7-13. Wake-up Initiated by Transceiver Interrupt

7.7. Interrupt Logic

The AT86RF230 can differentiate between six interrupt events. Each interrupt can be enabled or disabled by writing the corresponding bit to the interrupt mask register. All six internal interrupt lines are combined via logical “OR” to one external interrupt line. Internally, each interrupt is stored in a separate bit of the interrupt status register. If the external interrupt line is set, the controller must first read the interrupt status register to determine the source of the interrupt. A read access to this register clears the interrupt status register and also the external interrupt line. The interrupt will not be cleared automatically when the event that caused the IRQ is not valid anymore. Exception: the PLL_LOCK IRQ will clear the PLL_UNLOCK IRQ and vice versa.

For a detailed description of the interrupt status register, please refer to register 0x0F (IRQ_STATUS).

Note: After a reset signal, all interrupts are enabled. Special settings in the register 0x0E (IRQ_MASK) need to be renewed.

8. Control Registers

The AT86RF230 provides a register space of 64 8-bit registers, which is used to configure the IC as well as to store signaling information read by the firmware.

Note that all registers not mentioned within the following table are reserved for internal use and must not be written to. When writing to a non-reserved register, any individual bits of that register marked as reserved can only be overwritten by their reset value.

Reg.-Addr.	Register Name	Description
0x01	TRX_STATUS	Transceiver status, CCA result
0x02	TRX_STATE	State/mode control
0x03	TRX_CTRL_0	Driver current and controller clock setting
0x05	PHY_TX_PWR	TX power setting
0x06	PHY_RSSI	RSSI value
0x07	PHY_ED_LEVEL	RX energy level
0x08	PHY_CC_CCA	CCA mode configuration, CCA request, channel setting
0x09	CCA_THRES	CCA_ED and CCA_CS threshold
0x0E	IRQ_MASK	Interrupt mask
0x0F	IRQ_STATUS	Interrupt status
0x10	VREG_CTRL	Voltage regulator control
0x11	BATMON	Battery monitor control
0x12	XOSC_CTRL	Crystal oscillator control
0x18	FTN_CTRL	Filter tuning control
0x1A	PLL_CF	PLL center frequency calibration
0x1B	PLL_DCU	PLL delay calibration
0x1C	PART_NUM	Part ID
0x1D	VERSION_NUM	Version ID
0x1E	MAN_ID_0	Manufacturer ID, lower 8 bits
0x1F	MAN_ID_1	Manufacturer ID, higher 8 bits
0x20	SHORT_ADDR_0	Short address for address recognition
0x21	SHORT_ADDR_1	Short address for address recognition
0x22	PAN_ID_0	PAN address for address recognition
0x23	PAN_ID_1	PAN address for address recognition
0x24	IEEE_ADDR_0	Current node IEEE address for address recognition
0x25	IEEE_ADDR_1	Current node IEEE address for address recognition
0x26	IEEE_ADDR_2	Current node IEEE address for address recognition
0x27	IEEE_ADDR_3	Current node IEEE address for address recognition
0x28	IEEE_ADDR_4	Current node IEEE address for address recognition

Reg.-Addr.	Register Name	Description
0x29	IEEE_ADDR_5	Current node IEEE address for address recognition
0x2A	IEEE_ADDR_6	Current node IEEE address for address recognition
0x2B	IEEE_ADDR_7	Current node IEEE address for address recognition
0x2C	XAH_CTRL	Retries value control
0x2D	CSMA_SEED_0	CSMA seed value
0x2E	CSMA_SEED_1	CSMA seed value

Table 8-1. Configuration registers overview

Bit	Field Name	Reset	R/W	Comments
7	CCA_DONE	0	R	1'd0: CCA calculation in progress 1'd1: CCA calculation done
6	CCA_STATUS	0	R	Indicates an idle channel from CCA module. CHANNEL_IDLE: 1'd0: channel is busy 1'd1: channel is idle
5		0	R	Reserved
4:0	TRX_STATUS	0	R	Signals the current transceiver status. TRANSCIVER_STATUS: 5'd0: P_ON 5'd1: BUSY_RX 5'd2: BUSY_TX 5'd6: RX_ON 5'd8: TRX_OFF (CLK Mode) 5'd9: PLL_ON (TX_ON) 5'd15: SLEEP 5'd17: BUSY_RX_AACK 5'd18: BUSY_TX_ARET 5'd22: RX_AACK_ON 5'd25: TX_ARET_ON 5'd28: RX_ON_NOCLK 5'd29: RX_AACK_ON_NOCLK 5'd30: BUSY_RX_AACK_NOCLK 5'd31: state transition

Table 8-2. 0x01 - TRX_STATUS

Note: A register read will reset the CCA_STATUS bit and the CCA_DONE bit if a CCA calculation was done (CCA_DONE = 1).

Bit	Field Name	Reset	R/W	Comments
7:5	TRAC_STATUS	0	R	3'd0: SUCCESS 3'd3: CHANNEL_ACCESS_FAILURE 3'd5: NO_ACK All other values are reserved.
4:0	TRX_CMD	0	R/W	Transceiver control commands: 5'd0: NOP 5'd2: TX_START 5'd3: FORCE_TRX_OFF 5'd6: RX_ON 5'd8: TRX_OFF (CLK Mode) 5'd9: PLL_ON (TX_ON) 5'd22: RX_AACK_ON 5'd25: TX_ARET_ON All other values are mapped to NOP.

Table 8-3. 0x02 - TRX_STATE

Note: TRX_CMD = "0" after power on reset (POR).
Frame transmission starts 16 μ s after TX_START command.

Bit	Field Name	Reset	R/W	Comments
7:6	PAD_IO	0	R/W	Set the output driver current of digital pads (except CLKM pad). 2'd0: 2 mA 2'd1: 4 mA 2'd2: 6 mA 2'd3: 8 mA
5:4	PAD_IO_CLKM	1	R/W	Set the output driver current of CLKM. 2'd0: 2 mA 2'd1: 4 mA 2'd2: 6 mA 2'd3: 8 mA
3	CLKM_SHA_SEL	1	R/W	Shadow the CLKM_CTRL clock changes. If the mode is enabled, changes to the CLKM_CTRL bits take effect only when the IC leaves the SLEEP mode. 1'd0: disable (on the fly) 1'd1: enable (shadow)
2:0	CLKM_CTRL	1	R/W	Controls the clock frequency at the CLKM pad. 3'd0: no clock 3'd1: 1 MHz 3'd2: 2 MHz 3'd3: 4 MHz 3'd4: 8 MHz 3'd5: 16 MHz 3'd6: no clock 3'd7: no clock

Table 8-4. 0x03 - TRX_CTRL_0

Bit	Field Name	Reset	R/W	Comments	
7	TX_AUTO_CRC_ON	0	R/W	AUTO_CRC mode: 1'd0: disable 1'd1: enable	
6:4		0	R	Reserved	
3:0	TX_PWR	0	R/W	TX Power Mapping	
				TX Power Setting	Output Power [dBm]
				0	3.0
				1	2.6
				2	2.1
				3	1.6
				4	1.1
				5	0.5
				6	-0.2
				7	-1.2
				8	-2.2
				9	-3.2
				10	-4.2
				11	-5.2
				12	-7.2
				13	-9.2
14	-12.2				
15	-17.2				

Table 8-5. 0x05 - PHY_TX_PWR

Bit	Field Name	Reset	R/W	Comments
7:5		0	R	Reserved
4:0	RSSI	0	R	5'd0: RX input level < -91 dBm 5'd27: RX input level > -10 dBm RSSI is a linear curve on a logarithmic input power scale (dBm) with a 3 dB step width.

Table 8-6. 0x06 - PHY_RSSI

Bit	Field Name	Reset	R/W	Comments
7:0	ED_LEVEL	0	R	ED level for current channel. The min. ED value (0) indicates receiver power less than or equal to -91 dBm. The range is 84 dB with a resolution of 1 dB and an absolute accuracy of ± 5 dB.

Table 8-7. 0x07 - PHY_ED_LEVEL

Note: A write access initiates the ED measurement (ED.request).

Bit	Field Name	Reset	R/W	Comments
7	CCA_REQUEST	0	R/W	1'd1: starts a CCA check (CCA.request) read value always returns with "0"
6:5	CCA_MODE	1	R/W	CCA Mode: 2'd0: Mode 1, energy above threshold 2'd1: Mode 1, energy above threshold 2'd2: Mode 2, carrier sense only 2'd3: Mode 3, carrier sense with energy above threshold
4:0	CHANNEL	11	R/W	Channel: According to IEEE802.15.4 only 11 to 26 are valid. All unused values are reserved.
Channel Mapping				
		Channel Number	Frequency [MHz]	
		11	2405	
		12	2410	
		13	2415	
		14	2420	
		15	2425	
		16	2430	
		17	2435	
		18	2440	
		19	2445	
		20	2450	
		21	2455	
		22	2460	
		23	2465	
		24	2470	
		25	2475	
		26	2480	

Table 8-8. 0x08 - PHY_CC_CCA



Bit	Field Name	Reset	R/W	Comments
7:4	CCA_CS_THRES	12	R/W	Threshold for CCA_CS
3:0	CCA_ED_THRES	7	R/W	An ED value above the threshold signals a busy channel during a CCA_ED measurement.

Table 8-9. 0x09 - CCA_THRES

Note: CCA_ED_THRES: The CCA_ED request will indicate a busy channel, if the measured receive power is above $-91 \text{ dBm} + 2 * \text{CCA_ED_THRES}[\text{dB}]$.

Bit	Field Name	Reset	R/W	Comments
7:0	IRQ_MASK	255	R/W	Mask register for IRQs. If bit is set to high, then the IRQ is enabled. If bit is set to low, then the IRQ is disabled. IRQ_MASK[7] corresponds to IRQ_7. IRQ_MASK[0] corresponds to IRQ_0.

Table 8-10. 0x0E - IRQ_MASK

Note: The occurrence of an interrupt will be signaled over the IRQ wire.

Bit	Field Name	Reset	R/W	Comments
7	IRQ_7	0	R	BAT_LOW: signals low battery
6	IRQ_6	0	R	TRX_UR: signals a FIFO underrun
5	IRQ_5	0	R	Reserved
4	IRQ_4	0	R	Reserved
3	IRQ_3	0	R	TRX_END: signals end of frame (transmit and receive)
2	IRQ_2	0	R	RX_START: signals beginning of receive frame
1	IRQ_1	0	R	PLL_UNLOCK: PLL goes from lock to unlock state
0	IRQ_0	0	R	PLL_LOCK: PLL goes from unlock to lock state

Table 8-11. 0x0F - IRQ_STATUS

Note: The occurrence of an interrupt will be signaled over the IRQ wire. A read access will reset the interrupt bits.

Bit	Field Name	Reset	R/W	Comments
7	AVREG_EXT	0	R/W	1'd0: use internal analog voltage regulator 1'd1: use external voltage regulator
6	AVDD_OK	0	R	1'd0: analog voltage regulator is disabled 1'd1: internal analog voltage is correct and stable
5:4	AVREG_TRIM	0	R/W	Controls the voltage of the analog voltage regulator. 2'd0: 1.80V 2'd1: 1.75V 2'd2: 1.84V 2'd3: 1.88V

Bit	Field Name	Reset	R/W	Comments
3	DVREG_EXT	0	R/W	1'd0: use internal digital voltage regulator 1'd1: use external voltage regulator
2	DVDD_OK	0	R	1'd0: digital voltage regulator is disabled 1'd1: internal digital voltage is correct and stable
1:0	DVREG_TRIM	0	R/W	Controls the voltage of the digital voltage regulator. 2'd0: 1.80V 2'd1: 1.75V 2'd2: 1.84V 2'd3: 1.88V

Table 8-12. 0x10 - VREG_CTRL

Bit	Field Name	Reset	R/W	Comments																																																			
7:6		0	R	Reserved																																																			
5	BATMON_OK	0	R	Result of battery monitor: 1'd0: not valid (VDD < BATMON_VTH) 1'd1: valid (VDD > BATMON_VTH)																																																			
4	BATMON_HR	0	R/W	High range switch (mapping see BATMON_VTH)																																																			
3:0	BATMON_VTH	2	R/W	Threshold voltage: BATMON_VTH Mapping																																																			
				<table border="1"> <thead> <tr> <th>Value</th> <th>Voltage [V] BATMON_HR = "1"</th> <th>Voltage [V] BATMON_HR = "0"</th> </tr> </thead> <tbody> <tr><td>0</td><td>2.550</td><td>1.70</td></tr> <tr><td>1</td><td>2.625</td><td>1.75</td></tr> <tr><td>2</td><td>2.700</td><td>1.80</td></tr> <tr><td>3</td><td>2.775</td><td>1.85</td></tr> <tr><td>4</td><td>2.850</td><td>1.90</td></tr> <tr><td>5</td><td>2.925</td><td>1.95</td></tr> <tr><td>6</td><td>3.000</td><td>2.00</td></tr> <tr><td>7</td><td>3.075</td><td>2.05</td></tr> <tr><td>8</td><td>3.150</td><td>2.10</td></tr> <tr><td>9</td><td>3.225</td><td>2.15</td></tr> <tr><td>10</td><td>3.300</td><td>2.20</td></tr> <tr><td>11</td><td>3.375</td><td>2.25</td></tr> <tr><td>12</td><td>3.450</td><td>2.30</td></tr> <tr><td>13</td><td>3.525</td><td>2.35</td></tr> <tr><td>14</td><td>3.600</td><td>2.40</td></tr> <tr><td>15</td><td>3.675</td><td>2.45</td></tr> </tbody> </table>	Value	Voltage [V] BATMON_HR = "1"	Voltage [V] BATMON_HR = "0"	0	2.550	1.70	1	2.625	1.75	2	2.700	1.80	3	2.775	1.85	4	2.850	1.90	5	2.925	1.95	6	3.000	2.00	7	3.075	2.05	8	3.150	2.10	9	3.225	2.15	10	3.300	2.20	11	3.375	2.25	12	3.450	2.30	13	3.525	2.35	14	3.600	2.40	15	3.675	2.45
Value	Voltage [V] BATMON_HR = "1"	Voltage [V] BATMON_HR = "0"																																																					
0	2.550	1.70																																																					
1	2.625	1.75																																																					
2	2.700	1.80																																																					
3	2.775	1.85																																																					
4	2.850	1.90																																																					
5	2.925	1.95																																																					
6	3.000	2.00																																																					
7	3.075	2.05																																																					
8	3.150	2.10																																																					
9	3.225	2.15																																																					
10	3.300	2.20																																																					
11	3.375	2.25																																																					
12	3.450	2.30																																																					
13	3.525	2.35																																																					
14	3.600	2.40																																																					
15	3.675	2.45																																																					

Table 8-13. 0x11 - BATMON



Bit	Field Name	Reset	R/W	Comments
7:4	XTAL_MODE	15	R/W	XTAL Modes: 4'd0: switch off 4'd4: external oscillator 4'd15: internal oscillator All other modes are reserved and should not be used.
3:0	XTAL_TRIM	0	R/W	Binary coded capacitance array for XTAL trimming. Values: 0 pF, 0.3 pF, ..., 4.8 pF

Table 8-14. 0x12 - XOSC_CTRL

Bit	Field Name	Reset	R/W	Comments
7	FTN_START	0	R/W	1'd1: Initiates filter calibration cycle If filter calibration is finished, read value is "0"
6		1	R/W	Reserved
5:0	FTNV	24	R/W	Filter tuning value

Table 8-15. 0x18 - FTN_CTRL

Bit	Field Name	Reset	R/W	Comments
7	PLL_CF_START	0	R/W	1'd1: Initiates PLL center frequency calibration cycle If frequency calibration is finished, read value is "0"
6:4		5	R/W	Reserved
3:0	PLL_CF	15	R/W	VCO center frequency control word

Table 8-16. 0x1A – PLL_CF

Bit	Field Name	Reset	R/W	Comments
7	PLL_DCU_START	0	R/W	1'd1: Initiates PLL delay cell calibration cycle If delay cell calibration is finished, read value is "0"
6		0	R	Reserved
5:0	PLL_DCUW	32	R/W	Delay cell control word

Table 8-17. 0x1B – PLL_DCU

Bit	Field Name	Reset	R/W	Comments
7:0	PART_NUM	2	R	The device part number. 8'd2: AT86RF230 All other values are reserved

Table 8-18. 0x1C - PART_NUM

Bit	Field Name	Reset	R/W	Comments
7:0	VERSION_NUM	1	R	The device version number.

Table 8-19. 0x1D - VERSION_NUM

Bit	Field Name	Reset	R/W	Comments
7:0	MAN_ID_0	31	R	JEDEC manufacturer ID is 32'h 00_00_00_1F for Atmel, bits[7:0]

Table 8-20. 0x1E - MAN_ID_0

Bit	Field Name	Reset	R/W	Comments
7:0	MAN_ID_1	0	R	JEDEC manufacturer ID is 32'h 00_00_00_1F for Atmel, bits[15:8]

Table 8-21. 0x1F - MAN_ID_1

Bit	Field Name	Reset	R/W	Comments
7:0	SHORT_ADDR_0	0	R/W	Lower 8 bits of short address for address recognition, bits[7:0]

Table 8-22. 0x20 - SHORT_ADDR_0

Bit	Field Name	Reset	R/W	Comments
7:0	SHORT_ADDR_1	0	R/W	Higher 8 bits of short address for address recognition, bits[15:8]

Table 8-23. 0x21 - SHORT_ADDR_1

Bit	Field Name	Reset	R/W	Comments
7:0	PAN_ID_0	0	R/W	Lower 8 bits of PAN address for address recognition, bits[7:0]

Table 8-24. 0x22 - PAN_ID_0

Bit	Field Name	Reset	R/W	Comments
7:0	PAN_ID_1	0	R/W	Higher 8 bits of PAN address for address recognition, bits[15:8]

Table 8-25. 0x23 - PAN_ID_1

Bit	Field Name	Reset	R/W	Comments
7:0	IEEE_ADDR_0	0	R/W	Lower 8 bits of IEEE address for address recognition, bits[7:0]

Table 8-26. 0x24 - IEEE_ADDR_0

Bit	Field Name	Reset	R/W	Comments
7:0	IEEE_ADDR_1	0	R/W	8 bits of IEEE address for address recognition, bits[15:8]

Table 8-27. 0x25 - IEEE_ADDR_1

Bit	Field Name	Reset	R/W	Comments
7:0	IEEE_ADDR_2	0	R/W	8 bits of IEEE address for address recognition, bits[23:16]

Table 8-28. 0x26 - IEEE_ADDR_2



Bit	Field Name	Reset	R/W	Comments
7:0	IEEE_ADDR_3	0	R/W	8 bits of IEEE address for address recognition, bits[31:24]

Table 8-29. 0x27 - IEEE_ADDR_3

Bit	Field Name	Reset	R/W	Comments
7:0	IEEE_ADDR_4	0	R/W	8 bits of IEEE address for address recognition, bits[39:32]

Table 8-30. 0x28 - IEEE_ADDR_4

Bit	Field Name	Reset	R/W	Comments
7:0	IEEE_ADDR_5	0	R/W	8 bits of IEEE address for address recognition, bits[47:40]

Table 8-31. 0x29 - IEEE_ADDR_5

Bit	Field Name	Reset	R/W	Comments
7:0	IEEE_ADDR_6	0	R/W	8 bits of IEEE address for address recognition, bits[55:48]

Table 8-32. 0x2A - IEEE_ADDR_6

Bit	Field Name	Reset	R/W	Comments
7:0	IEEE_ADDR_7	0	R/W	Higher 8 bits of IEEE address for address recognition, bits[63:56]

Table 8-33. 0x2B - IEEE_ADDR_7

Bit	Field Name	Reset	R/W	Comments
7:4	MAX_FRAME_RETRIES	3	R/W	Number of retransmission attempts in ARET mode before the transaction gets cancelled.
3:1	MAX_CSMA_RETRIES	4	R/W	Number of retries in ARET mode to repeat the CSMA/CA procedures before the ARET procedure gives up.
0		0	R/W	Reserved

Table 8-34. 0x2C - XAH_CTRL

Bit	Field Name	Reset	R/W	Comments
7:0	CSMA_SEED_0	234	R/W	Lower 8 bits of CSMA_SEED, bits[7:0] Seed for the random number generator in the CSMA/CA algorithm

Table 8-35. 0x2D - CSMA_SEED_0

Bit	Field Name	Reset	R/W	Comments
7:6	MIN_BE	3	R/W	Minimum back-off exponent in the CSMA/CA algorithm.
5:4		0	R	Reserved
3	I_AM_COORD	0	R/W	Use for address filtering within AACK mode (PAN coordinator) 1'd0: disable 1'd1: enable
2:0	CSMA_SEED_1	2	R/W	Higher 3 bits of CSMA_SEED, bits[10:8] Seed for the random number generator in the CSMA/CA algorithm

Table 8-36. 0x2E - CSMA_SEED_1

9. Application Circuit

An application circuit with a single-ended RF connector is shown in **Figure 9-1**. An SMD-balun transforms the 100Ω differential RF inputs/outputs of the AT86RF230 to a 50Ω single ended RF port. The capacitors C1 and C2 form a DC-block.

Power supply decoupling capacitors (CB2, CB4) are connected to the analog (28) and the digital supply pin (15). Capacitors CB1 and CB3 are load capacitors for the analog and digital voltage regulators. They ensure a stable operation of the low-voltage parts of the AT86RF230. All decoupling capacitors should be placed as close as possible to the AT86RF230 pin and need to have a low-resistance and low-inductive connection to ground to achieve the best performance.

The crystal (XTAL), the two load capacitors (CX1, CX2), and the internal circuitry connected to pins XTAL1 and XTAL2 form the crystal oscillator. To achieve the best accuracy and stability of the reference frequency, large stray capacitances should be avoided.

Cross coupling of digital signals to the crystal pins or the RF pins can degrade system performance.

Designator	Description	Value	Manufacturer	Manuf. Part Number
B1	SMD balun	2.4 GHz	Wuerth	748421245
CB1	DC-blocking capacitor	1 μF		
CB2	DC-blocking capacitor	1 μF		
CB3	DC-blocking capacitor	1 μF		
CB4	DC-blocking capacitor	1 μF		
CX1	Crystal load capacitor	12 pF		
CX2	Crystal load capacitor	12 pF		
C1	RF-coupling capacitor	22 pF		
C2	RF-coupling capacitor	22 pF		
XTAL	Crystal	CX-4025 16 MHz SX-4025 16 MHz	ACAL Taitjen Siward	XWBBPL-F-1 A207-011

Table 9-1. Bill of Materials

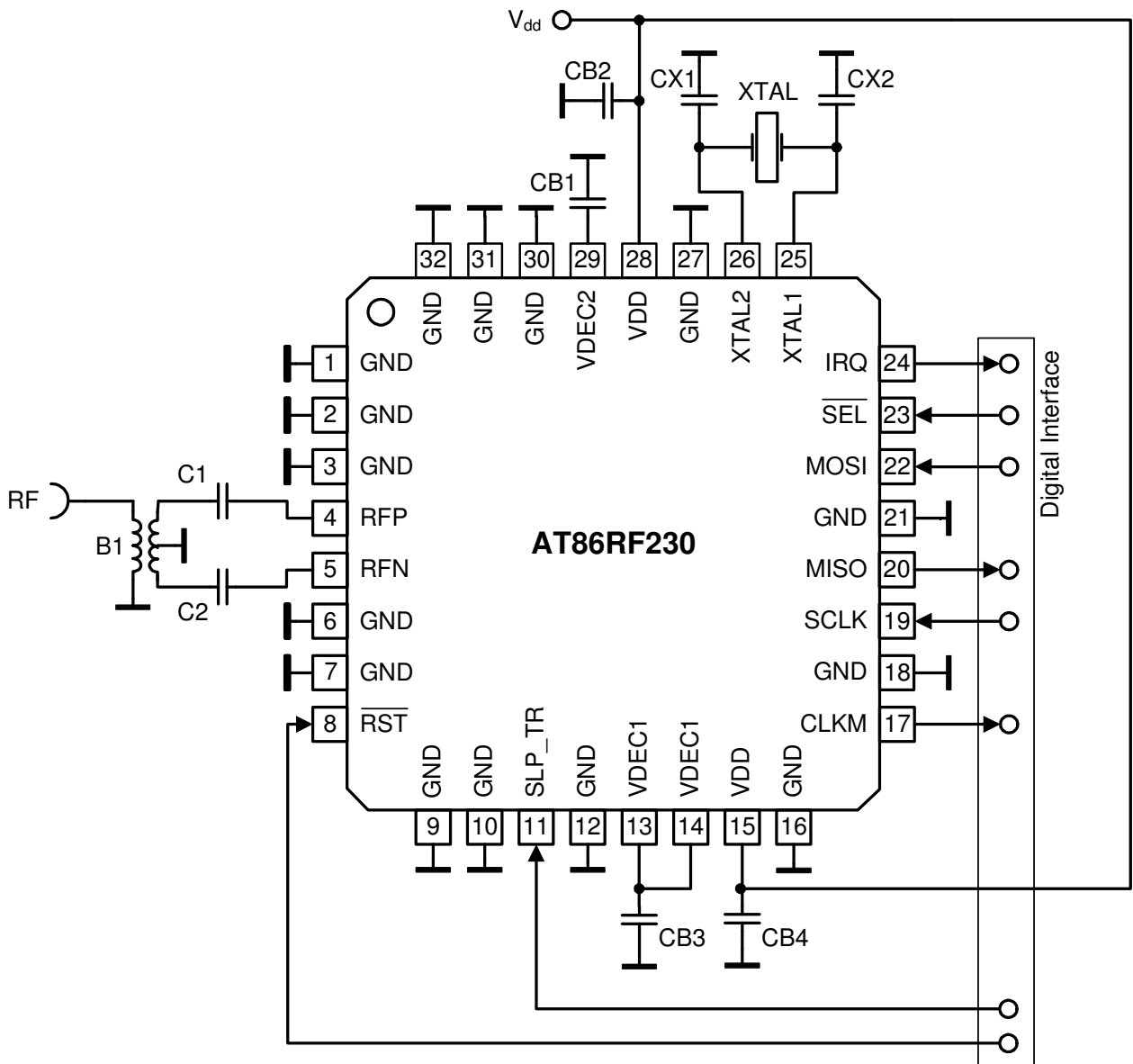

Figure 9-1. Application Schematic



10. Pin Configuration

Number	Name	Type	Description
1	GND	Ground	Analog ground
2	GND	Ground	Analog ground
3	GND	Ground	Ground for RF signals
4	RFP	RF I/O	Differential RF signal
5	RFN	RF I/O	Differential RF signal
6	GND	Ground	Ground for RF signals
7	GND	Ground	Digital ground
8	$\overline{\text{RST}}$	Digital input	Chip reset pin, active low
9	GND	Ground	Digital ground
10	GND	Ground	Digital ground
11	SLP_TR	Digital input	Controls sleep, transmit and receive mode, active high
12	GND	Ground	Digital ground
13	VDEC1	De-coupling	Requires de-coupling capacitor
14	VDEC1	De-coupling	Requires de-coupling capacitor
15	VDD	Supply	Supply voltage
16	GND	Ground	Digital ground
17	CLKM	Digital output	Master clock signal output to drive controller
18	GND	Ground	Digital ground
19	SCLK	Digital input	SPI clock
20	MISO	Digital output	SPI data output (master input slave output)
21	GND	Ground	Digital ground
22	MOSI	Digital input	SPI data input (master output slave input)
23	$\overline{\text{SEL}}$	Digital input	SPI select signal, active low
24	IRQ	Digital output	Interrupt request signal
25	XTAL1	Analog input	Crystal pin
26	XTAL2	Analog input	Crystal pin
27	GND	Ground	Analog ground
28	VDD	Supply	Supply voltage
29	VDEC2	De-coupling	Requires de-coupling capacitor
30	GND	Ground	Analog ground
31	GND	Ground	Analog ground
32	GND	Ground	Analog ground

Table 10-1. AT86RF230 Pin List

10.1. Pin-out Diagram

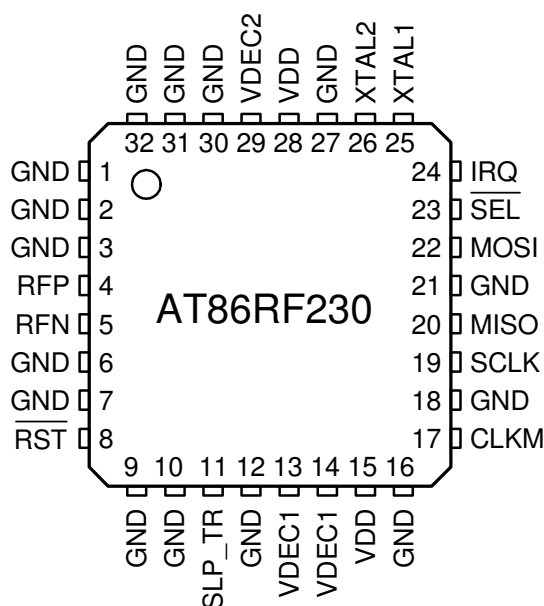

10.2. Decoupling

Correct functionality requires de-coupling of the internal power supply voltage (VDEC1/2). Capacitors of 1µF (recommended value) shall be placed as close as possible to IC pins and shall be connected to ground with the shortest possible traces. Avoid long lines. It is recommended to insert additional 100 nF capacitors as close as possible at each VDD pin to ground.

10.3. Analog Pins

Pin	Condition	Recommendation/Comment
RFP/RFN	V _{DC} = 0.9V (TX) V _{DC} = 20 mV (RX) at both pins	Blocking is required if an antenna with a DC path to ground is used. Serial capacitance must be < 30 pF.
XTAL1/XTAL2	C _{PAR} = 3 pF V _{DC} = 0.9V at both pins	Parasitic capacitance of the IC pins must be considered as additional parallel capacitance to the crystal.

Table 10-2. Comments on RF Input/Output and Crystal Pins

10.4. RF Pins

A differential RF input provides common-mode rejection to suppress the switching noise of the internal digital signal processing blocks. At the board-level, the differential RF layout ensures the receiver sensitivity by rejecting any spurious signals originating from other digital ICs such as the micro-controller.

The RF port is designed for a 100Ω differential load. A differential DC path between the RF pins is allowed. A DC path to ground or supply voltage is not allowed and requires capacitive coupling as indicated in Table 10-2.

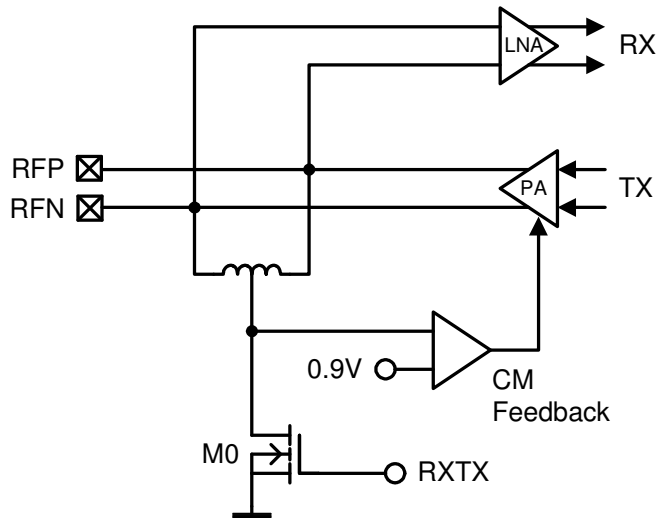

Figure 10-1. Simplified RF Front-end Schematic

A simplified schematic of the RF front end is shown in **Figure 10-1**. RF port DC values depend on the operating mode. In TRX_OFF mode, the RF pins are pulled to ground, preventing a floating voltage larger than 1.8V which is not allowed for the internal circuitry. In receive mode, the RF input provides a low-impedance path to ground when transistor M0 pulls the inductor center tap to ground. A DC voltage drop of 20 mV across the on-chip inductor can be measured at the RF pins. In transmit mode, a regulation loop provides a common-mode voltage of 0.9V. Transistor M0 is off, allowing the PA to set the common-mode voltage. The common-mode capacitance at each pin to ground is limited to < 30 pF to ensure the stability of this common-mode feedback loop.

10.5. Digital Pins

Pulling resistors are connected to all digital input pins in transceiver state P_ON. Table 10-3 summarizes the pull-up and pull-down configuration.

In all other states there is no pull-up or pull-down resistor connected to any of the digital input pins.

Pin	H = pull-up, L = pull-down
$\overline{\text{RST}}$	H
$\overline{\text{SEL}}$	H
SCLK	L
MOSI	L
SLP_TR	L

Table 10-3. Pull-up / pull-down configuration of digital input pins

11. Ordering Information

Ordering Code	Package	Voltage Range	Temperature Range
AT86RF230-ZU	QN	1.8 – 3.6V	Industrial (-40 °C to 85 °C) Lead-free/Halogen-free

Package Type	Description
QN	32QN1, 32-lead 5.0 x5.0mm Body, 0.50mm Pitch, Quad Flat No-lead Package (QFN) Sawn

Note: T&R quantity 2,500. Please contact your local Atmel sales office for more detailed ordering information and minimum quantities.

12. Soldering Information

Recommended soldering profile is specified in IPC/JEDEC J-STD-.020C.

13. Package Thermal Properties

Thermal Resistance	
Velocity [m/s]	Theta ja [K/W]
0	40.9
1	35.7
2.5	32.0



14. Package Drawing – 32QN1

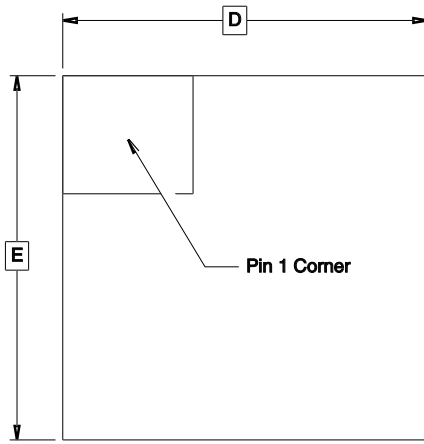

Top View

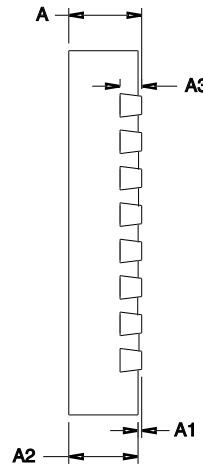

Side View

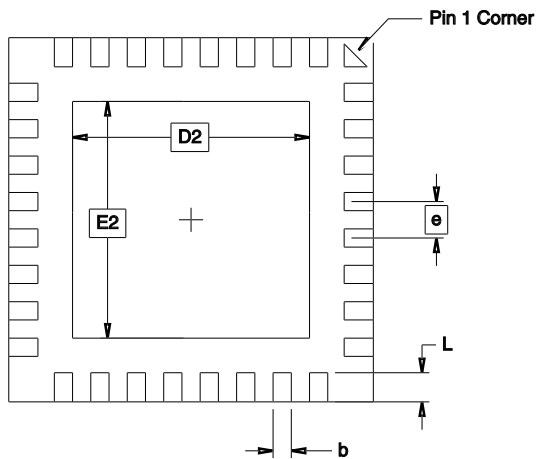

Bottom View

COMMON DIMENSIONS
(Unit of Measure = mm)

SYMBOL	MIN	NOM	MAX	NOTE
D	5.00 BSC			
E	5.00 BSC			
D2	1.25		3.25	
E2	1.25		3.25	
A	0.80	0.90	1.00	
A1	0.0	0.02	0.05	
A2	0.0	0.65	1.00	
A3	0.20 REF			
L	0.30	0.40	0.50	
e	0.50 BSC			
b	0.18	0.23	0.30	2

- Notes:
1. This drawing is for general information only. Refer to JEDEC Drawing MO-220, Variation VHHD-1, for proper dimensions, tolerances, datums, etc.
 2. Dimension b applies to metallized terminal and is measured between 0.15 mm and 0.30 mm from the terminal tip. If the terminal has the optional radius on the other end of the terminal, the dimension should not be measured in that radius area.

1/24/06



2325 Orchard Parkway
San Jose, CA 95131

TITLE

32QN1, 32-lead 5.0 x 5.0 mm Body, 0.50 mm Pitch, Quad Flat
No Lead Package (QFN) Sawn

DRAWING NO.

32QN1

REV.

A

15. References

- [1] IEEE Std 802.15.4-2003: Wireless Medium Access Control (MAC) and Physical Layer (PHY) Specifications for Low-Rate Wireless Personal Area Networks (LR-WPANs)
- [2] ANSI / ESD-STM5.1-2001: ESD Association Standard Test Method for electrostatic discharge sensitivity testing – Human Body Model (HBM)
- [3] EIA / JESD22-A115-A: Electronic Industries Association, Electrostatic Discharge Sensitivity Testing – Machine Model (MM)
- [4] ESD-STM5.3.1-1999: ESD Association Standard Test Method for electrostatic discharge sensitivity testing – Charged Device Model (CDM)

16. Revisions

Revision	Date	Description
1.0	2006-06-14	Initial release



Atmel Corporation

2325 Orchard Parkway
San Jose, CA 95131, USA
Tel: 1(408) 441-0311
Fax: 1(408) 487-2600

Regional Headquarters

Europe

Atmel Sarl
Route des Arsenaux 41
Case Postale 80
CH-1705 Fribourg
Switzerland
Tel: (41) 26-426-5555
Fax: (41) 26-426-5500

Asia

Room 1219
Chinachem Golden Plaza
77 Mody Road Tsimshatsui
East Kowloon
Hong Kong
Tel: (852) 2721-9778
Fax: (852) 2722-1369

Japan

9F, Tonetsu Shinkawa Bldg.
1-24-8 Shinkawa
Chuo-ku, Tokyo 104-0033
Japan
Tel: (81) 3-3523-3551
Fax: (81) 3-3523-7581

Atmel Operations

Memory

2325 Orchard Parkway
San Jose, CA 95131, USA
Tel: 1(408) 441-0311
Fax: 1(408) 436-4314

Microcontrollers

2325 Orchard Parkway
San Jose, CA 95131, USA
Tel: 1(408) 441-0311
Fax: 1(408) 436-4314

La Chantrerie
BP 70602
44306 Nantes Cedex 3, France
Tel: (33) 2-40-18-18-18
Fax: (33) 2-40-18-19-60

ASIC/ASSP/Smart Cards

Zone Industrielle
13106 Rousset Cedex, France
Tel: (33) 4-42-53-60-00
Fax: (33) 4-42-53-60-01

1150 East Cheyenne Mtn. Blvd.
Colorado Springs, CO 80906, USA
Tel: 1(719) 576-3300
Fax: 1(719) 540-1759

Scottish Enterprise Technology Park
Maxwell Building
East Kilbride G75 0QR, Scotland
Tel: (44) 1355-803-000
Fax: (44) 1355-242-743

RF/Automotive

Theresienstrasse 2
Postfach 3535
74025 Heilbronn, Germany
Tel: (49) 71-31-67-0
Fax: (49) 71-31-67-2340

1150 East Cheyenne Mtn. Blvd.
Colorado Springs, CO 80906, USA Tel:
1(719) 576-3300 Fax: 1(719) 540-1759

Biometrics/Imaging/Hi-Rel MPU/ High Speed Converters/RF Datacom

Avenue de Rochepleine
BP 123 38521
Saint-Egreve Cedex, France
Tel: (33) 4-76-58-30-00
Fax: (33) 4-76-58-34-80

Literature Requests

www.atmel.com/literature

Disclaimer: The information in this document is provided in connection with Atmel products. No license, express or implied, by estoppel or otherwise, to any intellectual property right is granted by this document or in connection with the sale of Atmel products. **EXCEPT AS SET FORTH IN ATMEL'S TERMS AND CONDITIONS OF SALE LOCATED ON ATMEL'S WEB SITE, ATMEL ASSUMES NO LIABILITY WHATSOEVER AND DISCLAIMS ANY EXPRESS, IMPLIED OR STATUTORY WARRANTY RELATING TO ITS PRODUCTS INCLUDING, BUT NOT LIMITED TO, THE IMPLIED WARRANTY OF MERCHANTABILITY, FITNESS FOR A PARTICULAR PURPOSE, OR NON-INFRINGEMENT. IN NO EVENT SHALL ATMEL BE LIABLE FOR ANY DIRECT, INDIRECT, CONSEQUENTIAL, PUNITIVE, SPECIAL OR INCIDENTAL DAMAGES (INCLUDING, WITHOUT LIMITATION, DAMAGES FOR LOSS OF PROFITS, BUSINESS INTERRUPTION, OR LOSS OF INFORMATION) ARISING OUT OF THE USE OR INABILITY TO USE THIS DOCUMENT, EVEN IF ATMEL HAS BEEN ADVISED OF THE POSSIBILITY OF SUCH DAMAGES.** Atmel makes no representations or warranties with respect to the accuracy or completeness of the contents of this document and reserves the right to make changes to specifications and product descriptions at any time without notice. Atmel does not make any commitment to update the information contained herein. Unless specifically provided otherwise, Atmel products are not suitable for, and shall not be used in, automotive applications. Atmel's products are not intended, authorized, or warranted for use as components in applications intended to support or sustain life.

© 2006, Atmel Corporation. All rights reserved. Atmel®, logo and combinations thereof, Everywhere You Are® and others, are registered trademarks or trademarks of Atmel Corporation or its subsidiaries. Other terms and product names may be trademarks of others.