

**Modular Crimp Head
Order No. 63811-4870**

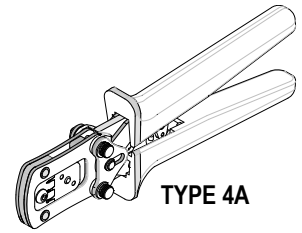

**Application Tooling
Specification Sheet**



**Hand Crimp Tool
Order No. 63811-4800**

FEATURES

- % A full cycle ratcheting hand tool ensures complete crimps
- % Ergonomically designed soft handles
- % Precisely designed crimping profiles with simple contact positioning
- % Easy handling due to outstanding force ratio
- % A-620 Class 3 compliant and RoHS compliant
- % Modular Crimp Head is removable and can be use in the Air Powered Tool Order No.63816-0100, accompanied by Air Powered Crimp Adapter (Order No. 63816-0700).
- % Can also be used in the Battery Powered Tool Order No.63816-0200 (110 V) or 63816-0250 (220 V), accompanied by Battery Powered Crimp Adapter (Order No. 63816-0600).

SCOPE

Products: 1.27mm (.050") Pitch Ulti-Mate™ Commercial Micro D, 26-28 AWG.

Terminal Series No.	Terminal Order No.			Wire Size		*Insulation Diameter		Strip Length	
	Loose Piece	*Reel		AWG	mm ²	mm	In.	mm	In.
83000	83000-0083	83000-9502	83000-9558	26	0.12	0.89-1.02	.035-.040	1.30-1.60	.051-.063
	83000-0106	83000-9503	83000-9559						
	83000-0110	83000-9547	83000-9561						
	83000-9560	83000-9550	83000-9562						
		83000-9557							
	83000-0083	83000-9502	83000-9558	28	0.08	0.50-1.00	.020-.039	1.30-1.60	.051-.063
	83000-0106	83000-9503	83000-9559						
	83000-0110	83000-9547	83000-9561						
	83000-9560	83000-9550	83000-9562						
		83000-9557							

* Customer to cut off terminal from reel: 0.15mm (.006") maximum Cut-Off Tab.
 *Insulation diameters below 0.63mm (.029") may not provide A-620 Class 3 compliant insulation crimps.
 Customer to determine suitability for these applications.

DEFINITION OF TERMS

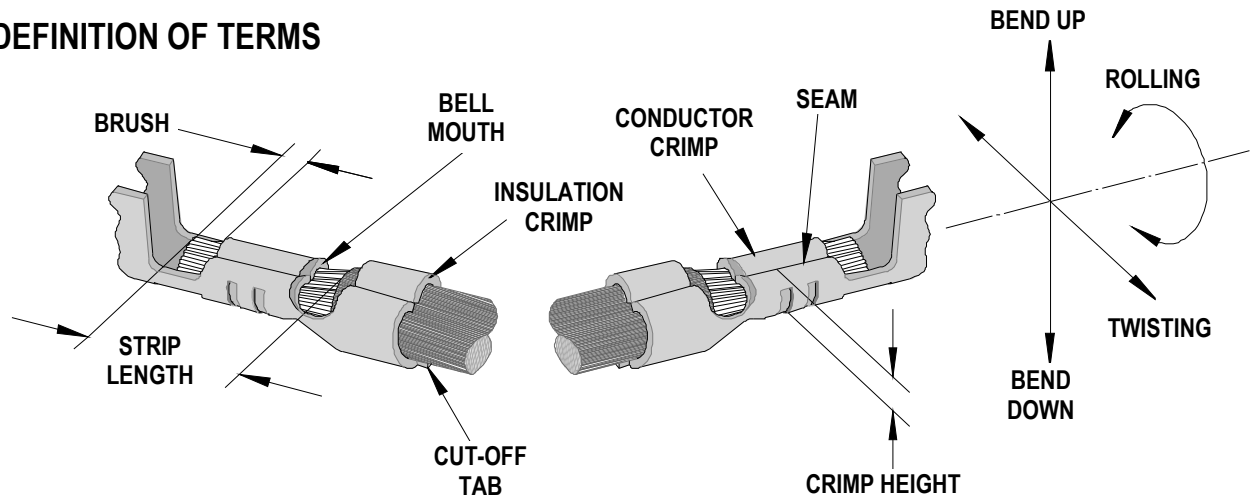

The above terminal drawing is a generic terminal representation. It is not an image of a terminal listed in the scope.

CRIMP SPECIFICATION

After crimping, the conductor profile should measure the following.

Terminal Order No.	Wire Size		Tool Wire Insulation Diameter		Crimp Conductor (REF)			
					Height		Width	
	AWG	mm ²	mm	In.	mm	In.	mm	In.
83000-0083, 83000-9502 83000-9503, 83000-9550	26	0.12	0.89-1.02	.035-.040	0.54-0.58	.021-.023	0.81	.031
	28	0.08	0.76-1.00	.030-.039	0.41-0.46	.016-.018	0.81	.031
	28	0.08	0.50-0.75	.020-.029	0.41-0.46	.016-.018	0.81	.031
83000-0106 83000-9547 83000-9557	26	0.12	0.89-1.02	.035-.040	0.54-0.58	.021-.023	0.81	.031
	28	0.08	0.76-1.00	.030-.039	0.41-0.46	.016-.018	0.81	.031
	28	0.08	0.50-0.75	.020-.029	0.41-0.46	.016-.018	0.81	.031
83000-0110 83000-9558 83000-9559	26	0.12	0.89-1.02	.035-.040	0.54-0.58	.021-.023	0.81	.031
	28	0.08	0.76-1.00	.030-.039	0.41-0.46	.016-.018	0.81	.031
	28	0.08	0.50-0.75	.020-.029	0.41-0.46	.016-.018	0.81	.031
83000-9560 83000-9561 83000-9562	26	0.12	0.89-1.02	.035-.040	0.54-0.58	.021-.023	0.81	.031
	28	0.08	0.76-1.00	.030-.039	0.41-0.46	.016-.018	0.81	.031
	28	0.08	0.50-0.75	.020-.029	0.41-0.46	.016-.018	0.81	.031

Terminal Order No.	Wire Size		Pull Force Minimum		Profile			Locator Color
					26 AWG	28 AWG Large Insulation	28 AWG Small Insulation	
	AWG	mm ²	N	Lb.	A	B	C	
83000-0083, 83000-9502 83000-9503, 83000-9550	26	0.12	13.4	3.00	X			Blue
	28	0.08	9.8	2.20		X		
	28	0.08	9.8	2.20			X	
83000-0106 83000-9547 83000-9557	26	0.12	13.4	3.00	X			Red
	28	0.08	9.8	2.20		X		
	28	0.08	9.8	2.20			X	
83000-0110 83000-9558 83000-9559	26	0.12	13.4	3.00	X			Yellow
	28	0.08	9.8	2.20		X		
	28	0.08	9.8	2.20			X	
83000-9560 83000-9561 83000-9562	26	0.12	13.4	3.00	X			Yellow
	28	0.08	9.8	2.20		X		
	28	0.08	9.8	2.20			X	

T Tool Qualification Notes:

1. Pull Force should be measured with no influence from the insulation crimp.
2. The above specifications are guidelines to an optimum crimp.

OPERATION

Open the tool by squeezing the handles together, at the end of the closing stroke, the ratchet mechanism will release the handles, and the hand tool will spring open.

Crimping Terminals

1. With the hand tool in the open position, pivot the terminal locator open. See Figure 1.
2. Insert the terminal fully into the correct profile until the terminal is fully seated and stops.
3. Gently pivot the locator closed.
4. Slide the pre-stripped wire into the insulation stop. See Figure 2. The wire strands pass thru the insulation stop slot, while the end of the insulation touches the stop. Be sure to hold the wire in place until the terminal is fully crimped. See Figure 3.
5. Close the tool until the ratchet releases.
6. Carefully remove the crimped terminal.

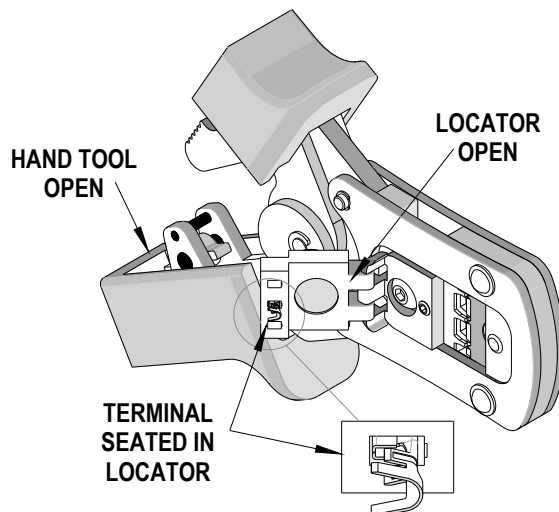

Figure 1

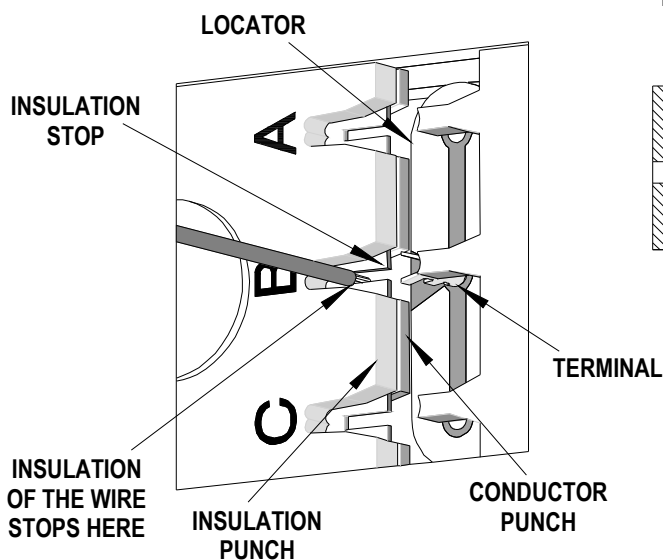

Figure 2

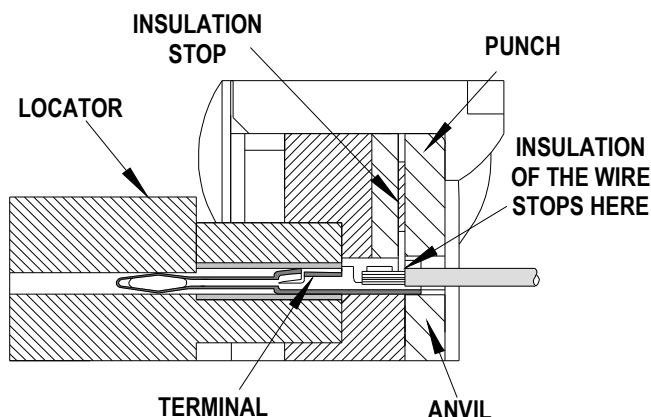

Figure 3

Note: The tamper proof ratchet action will not release the tool until it has been fully closed.

Note: To maintain good brush control and a consistent bell mouth the crimping instructions must be followed.

Terminal Locator Replacement/Change Over

This section describes the procedure for changing locators.

Removal

1. With the tool in the open position, pivot the terminal locator outward.
2. Remove the M4 BHCS. See Figure 4.

Installation

1. Place the proper locator, (See Chart on page 2), on the hand tool. Install the M4 BHCS. See Figure 4.
2. Tighten the screw enough to hold the locator. Make sure the locator can still float freely with hand pressure.
3. Insert the proper terminal fully into the correct profile slot until the terminal is fully seated and stops. Then gently pivot the locator closed.
4. With hand pressure, slowly slide the locator to the correct position. See Figure 5.
5. Gently pivot the locator open without disturbing the location.
6. Hold the locator firmly in place and slowly tighten the M4 BHCS.

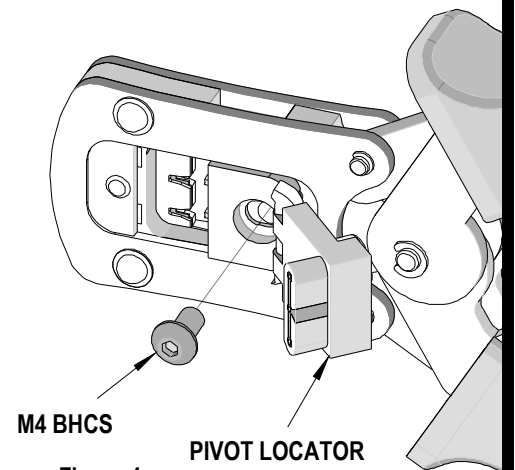

Figure 4

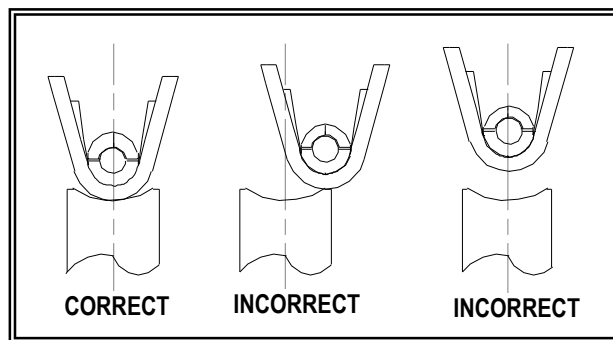

Figure 5

Maintenance

It is recommended that each operator of the tool be made aware of, and responsible for, the following maintenance steps:

1. Remove dust, moisture, and other contaminants with a clean brush, or soft, lint free cloth.
2. Do not use any abrasive materials that could damage the tool.
3. Make certain all pins; pivot points and bearing surfaces are protected with a thin coat of high quality machine oil. Do not oil excessively. The tool was engineered for durability but like any other equipment it needs cleaning and lubrication for a maximum service life of trouble free crimping. Light oil (such as 30 weight automotive oil) used at the oil points, every 5,000 crimps or 3 months, will significantly enhance the tool life.
4. Wipe excess oil from hand tool, particularly from crimping area. Oil transferred from the crimping area onto certain terminations may affect the electrical characteristics of an application.
5. When tool is not in use, keep the handles closed to prevent objects from becoming lodged in the crimping dies, and store the tool in a clean, dry area.

Miscrimps or Jams

Should this tool ever become stuck or jammed in a partially closed position, **Do Not force the handles open or closed.** The tool will open easily by lifting the ratchet release lever. See Figure 9.

Warranty

This tool is for electrical terminal crimping purposes only. This tool is made of the best quality materials. All vital components are long life tested. All tools are warranted to be free of manufacturing defects for a period of 30 days. Should such a defect occur, we will repair or exchange the tool free of charge. This repair or exchange will not be applicable to altered, misused, or damaged tools. This tool is designed for hand use only. Any clamping, fixturing, or use of handle extensions voids this warranty.

CAUTION: Repetitive use of this tool should be avoided.

CAUTIONS:

1. Manually powered hand tools are intended for low volume or field repair. This tool is **NOT** intended for production use. Repetitive use of this tool should be avoided.
2. Insulated rubber handles are not protection against electrical shock.
3. Wear eye protection at all times.
4. Use only the Molex terminals specified for crimping with this tool.

Notes:

1. This tool should only be used for the terminals and wire gauges specified on this sheet.
2. This tool is not adjustable for crimp height; however crimp force is adjustable (See instructions above). Variations in tools, terminals, wire stranding, and insulation types may affect crimp height.
3. This tool is intended for standard conductor sizes. It may not give a good insulation crimp support for all insulation sizes.
4. Molex does not repair hand tools (see warranty above). The replacement parts listed are the only parts available for repair. If the handles or crimp tooling is damaged or worn, a new tool must be purchased.
5. Pull force should be used as the final criteria for an acceptable crimp. Pull force is measured with no influence from the insulation crimp. The insulation should be stripped long (1/2 in.) so the insulation grips on the terminal do not grip the wire insulation or the conductor. Refer to Molex Quality Crimping Handbook 63800-0029 for additional information on crimping and crimp testing.
6. Molex does not certify crimp hand tools.

CAUTION: Molex crimp specifications are valid only when used with Molex terminals and tooling.

Applications for the Modular Crimp Head

WARNING: NEVER operate, service, install, or adjust this Modular Crimp Head without proper instruction and without first reading and understanding the instructions in the proper Manual or Specification Sheet. See Chart below for the correct Manual or Specification Sheet.

WARNING: NEVER install tooling or service this tool while it is into any power source. Disconnect the power by unplugging or turn off the Actuator from its power source.

CAUTION: Keep fingers away from the crimping area when operating this tool. It may cause severe injury.

CAUTION: Wear safety glasses when operating or serving this tool.

The chart below shows all applications for this Modular Crimp Head.

Modular Crimp Head Order No.	Tool Order no.	Tool Description	Adapter Order No.	Adapter Description	Figure No.
63811-4870	63816-0000	Hand Crimp Frame (Short)	N/A	N/A	6
	63816-0050	Hand Crimp Frame (Long)	N/A	N/A	6
	63816-0200	Battery Power Tool (110 V)	63816-0600	Battery Power Crimp Adapter	7
	63816-0250	Battery Power Tool (220 V)	63816-0600	Battery Power Crimp Adapter	7
	63816-0100	Air Power Tool	63816-0700	Air Power Crimp Adapter	8

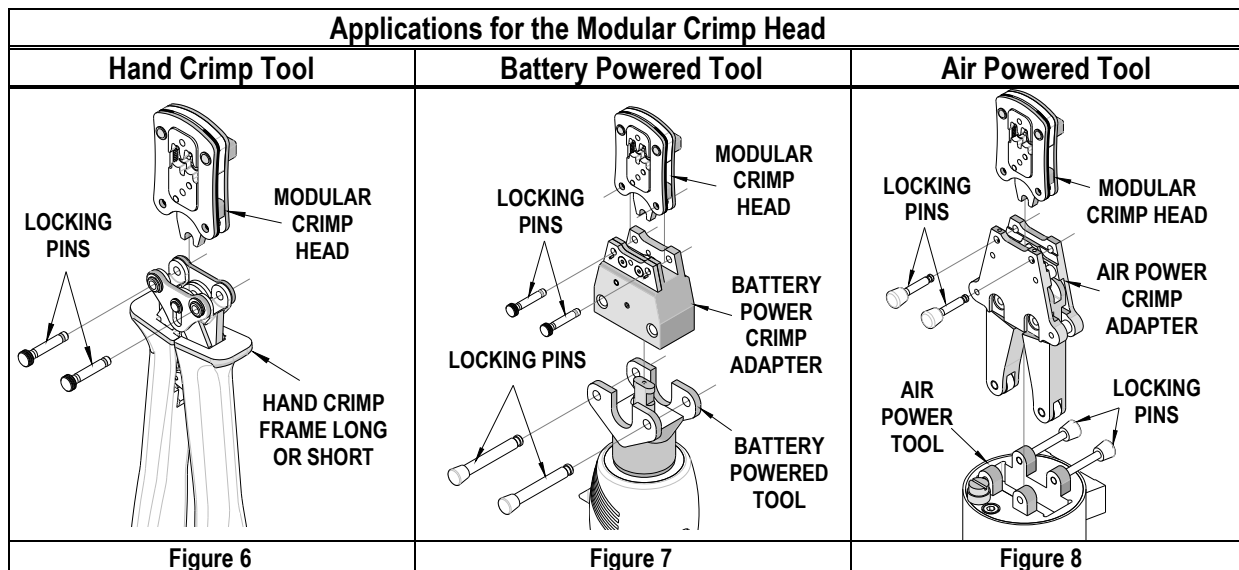

PARTS LIST

Hand Crimp Tool 63811-4800			
Item	Order Number	Description	Quantity
1	63811-4870	Modular Crimp Head	1
2	63816-0000	Hand Crimp Frame (Short)	1
3	63811-4875	Locator-Blue	1
4	63811-4876	Locator-Red	1
5	63811-4877	Locator-Yellow	1
6	63816-0001	Locking Pin	2
7	63600-0525	Handle Spring	1
8	63600-0520	Crimping Spring	2

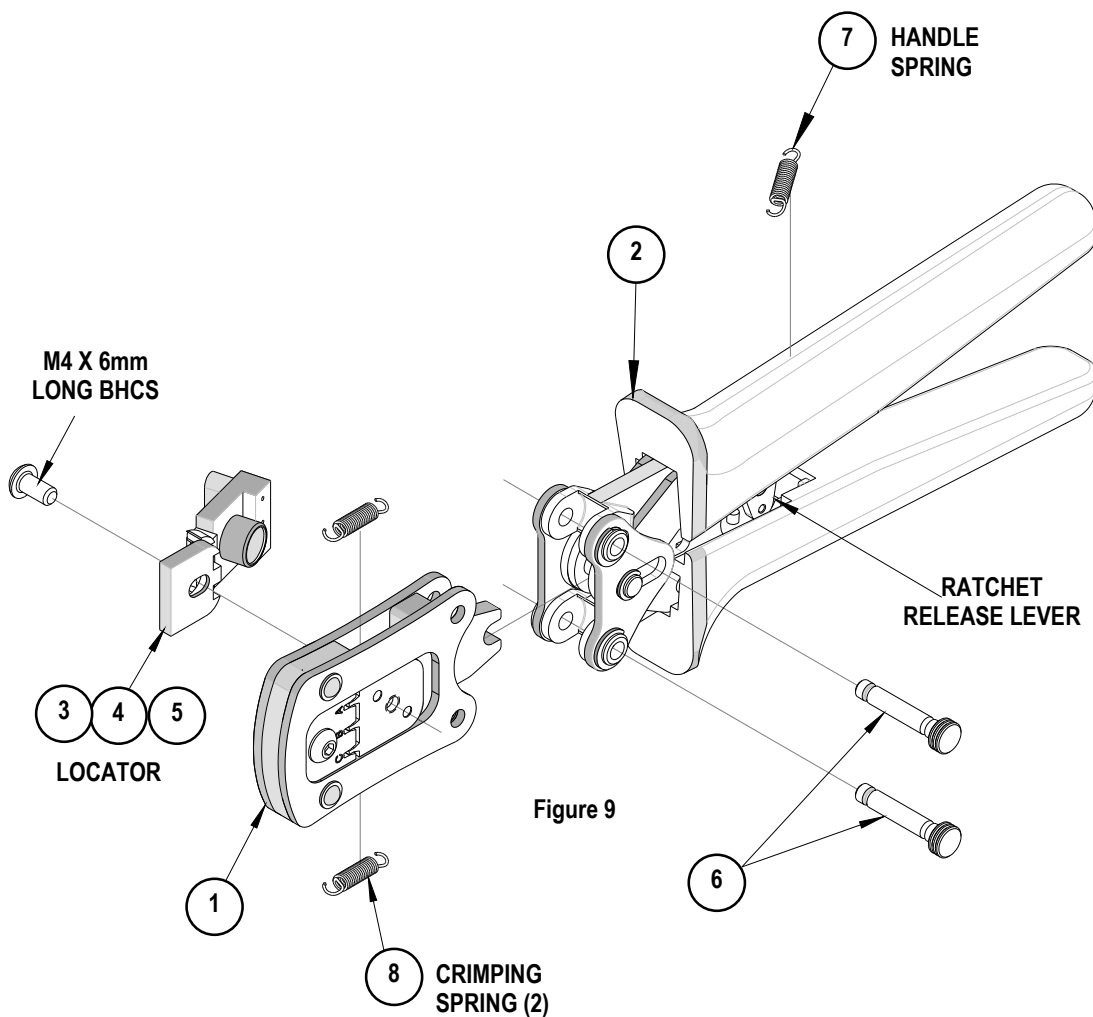

<http://www.molex.com>