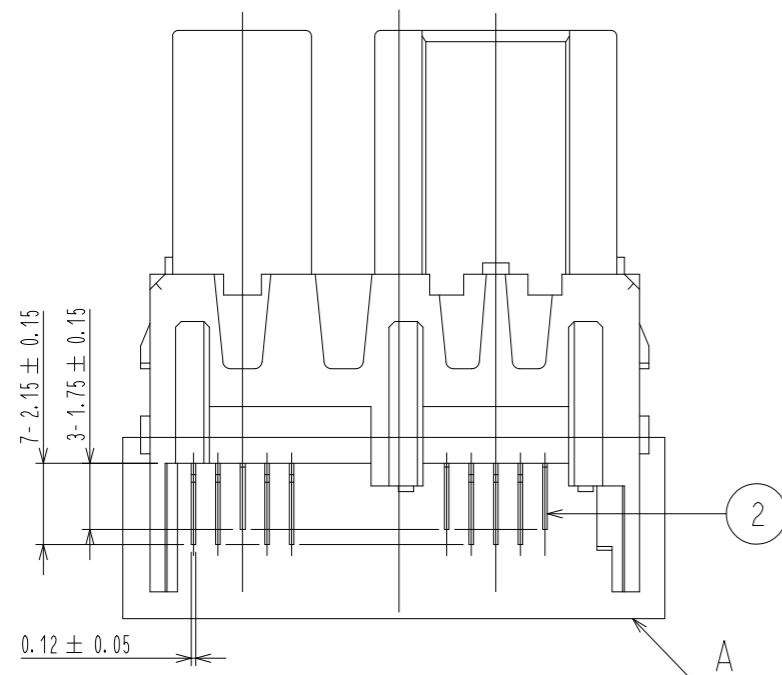
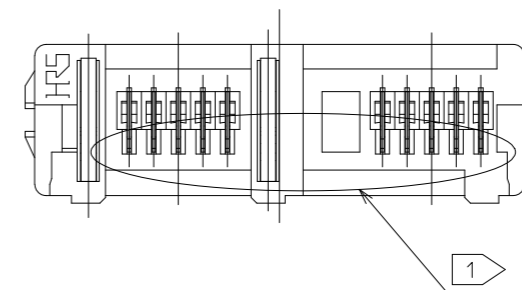
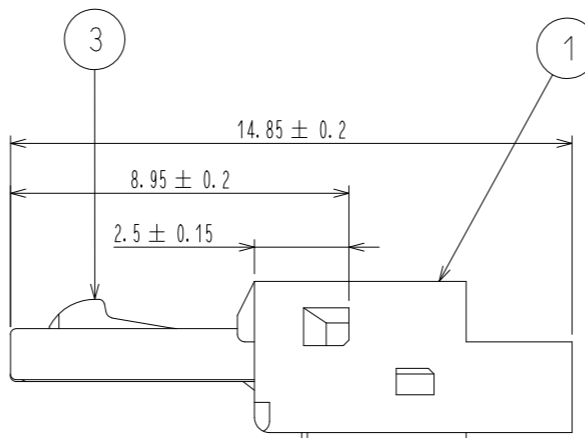
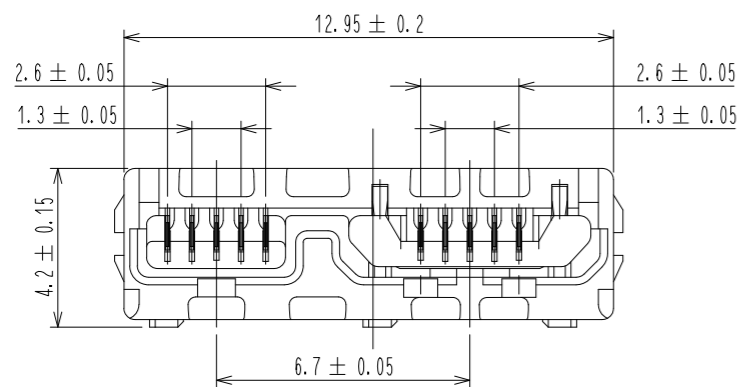
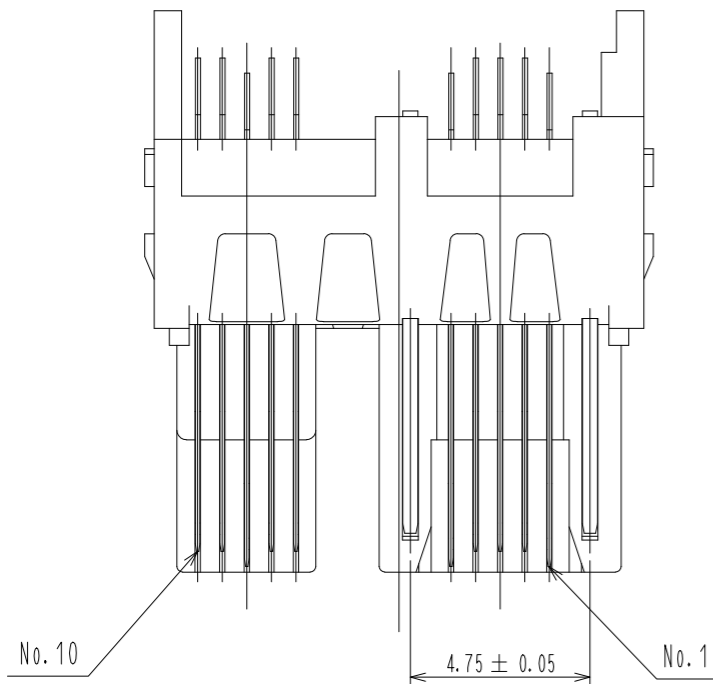
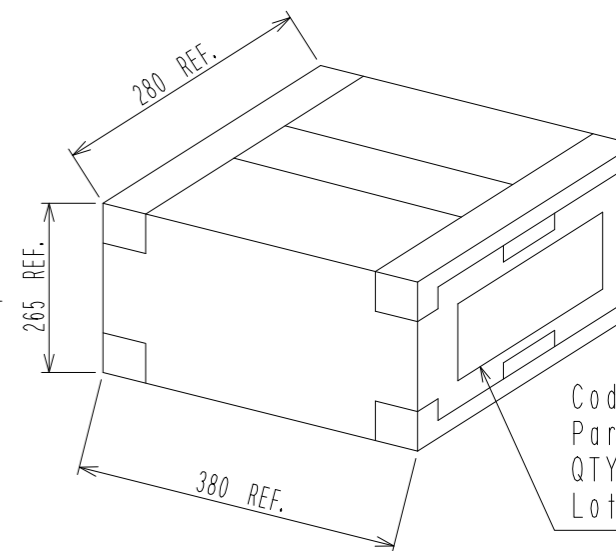
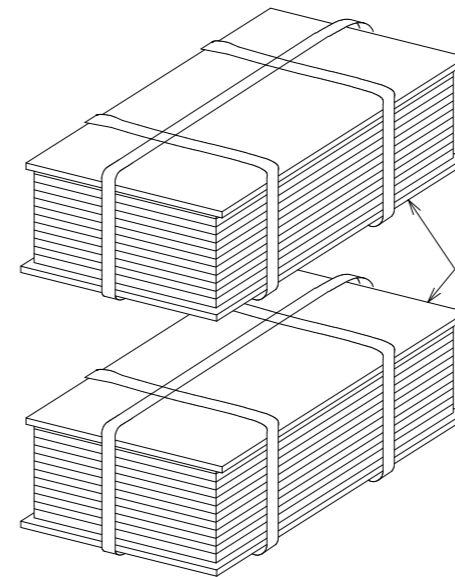
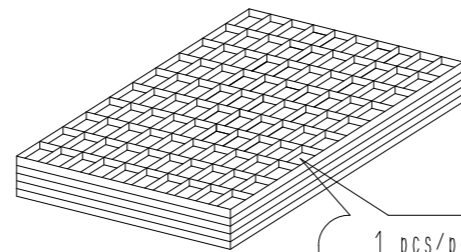

Fig-1 PACKING SPECIFICATION -IN THE CASE OF 2000 pcs-(FREE)

2. BIND THE TRAYS WITH CONNECTOR UNITS AS SHOWN BELOW.

3. SET THE TRAYS INSIDE THE CARDBOARD BOX.

1. PLACE THE CONNECTOR UNIT INTO THE TRAY.
(100 pcs per tray)



A. Location

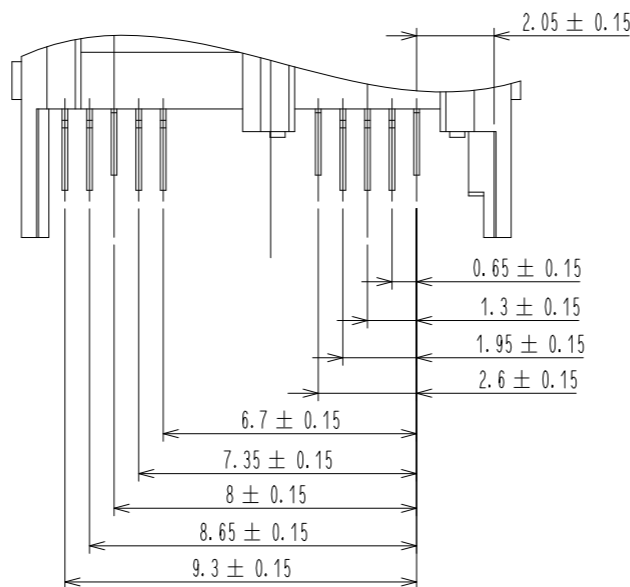

NOTES 1 CO-PLANARITY IS WITHIN 0.1mm

2. REFER TO ETAD-E2909 FOR CABLE ASSEMBLY PROCEDURES.

2	COPPER ALLOY	CONTACT AREA:GOLD PLATING 0.75μm min MOUNTING AREA:TIN PLATING 1μm min UNDER PLATING:NICKEL PLATING 2μm min	3	STAINLESS STEEL			
1	LCP	UL94V-0 , BLACK					
NO.	MATERIAL	FINISH . REMARKS	NO.	MATERIAL	FINISH . REMARKS		
UNITS mm		SCALE 5 : 1	COUNT	DESCRIPTION OF REVISIONS	DESIGNED	CHECKED	DATE
		HIROSE ELECTRIC CO., LTD.	APPROVED : A0. SUZUKI	10.08.07	DRAWING NO. EDC3-127029-00		
			CHECKED : KN. ICHIKAWA	10.08.07	PART NO. ZX360-B-10S-UNIT		
			DESIGNED : TU. TANIGUCHI	10.08.07	CODE NO. CL242-0501-4-00		
			DRAWN : TU. TANIGUCHI	10.08.07	1/3		

Fig-2. CONNECTOR MOUNTED ON PCB

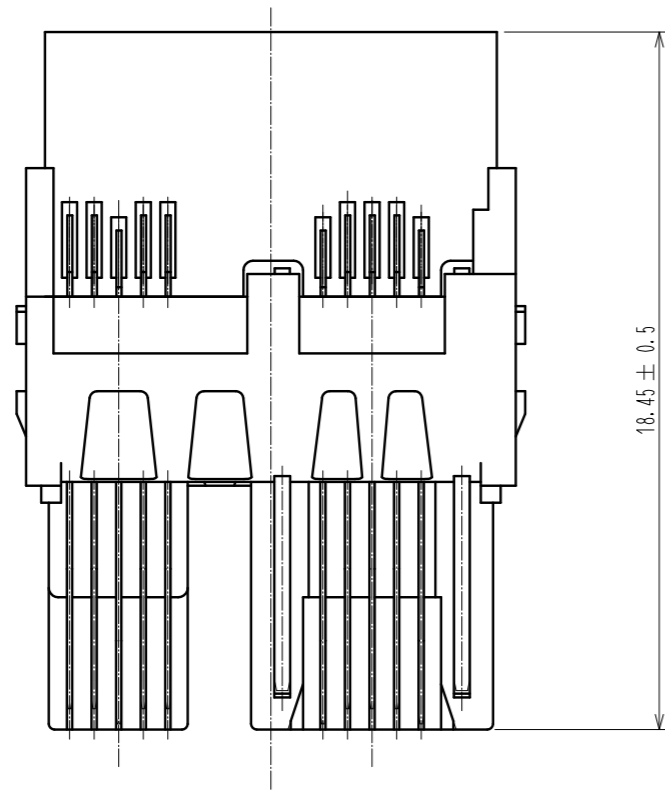

PCB LAYOUT FOR REFERENCE

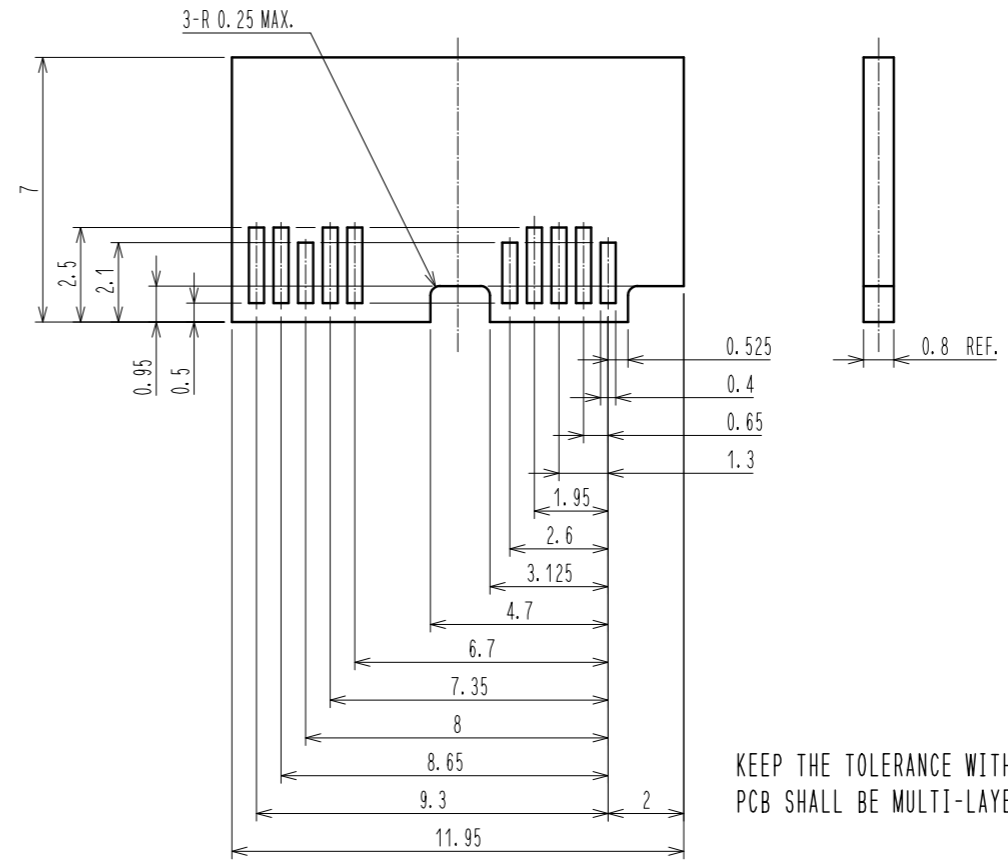

KEEP THE TOLERANCE WITHIN MAX±0.05
PCB SHALL BE MULTI-LAYER PCB INCLUDING FULL GROUND LAYER.

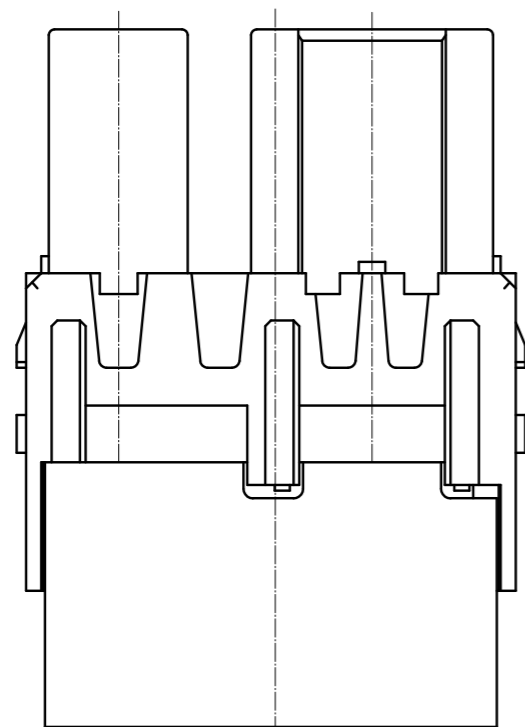
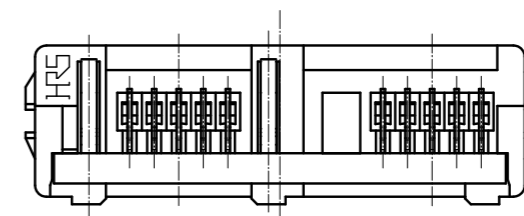
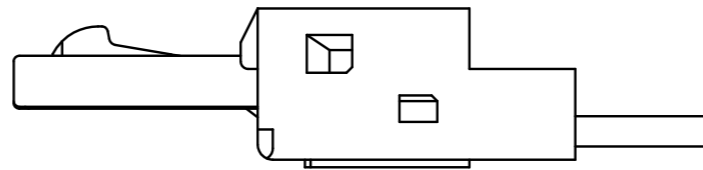
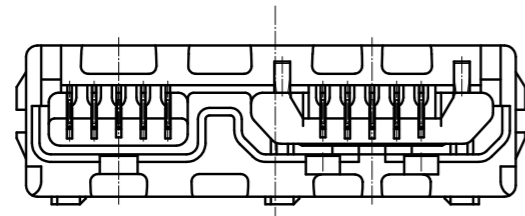

HRS	DRAWING NO.	EDC3-127029-00	2/3
	PART NO.	ZX360-B-10S-UNIT	
	CODE NO.	CL242-0501-4-00	

Fig-3 SHIELDING-PLATE ASSEMBLY

OVER-MOLDING (REFERENCE) (FREE)

ZX360-B-SLDA(SOLD SEPARATELY)

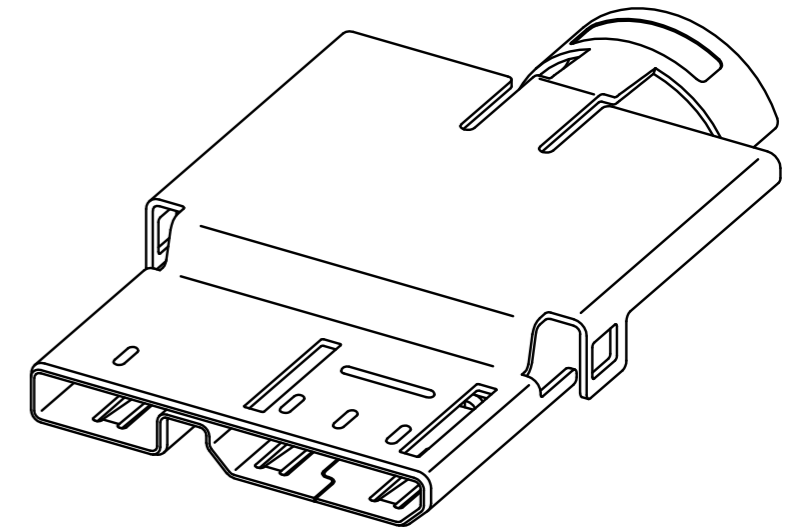
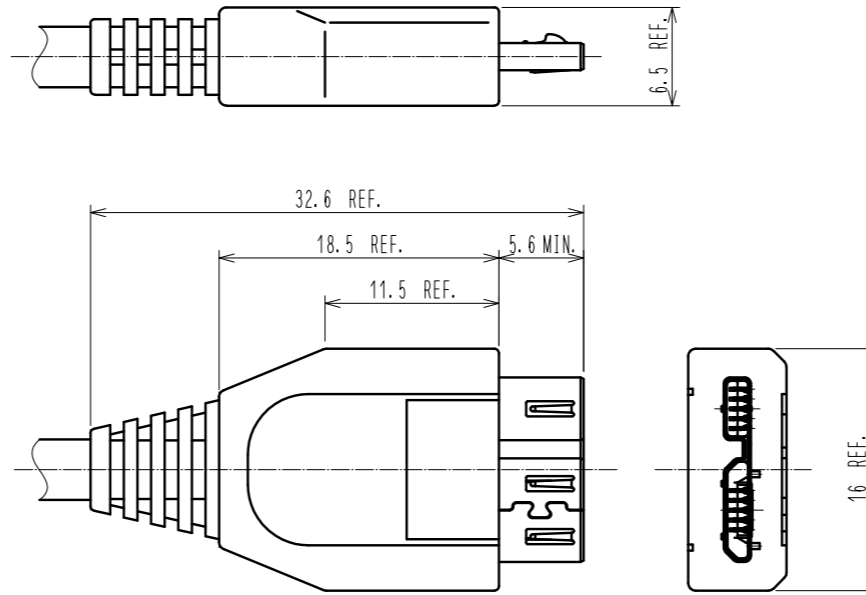
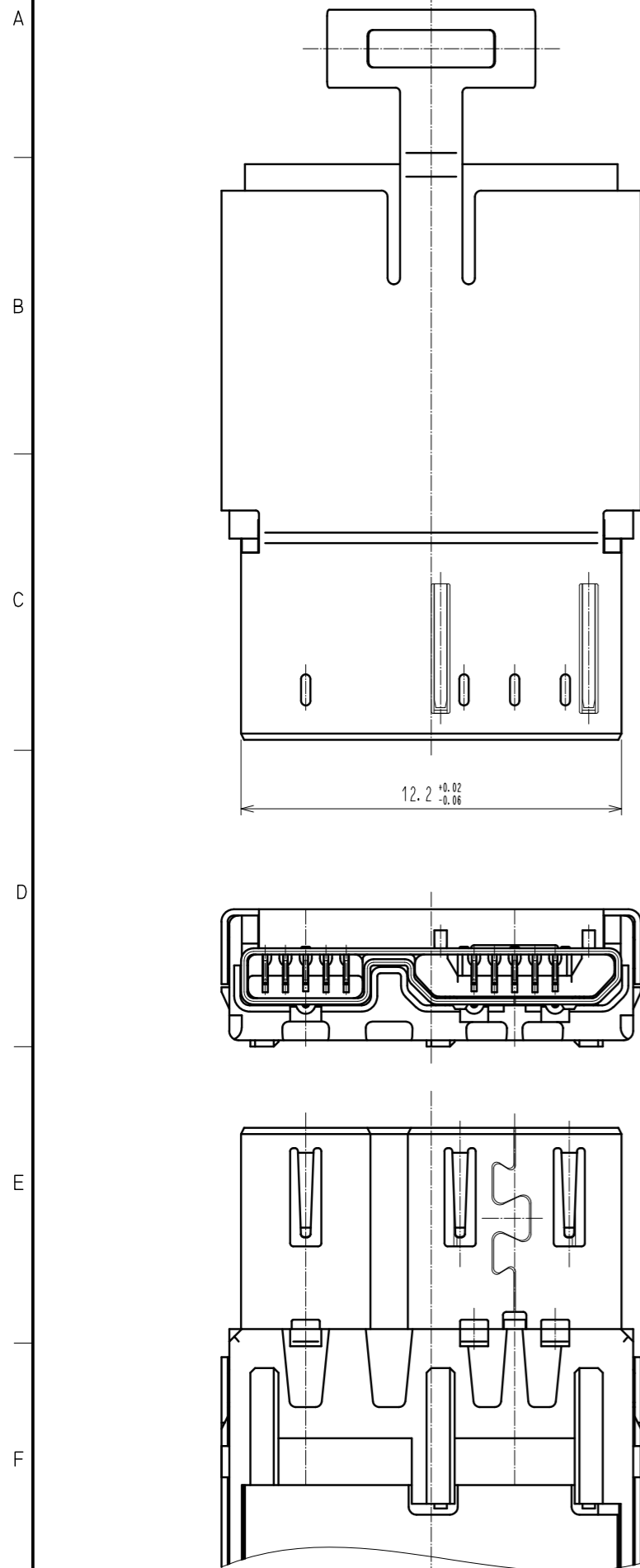
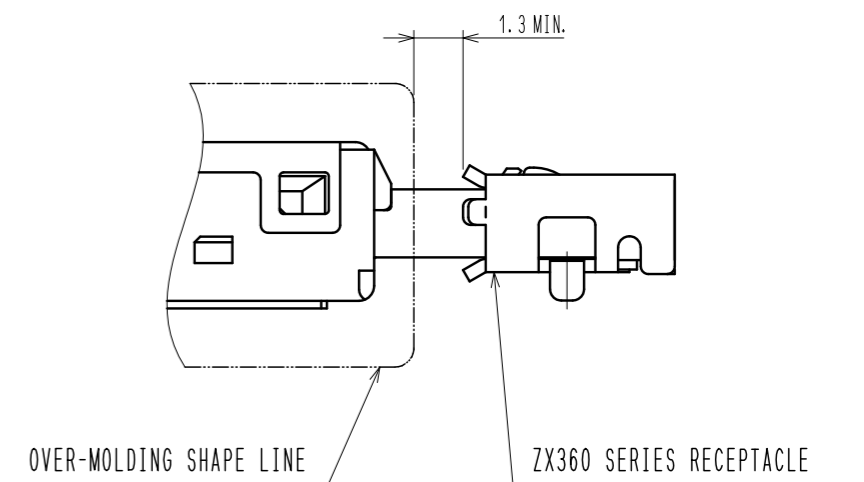
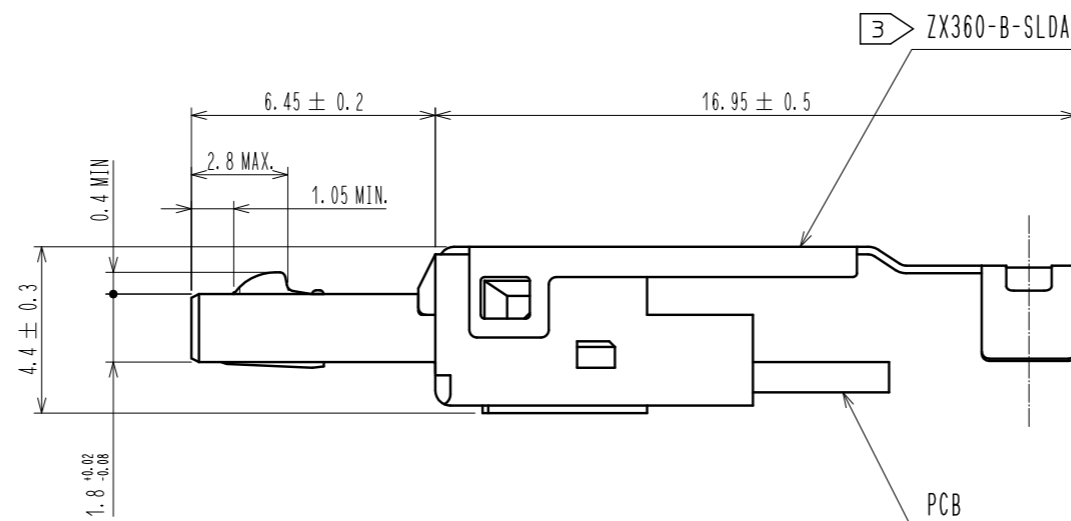

Fig-4 MATED WITH CORRESPONDING PLUG



NOTES ③ THIS COMPONENT IS ALWAYS USED WITH SEPARATELY AVAILABLE ZX360-B-SLDA

HRS	DRAWING NO.	EDC3-127029-00
	PART NO.	ZX360-B-10S-UNIT
	CODE NO.	CL242-0501-4-00
		△ 3/3