

Low Phase Noise PLL Clock Multiplier

FEATURES

- Low phase noise XO
- Input from crystal or clock at 10-27MHz.
- Integrated crystal load capacitor: no external load capacitor required.
- Output clocks up to 160MHz.
- Low phase noise (-125dBc/Hz @ 1kHz).
- Output Enable function.
- Low jitter (RMS): 7.2ps (period), 11.2ps (accum.)
- Advanced low power sub-micron CMOS process.
- 3.3V operation.
- Available in 16-Pin SOIC or TSSOP.

PIN CONFIGURATION

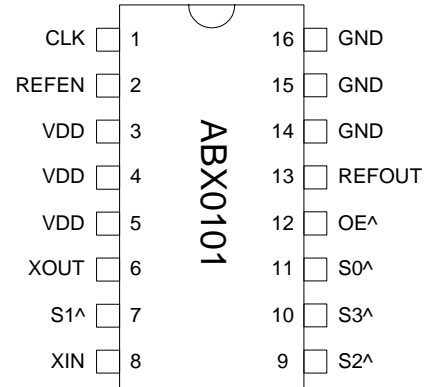

DESCRIPTION

The ABX0101 is a low cost, high performance and low phase noise clock synthesizer. Using Abracon's proprietary analog and digital Phase Locked Loop techniques, this IC can produce up to a 160MHz output.

Note: ^ denotes internal pull up.

BLOCK DIAGRAM

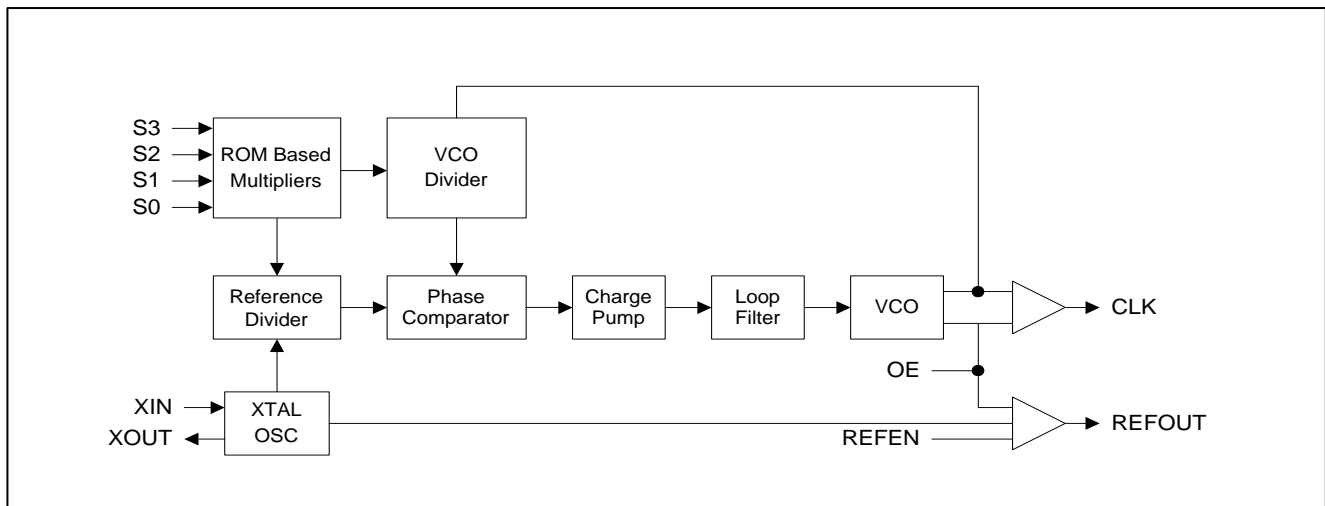

Low Phase Noise PLL Clock Multiplier

PIN DESCRIPTIONS

Name	Number	Type	Description
CLK	1	O	Clock output. Equals the input frequency times selected multiplier.
REFEN	2	I	Reference clock enable. When Low, it disables REFOUT. When High, it enables REFOUT.
VDD	3,4,5	P	Power Supply.
XOUT	6	O	Crystal output.
S1	7	I	Multiplier Select Pin 1. Determines CLK output. Has internal pull-up.
XIN	8	I	Crystal input to be connected to 10-27MHz fundamental parallel mode crystal ($C_L=15pF$). On chip load capacitors: No external capacitor required.
S2	9	I	Multiplier Select Pin 2. Determines CLK output. Has internal pull-up.
S3	10	I	Multiplier Select Pin 3. Determines CLK output. Has internal pull-up.
S0	11	I	Multiplier Select Pin 0. Determines CLK output. Has internal pull-up.
OE	12	I	Output Enable. Tri-state CLK and REFOUT when low. Has internal pull-up.
REFOUT	13	O	Buffered crystal oscillator clock output. Controlled by REFEN.
GND	14,15,16	P	Ground.

MULTIPLIER SELECT TABLE

S3	S2	S1	S0	CLK
0	0	0	0	Test
0	0	0	1	Input x 11
0	0	1	0	Input x 1
0	0	1	1	Input x 3
0	1	0	0	Input x 4
0	1	0	1	Input x 5
0	1	1	0	Input x 6
0	1	1	1	Input x 8
1	0	0	0	Input x 7
1	0	1	0	Input x 2
1	0	1	1	Input x 9
1	1	0	0	Input x 8
1	1	0	1	Input x 10
1	1	1	0	Input x 12
1	1	1	1	Input x 16

Low Phase Noise PLL Clock Multiplier

ELECTRICAL SPECIFICATIONS

1. Absolute Maximum Ratings

PARAMETERS	SYMBOL	MIN.	MAX.	UNITS
Supply Voltage	V_{DD}		4.6	V
Input Voltage, dc	V_I	-0.5	$V_{DD}+0.5$	V
Output Voltage, dc	V_O	-0.5	$V_{DD}+0.5$	V
Storage Temperature	T_S	-65	150	°C
Ambient Operating Temperature*	T_A	-40	85	°C
Junction Temperature	T_J		125	°C
Lead Temperature (soldering, 10s)			260	°C
ESD Protection, Human Body Model			2	kV

Exposure of the device under conditions beyond the limits specified by Maximum Ratings for extended periods may cause permanent damage to the device and affect product reliability. These conditions represent a stress rating only, and functional operations of the device at these or any other conditions above the operational limits noted in this specification is not implied.

* Note: Operating Temperature is guaranteed by design for all parts (COMMERCIAL and INDUSTRIAL), but tested for COMMERCIAL grade only.

2. AC Specifications

PARAMETERS	CONDITIONS	MIN.	TYP.	MAX.	UNITS
Input Frequency	Fundamental parallel resonance	10		27	MHz
Output Frequency	At 3.3V			160	MHz
Output Rise Time	0.8V to 2.0V with no load			1.5	ns
Output Fall Time	2.0V to 0.8V with no load			1.5	ns
Duty Cycle	@ 50% V_{DD}	45	50	55	%

3. DC Specifications

PARAMETERS	SYMBOL	CONDITIONS	MIN.	TYP.	MAX.	UNITS
Operating Voltage	V_{DD}		2.97		3.63	V
Input High Voltage	V_{IH}		2			V
Input Low Voltage	V_{IL}				0.8	V
Input High Voltage	V_{IH}	For XIN pin	$(V_{DD}/2) + 1$	$V_{DD}/2$		V
Input Low Voltage	V_{IL}	For XIN pin		$V_{DD}/2$	$(V_{DD}/2) - 1$	V
Output High Voltage	V_{OH}	$I_{OH} = -25mA$	2.4			V
Output Low Voltage	V_{OL}	$I_{OL} = 25mA$			0.4	V
Output High Voltage At CMOS Level	V_{OH}	$I_{OH} = -8mA$	$V_{DD}-0.4$			V
Operating Supply Current	I_{DD}	No Load		35		mA
Short-circuit Current	I_S			±50		mA
Input Capacitance	C_{IN}	OE, Select Pins		5		pF

Low Phase Noise PLL Clock Multiplier

4. Crystal Specifications

PARAMETERS	SYMBOL	CONDITIONS	MIN.	TYP.	MAX.	UNITS
Crystal Resonator Frequency	F_{XIN}	Parallel Fundamental Mode	10		27	MHz
Crystal Loading Capacitance Rating	$C_L (xtal)$			15		pF

5. Jitter Specifications

PARAMETERS	CONDITIONS	MIN.	TYP.	MAX.	UNITS
Max. Absolute Jitter, peak-to-peak	Short term		± 100		ps
Max. Jitter, cycle to cycle				60	ps
Phase Noise, relative to carrier, 125Mhz(x5)	100 Hz offset		105		dBc/Hz
Phase Noise, relative to carrier, 125Mhz(x5)	1kHz offset		125		dBc/Hz
Phase Noise, relative to carrier, 125Mhz(x5)	10kHz offset		130		dBc/Hz
Phase Noise, relative to carrier, 125Mhz(x5)	100kHz offset		125		dBc/Hz

Low Phase Noise PLL Clock Multiplier

PACKAGE INFORMATION

16 PIN Narrow SOIC, TSSOP (mm)

Symbol	SOIC		TSSOP	
	Min.	Max.	Min.	Max.
A	1.35	1.75	-	1.20
A1	0.10	0.25	0.05	0.15
B	0.33	0.51	0.19	0.30
C	0.19	0.25	0.09	0.20
D	9.80	10.00	4.90	5.10
E	3.80	4.00	4.30	4.50
H	5.80	6.20	6.40 BSC	
L	0.40	1.27	0.45	0.75
e	1.27 BSC		0.65 BSC	

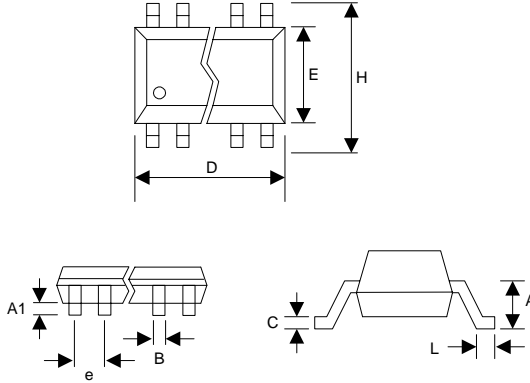

ORDERING INFORMATION

For part ordering, please contact our Sales Department:
 30332 Esperanza., Rancho Santa Margarita, Ca 92688
 Ph: 949-546-8000 Fax: 949-546-8001

PART NUMBER

The order number for this device is a combination of the following:
 Device number, Package type and Operating temperature range

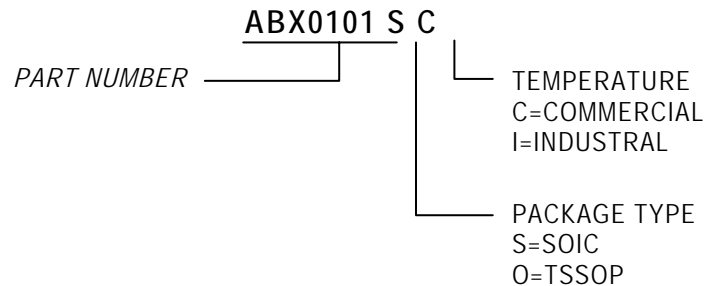

Order Number	Marking	Package Option
ABX0101OC	ABX0101OC	16-Pin TSSOP (Tube)
ABX0101OC-T	ABX0101OC	16-Pin TSSOP (Tape & Reel)
ABX0101SC	ABX0101SC	16-Pin SOIC (Tube)
ABX0101SC-T	ABX0101SC	16-Pin SOIC (Tape & Reel)

Abracon Corporation, reserves the right to make changes in its products or specifications, or both at any time without notice. The information furnished by Abracon is believed to be accurate and reliable. However, Abracon makes no guarantee or warranty concerning the accuracy of said information and shall not be responsible for any loss or damage of whatever nature resulting from the use of, or reliance upon this product.

LIFE SUPPORT POLICY: Abracon's products are not authorized for use as critical components in life support devices or systems without the express written approval of the President of Abracon Corporation.