

CIRCUIT DIAGRAM

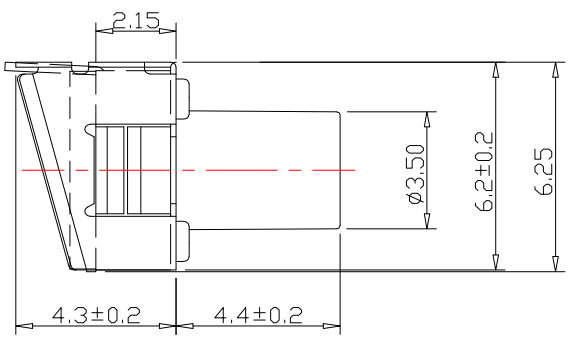

REFERENCE DRAWING

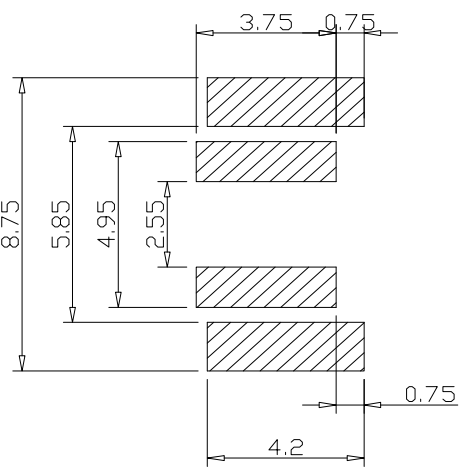

P.C.B LAND DIMENSION

Operating Pressure: 180gf ±30gf
 Operating Stroke: 0.35mm±0.15mm
 Function: (ON)-OFF
 Rating (Resistive load): 50mA 12V (DC)
 Contact Resistance: 100mΩ Max
 Insulation Resistance: 100MΩ Min
 Dielectric Strength: 250V/AC 1 minute
 Electrical life: 50,000 cycles(5V 5mA, 1Ω Max)
 Operating Temperature: -20°C~70°C
 Relative Air Humidity: 45%~85%



公差 TOLERANCES		.X±0.5 .XX±0.3		角度 ANGLE ±1°		单位		DIMENSION UNIT		mm.	
版本 VERSION		A1		比例尺 SCALE		1:1		日期 DATE		2021.09.11	
核准 APPROVED BY				核对 CHECKED BY				绘图 DRAWN BY		孙成	
品名 TITLE		THDM03-BW1-B		图号 DRAWING NO		1080100					
变更说明 CHANGE DESCRIPTION		更新规格参数		日期 DATE		2021.09.11		ECON NO.			
版本 VER		A 1		日期 DATE		2021.09.11		ECON NO.			