



REV.	ECN NO.	REVISED	DATE

NOTE:

1.MATERIAL:

- a.HOUSING:PPA
- b.CONTACT:PHOSPHOR BRONZE  
(SURFACE PLATING: Au1U")

SEE ORDERING INFORMATION

2.ELECTRIC:

- a.CONTACT RESISTANCE: 30 MILLIOHMS MAX
- b.INSULATION RESISTANCE: 100 MEGA OHMS MIN
- c.DIELECTNIC VOLTAGE: 500V AC ONE SEC LEVEL
- d.OPERATING TEMPERATURE: -25°C~ +85°C

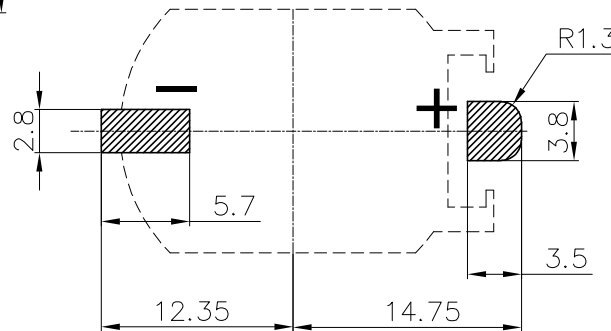
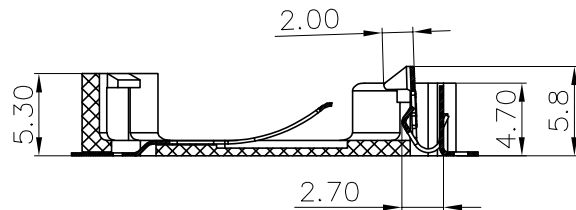
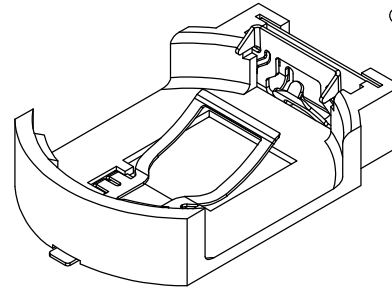
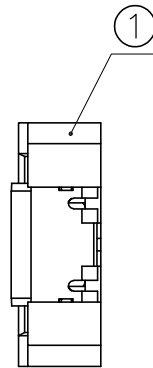
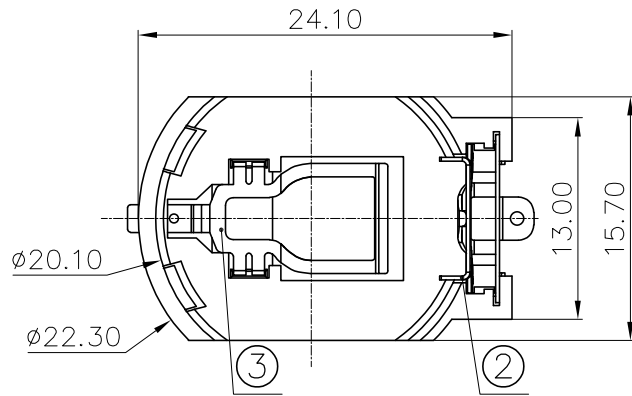

PCB Layout Diagram  
Top View

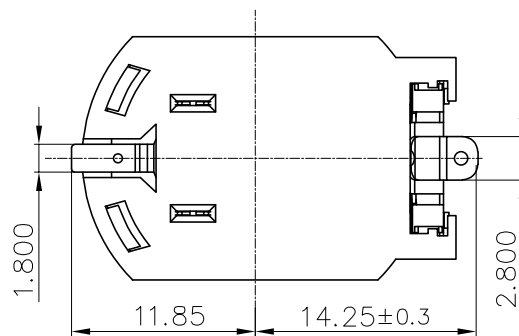

ORDERING INFORMATION

**BS-08-B2AA020**

电池座系列

BS-08系列

SMT 180° TYPE

- A-Au1U"
- J-Ni100U""~120U"
- K-Sn100U""~120U"
- L-Ni50U""- Sn80U"

- MATERIAL:
- 1A-PBT BLACK
  - 1B-PA66 BLACK
  - 2A-PPA BROWN
  - 2B-PPA BLACK
  - 3A-PPS BROWN
  - 3B-PPS BLACK
  - 4A-LCP WHITE
  - 4B-LCP BLACK

工程部

2021-06-09

LQ. HUANG

UNLESS OTHERWISE SPECIFIED TOLERANCES		<b>MYOUNG 美用</b> <a href="http://www.meiyangdz.com">www.meiyangdz.com</a>	
DECIMALS: X :±0.30 X.X :±0.25 X.XX :±0.20 X.XXX :±0.10	ANGLES: X :±1° X.X :±0.5°	DSND YangFeng	DATE 2021-06-09
WEIGHT: 0.92g		CHKD ZhouRuicai	DATE 2021-06-09
SHEET 1 OF 1		APVD XueShunyong	DATE 2021-06-09
SCALE: 2:1		SIZE: A4	VIEW:
UNIT: mm		REV.: A/0	OBJECT: MY
TITLE: BS-2032-8GCK 0.7 SMT		PART NO.: BS-08-B2AA020	
DRAW NO.:MY-CP-0070			

NO.	PART NAME	Q'TY	MATERIAL	PLATING & COLOR
3	TERMINAL(-)	1	PHOSPHOR BRONZE, T=0.20mm	Gold Plating and Ni Under-Plating
2	TERMINAL(+)	1	PHOSPHOR BRONZE, T=0.25mm	Gold Plating and Ni Under-Plating
1	HOUSING	1	PPA	BROWN